



Tony Kennon, Mayor
Jack Robertson, Council
Ginger Harrelson, Council
Jerry Johnson, Council
Jeff Silvers, Council
Robert Stuart II, Council

Ford Handley, City Administrator
Renee Eberly, City Clerk
Jamie Logan, City Attorney

REGULAR CITY COUNCIL MEETING AGENDA

- I. **Call to Order**
- II. **Invocation**
- III. **Pledge of Allegiance**
- IV. **Roll Call**
- V. **Consideration of Agenda**
- VI. **Consideration of Previous Minutes**
 - 1. Work Session 11/17/2025
 - 2. Regular Council Meeting 11/18/2025
 - 3. Committee of the Whole 11/18/2025
 - 4. Special-Called Council Meeting 11/21/2025
- VII. **Reports of Officers/Committees**
 - 1. Finance Director's Report
- VIII. **Auditing of Accounts**
 - 1. Vendor Checks
- IX. **Presentation(s)**
- X. **Recognitions**
- XI. **Unfinished Business**
 - Miscellaneous**
 - Resolutions**

1. Resolution approving the Fiscal Year 2026 Budget for the City of Orange Beach, including the transfer of special revenue funds to general fund for special revenue fund projects.

Ordinances

XII. New Business

Miscellaneous

Resolutions

1. Resolution authorizing the city to host community events for the benefit of citizens and visitors of the City of Orange Beach during 2026.
2. Resolution authorizing the execution of a performance contract with Anne Gajda for golf instruction services.
3. Resolution authorizing the execution of a performance contract with Joan Hill for water aerobics instruction at the Aquatics Center.
4. Resolution to update the list of volunteer firefighters and reserve police officers covered under workers' compensation insurance.
5. Resolution authorizing the execution of retainer agreements for outside counsel for the City of Orange Beach for 2026.
6. Resolution appointing members and reappointing existing members to the Legislative Review Committee.
7. Resolution authorizing the City of Orange Beach, Alabama, to levy taxes within its police jurisdiction for the year 2026.
8. Resolution authorizing execution of a professional services agreement with Chris Litton for various special services.
9. Resolution extending the entertainment district at SanRoc Cay Marina / Perdido Beach Resort.
10. Resolution extending the entertainment district at The Wharf.
11. Resolution authorizing the execution of a professional services agreement with McCollough Architecture, Inc., for architectural services.
12. Resolution authorizing execution of a performance contract with Baldwin County Economic Development Alliance, Inc.
13. Resolution appropriating funds to the Gulf Shores Airport Authority in an amount not to exceed \$75,000 for FY2026.
14. Resolution authorizing execution of a professional services agreement with Socialize Your Bizness, Inc., for social media consulting and marketing services.

15. Resolution authorizing execution of a professional services agreement with Bob Riley and Associates, LLC, for lobbying services.
16. Resolution authorizing execution of a professional services agreement with Van Scoyoc Associates for consulting services.
17. Resolution authorizing execution of a professional services agreement with Adams and Reese, LLP, for federal and state governmental relations and consulting services.
18. Resolution authorizing the purchase of Furniture for the Municipal Court through the BuyBoard Purchasing Cooperative from MityLite Inc. in the amount of \$32,847.64.

Public Hearings

1. Public hearing for an ordinance amending Ordinance No. 172, the Zoning Ordinance, Case No. 0903-PUD-25, AC Hotel Orange Beach PUD.

Ordinances

1. First Reading - Ordinance amending Ordinance No. 172, the Zoning Ordinance, Case No. 0903-PUD-25, AC Hotel Orange Beach PUD.
2. First Reading - Ordinance adopting the Baldwin County Emergency Communications District GIS/Addressing Office street name standards within the City of Orange Beach, Alabama.
3. First Reading - Ordinance amending and restating Chapter 42, Article II, Division 2, Section 42-41 of the Code of Ordinances for the City of Orange Beach, Alabama, to update technical codes for land development.
4. First Reading - Ordinance amending Chapter 70, Article II, Section 70-22 of the Code of Ordinances for the City of Orange Beach, Alabama, to reduce the speed limit from 45 mph to 35 mph on the portion of State Highway 182 from Milepost 11.55 to Milepost 13.13.

XIII. Public Comments

XIV. Adjourn

**MINUTES OF
ORANGE BEACH CITY COUNCIL
WORK SESSION
NOVEMBER 17, 2025 – 1:00 P.M.
CITY HALL – SOUTH CONFERENCE ROOM**

The Orange Beach City Council met on November 17, 2025, at 1:06 P.M. with Mayor Tony Kennon presiding.

The following members were present:

Councilmember Jeff Silvers
Councilmember Jerry Johnson
Councilmember Robert Stuart
Councilmember Jack Robertson
Councilmember Ginger Harrelson
Mayor Tony Kennon

The following members were absent:

None

The following items were discussed:

1. Review of City Council and Committee of the Whole meeting agendas for November 18, 2025.
2. Proposed Fiscal Year 2026 budget and capital requests.
3. Employee healthcare plan.
4. Stop loss insurance.
5. Salary study update.
6. Donation requests.
7. Amicus brief request.
8. Litigation update.

There being no further business, the meeting adjourned.

Time: 4:59 P.M.

APPROVED this 16th day of December, 2025.

Renee Eberly
City Clerk

**MINUTES OF
REGULAR COUNCIL MEETING
ORANGE BEACH CITY COUNCIL
NOVEMBER 18, 2025 – 5:00 P.M.
CITY HALL – COUNCIL CHAMBERS**

- I. CALL TO ORDER** Mayor Kennon called the meeting to order at 4:58 P.M.
- II. INVOCATION** Pastor Brandon Moore, Orange Beach Community Church
- III. PLEDGE OF ALLEGIANCE**
- IV. ADMINISTRATION OF OATH TO COUNCILMEMBER SILVERS**

Pamela Davis, Court Director, administered the oath of office for Councilmember Silvers.

V. ROLL CALL

Present: Councilmember Jeff Silvers
Councilmember Jack Robertson
Councilmember Ginger Harrelson
Councilmember Robert Stuart
Councilmember Jerry Johnson
Mayor Tony Kennon

Absent: None

VI. CONSIDERATION OF AGENDA

Motion made (Johnson/Silvers) to approve the agenda as written. Vote unanimous in favor.

VII. CONSIDERATION OF PREVIOUS MINUTES

Solid Waste Authority Meeting	10/21/2025
Regular Council Meeting	10/21/2025
Committee of the Whole	10/21/2025

The reading was waived and minutes were approved as written.

VIII. REPORTS OF OFFICERS/COMMITTEES

- 1. City Administrator – Ford Handley No report.
- 2. Director, Public Works – Tim Tucker No report.
- 3. Director, Community Development – Adam Roberson No report.
- 4. Chief, Police Department – Trent Johnson No report.
- 5. Chief, Fire Department – Jeff Smith No report.
- 6. City Clerk – Renee Eberly No report.
- 7. Director, Finance – Ford Handley No report.
- 8. Parks & Recreation – Nicole Ard No report.
- 9. Director, Utilities – Rob Stalcup No report.
- 10. Director, Coastal Resources – Phillip West No report.
- 11. Librarian, Public Library – Meagan Bing No report.
- 12. Director, Municipal Court – Pam Davis No report.
- 13. Director, Expect Excellence – Ford Handley No report.

14. Mayor/Council

Councilmember Harrelson introduced Jessica Ware and Niki Whitaker who spoke on behalf of the Baldwin County Child Advocacy Center. They invited everyone to attend the “Starlit Soiree” annual fundraiser being held at the Coastal Arts Center on December 4, 2025.

IX. AUDITING OF ACCOUNTS

Motion made (Harrelson/Stuart) to certify that cash requirements with no related interests are within budget and appropriate for payment. Vote revealed: Silvers, aye; Robertson, aye; Harrelson, aye; Stuart, aye; Johnson, aye; Kennone, aye. **Motion passed. (6-0).**

Motion made (Harrelson/Robertson) to certify that cash requirements with related interests in Swift Supply are within budget and appropriate for payment. Vote revealed: Silvers, abstain; Robertson, aye; Harrelson, aye; Stuart, aye; Johnson, aye; Kennon, aye. **Motion passed. (5-0-1).**

X. PRESENTATIONS

XI. RECOGNITIONS

XII. UNFINISHED BUSINESS

XIII. NEW BUSINESS

Miscellaneous

1. Approval of a Special Events Retail Liquor License Application by Bottles Up Mobile, Inc, for the "Baldwin EMC Christmas Party" event to be held December 6, 2025, at the Orange Beach Event Center, 4671 Wharf Parkway West. **Motion made (Robertson/Harrelson) to approve the liquor license.** Vote unanimous in favor. **Motion passed.**
2. Approval to change the City's Expect Excellence Performing Arts program's spring 2026 theater production from "Guys and Dolls" to "Disney's Frozen The Broadway Musical", and to apply the change to previously approved contracts. **Motion made (Silvers/Stuart) to approve the change.** Vote unanimous in favor. **Motion passed.**
3. Approval to construct a new multipurpose facility on the Police Department campus in an amount not to exceed \$120,000. **Motion made (Johnson/Robertson) to approve the project budget.** Vote unanimous in favor. **Motion passed.**

Resolutions

1. Resolution reappointing Jamie Logan as the City Attorney for the City of Orange Beach, Alabama. **Motion made (Silvers/Robertson) to adopt the resolution.** Vote unanimous in favor. **Motion passed.**
2. Resolution reappointing Renee Eberly as the City Clerk for the City of Orange Beach, Alabama. **Motion made (Stuart/Robertson) to adopt the resolution.** Vote unanimous in favor. **Motion passed.**
3. Resolution reappointing Bedford Handley as the City Treasurer for the City of Orange Beach, Alabama. **Motion made (Silvers/Stuart) to adopt the resolution.** Vote unanimous in favor. **Motion passed.**
4. Resolution reappointing Jeffrey F. Smith as the Fire Chief for the City of Orange Beach, Alabama. **Motion made (Harrelson/Silvers) to adopt the resolution.** Vote unanimous in favor. **Motion passed.**
5. Resolution appointing David Trent Johnson as the Interim Police Chief for the City of Orange Beach, Alabama. **Motion made (Johnson/Stuart) to adopt the resolution.** Vote unanimous in favor. **Motion passed.**

6. Resolution designating depositories and authorized signatures on bank depositories. **Motion made (Silvers/Robertson) to adopt the resolution.** Vote unanimous in favor. **Motion passed.**
7. Resolution amending the fee schedule for the Orange Beach Shooting Complex. **Motion made (Stuart/Harrelson) to adopt the resolution.** Vote unanimous in favor. **Motion passed.**
8. Resolution authorizing execution of a task order with GeoCon Engineering & Materials Testing, Inc., to provide construction materials testing services for the new Fire Training Facility in an amount not to exceed \$20,000. **Motion made (Silvers/Robertson) to adopt the resolution.** Vote unanimous in favor. **Motion passed.**
9. Resolution authorizing execution of a task order with GeoCon Engineering & Materials Testing, Inc., to provide geotechnical exploration and engineering services for a new Police Multipurpose Facility in an amount not to exceed \$3,000. **Motion made (Robertson/Harrelson) to adopt the resolution.** Vote unanimous in favor. **Motion passed.**
10. Resolution authorizing an updated appraisal of the Event Center by The Appraisal & Consultant Group, Inc., in an amount not to exceed \$10,000. **Motion made (Stuart/Robertson) to adopt the resolution.** Vote unanimous in favor. **Motion passed.**
11. Resolution authorizing execution of a professional services agreement with Gerald Mills for theatrical performance direction for "Disney's Frozen The Broadway Musical". **Motion made (Harrelson/Robertson) to adopt the resolution.** Vote unanimous in favor. **Motion passed.**
12. Resolution awarding the bid for Audio Visual Equipment to Big Blue LLC, dba Blue AV, in the amount of \$67,691.25. **Motion made (Harrelson/Silvers) to adopt the resolution.** Vote unanimous in favor. **Motion passed.**

Public Hearings

1. Public hearing for an ordinance amending Ordinance No. 172, the Zoning Ordinance, Case No. 0905-PUDA-25, Jones Duplexes PUD Modification – Turquoise Village.

Griffin Powell, City Planner, presented the request by Overstreet & Associates Consulting Engineers, on behalf of Rodney Jones, requests approval of a major modification of the Jones Duplexes PUD (Planned Unit Development) Master Plan to rezone 7.9 acres from RS-1 (Single-Family Residential) to PUD (Planned Unit Development) and to amend the development into a beachfront residential development containing 18 single-family houses and 10 duplexes for 38 total dwelling units. The property is located at 26480, 26504, 26536, and 26558 Perdido Beach Boulevard.

Council asked questions to clarify parking, setbacks, and traffic requirements. Griffin explained that changes recommended by the Planning Commission have resulting in an amended parking plan, and that traffic requirements are set by ALDOT (Alabama Department of Transportation).

Rodney Jones, developer, spoke in more detail about the changes made to the request to address the concerns raised by Planning Commission. Changes included eliminating a house to expand spaces between houses and to widen interior streets from 20' to 25'. Councilmember Stuart expressed his gratitude for the developer's cooperation.

There being no additional comments, the public hearing adjourned.

Ordinances

1. First Reading – Ordinance amending Ordinance No. 172, the Zoning Ordinance, Case No. 0905-PUDA-25, Jones Duplexes PUD Modification – Turquoise Village. **Motion made (Silvers/Harrelson) for unanimous consent to suspend the rules to allow for immediate**

- consideration of this ordinance.** Roll call vote revealed: Silvers, aye; Robertson, aye; Harrelson, aye; Stuart, aye; Johnson, aye; Kennon, aye. **Motion passed. (6-0). Motion made (Silvers/Stuart) to adopt the ordinance.** Roll call vote revealed: Silvers, aye; Robertson, aye; Harrelson, aye; Stuart, aye; Johnson, aye; Kennon, aye. **Motion passed. (6-0).**
2. First Reading – Ordinance extending the temporary moratorium on consideration of certain multi-family residential projects and subdivision applications established by Ordinance No. 2025-1504. **Motion made (Harrelson/Robertson) for unanimous consent to suspend the rules to allow for immediate consideration of this ordinance.** Roll call vote revealed: Silvers, aye; Robertson, aye; Harrelson, aye; Stuart, aye; Johnson, aye; Kennon, aye. **Motion passed. (6-0). Motion made (Silvers/Harrelson) to adopt the ordinance.** Roll call vote revealed: Silvers, aye; Robertson, aye; Harrelson, aye; Stuart, aye; Johnson, aye; Kennon, aye. **Motion passed. (6-0).**
 3. First Reading – Ordinance extending the temporary moratorium on development of or within 15 feet of wetlands and utilization of wetland acreage in density calculations established by Ordinance No. 2025-1513. **Motion made (Stuart/Harrelson) for unanimous consent to suspend the rules to allow for immediate consideration of this ordinance.** Roll call vote revealed: Silvers, aye; Robertson, aye; Harrelson, aye; Stuart, aye; Johnson, aye; Kennon, aye. **Motion passed. (6-0). Motion made (Silvers/Johnson) to adopt the ordinance.** Mayor Kennon stated that it is Council's intent to move faster on resolving issues with development near wetlands to allow residential building to resume. Roll call vote revealed: Silvers, aye; Robertson, aye; Harrelson, aye; Stuart, aye; Johnson, aye; Kennon, aye. **Motion passed. (6-0).**

XIII. PUBLIC COMMENTS

None

XIV. ADJOURN

There being no further business to come before the council, motion made (Robertson/Stuart) to adjourn. Vote unanimous in favor.

Time: 5:27 P.M.

APPROVED this the 16th day of December, 2025.

Renee Eberly
City Clerk

**MINUTES OF
COMMITTEE OF THE WHOLE MEETING
ORANGE BEACH CITY COUNCIL
NOVEMBER 18, 2025 – 5:27 P.M.
CITY HALL – COUNCIL CHAMBERS**

The Orange Beach City Council met to review potential items for the December 2, 2025, agenda.

The following members were present:

Councilmember Jeff Silvers
Councilmember Jack Robertson
Councilmember Ginger Harrelson
Councilmember Robert Stuart
Councilmember Jerry Johnson
Mayor Tony Kennon

The following members were absent:

None

The following items were discussed:

1. Discuss stop loss insurance.
2. Discuss rescheduling Council and Committee of the Whole Meetings on December 2, 2025, from 5:00 P.M. to 4:00 P.M. to allow for the Christmas Tree Lighting event. Meetings rescheduled to 3:00 P.M. on December 2, 2025.
3. Resolution authorizing the execution of a professional services agreement with Computer Backup, Inc., for technology support and managed services.
4. Resolution authorizing the execution of an interlocal agreement with the Baldwin County Emergency Communication District for E-911 services.
5. Award the bid for construction of the Contorno Park Trails Project, Phase One.
6. Resolution authorizing an additional one-time payment to city employees for future services.
7. Resolution declaring Christmas Pole Decorations owned by the City of Orange Beach as surplus and unneeded and authorizing the Mayor and City Clerk to dispose of such property.
8. Resolution authorizing execution of a task order with Seay, Seay & Litchfield, P.C., to provide professional design services for a new Civic Center in an amount not to exceed \$692,725.86.
9. Resolution appointing Ryan Long and Paul McGhee to the Board of Adjustment.
10. Resolution of a task order with GeoCon Engineering & Materials Testing, Inc., to provide geotechnical exploration and engineering services for a new Pool at the Aquatics Center in an amount not to exceed \$5,200.
11. Resolution authorizing execution of a medical services agreement with Foley Clinic Corp, dba Baldwin Health Medical Group Primary and Urgent Care at Orange Beach.
12. Resolution authorizing execution of a medical services agreement with Coastal 3 Holdings, LLC, dba Southern Rapid Healthcare.
13. Resolution approving the Fiscal Year 2026 Budget for the City of Orange Beach, including the transfer of special revenue funds to general fund for special revenue fund projects.

14. Set a public hearing date for an ordinance amending Ordinance No. 172, the Zoning Ordinance, Case No. 0903-PUD-25, AC Hotel Orange Beach PUD. Public hearing set for December 16, 2025.
15. Ordinance amending Chapter 50, Article XIII of the Code of Ordinances for the City of Orange Beach, Alabama, entitled "Recreational Vehicle Rentals". This item will not move forward for consideration at this time.

Public Comments:

1. Ford Handley, City Administrator/Finance Director, thanked department heads for their work on the Fiscal Year 2026 Budget. He gave a brief overview of ongoing and upcoming capital projects.
2. Ashley Powell, property owner, and Ken Vicens, contractor, requested consideration from Mayor and Council on their residential build that is being affected by the moratorium on wetlands construction. Ms. Powell explained that her family is moving into Orange Beach city limits from Ono Island due to the city school system and tuition concerns, but that the lot she has purchased is affected by the ongoing moratorium. Mr. Vicens suggested shortening the distance on wetlands setbacks. Mayor and Council responded that they plan to move expediently.
3. Lori DeAngelis, resident, stated that the music at Oso at Bear Point has become much too loud, and that the type of music has also become less family-friendly. As a long-time resident of Bear Point, Ms. DeAngelis stated that the music can be heard inside her home until 9 or 10 P.M. at night, and then people hang around after closing. She also had concerns about the large tent that has been erected, chickens being fed outside the restaurant kitchen door, and that the area has become more of a bar atmosphere than a restaurant. Councilmember Stuart thanked Ms. DeAngelis for voicing her concerns. Mayor Kennon shared that the city has meetings planned with the business managers, and that they will be addressing what is noncompliant with city regulations and creating a plan to resolve noise issues. A sound barrier wall has been proposed. Mayor Kennon also stated that the chicken issue may have to be resolved by the community.

Executive Session:

1. Executive session to discuss pending litigation. **Motion made (Harrelson/Johnson) to enter executive session.** The City Attorney advised the Council that a declaration was required by the Open Meetings Act for an Executive Session; therefore, she stated for the record that she was duly qualified and had the personal knowledge to provide the requisite declaration for the stated purposes of the Executive Session authorized by the Act. The Mayor announced that the executive session would last approximately 45 minutes, and that Council would not reconvene after the executive session.

Time in: 6:07 P.M.

Time out: 6:30 P.M.

There being no further business, the meeting adjourned.

Time: 6:30 P.M.

APPROVED this 16th day of December, 2025.

Renee Eberly
City Clerk

**MINUTES OF
SPECIAL-CALLED COUNCIL MEETING
ORANGE BEACH CITY COUNCIL
NOVEMBER 21, 2025 – 11:00 A.M.
CITY HALL – COUNCIL CHAMBERS**

I. CALL TO ORDER Mayor Tony Kennon called the meeting to order at 11:02 A.M.

II. ROLL CALL

Present: Councilmember Jeff Silvers
Councilmember Jack Robertson
Councilmember Ginger Harrelson
Councilmember Robert Stuart
Mayor Tony Kennon

Absent: Councilmember Jerry Johnson

There being a quorum present, the meeting was opened for the transaction of business.

III. CONSIDERATION OF AGENDA: Motion made (Stuart/Harrelson) to approve the agenda as presented. Vote unanimous in favor.

IV. NEW BUSINESS

Resolutions

1. Resolution authorizing settlement in the case of *Wireman, et al., v. The City of Orange Beach.*
Motion made (Harrelson/Robertson) to adopt the resolution. Vote revealed: Silvers, aye; Robertson, aye; Harrelson, aye; Stuart, aye; Kennon, aye. **Passed. (5-0).**

VI. ADJOURN

There being no further business to come before the council, motion made (Silvers/Robertson) to adjourn. Vote unanimous in favor.

Time: 11:03 A.M.

APPROVED this the 16th day of December, 2025.

Renee Eberly
City Clerk

ACCOUNTS PAYABLE CHECK REGISTER

Check Register for 12/4/2025 to 12/17/2025 & Check Numbers 0 to 2147483647

Cash Account 001-000-011

Check Number	Check Date	Vendor Number / Name	Payment Type	EPay	Amount (\$)	
Check Run: 8177						
*****	12/17/2025	3176 BEEBE'S ACTION MASTERS P.C.	Check	No	1,030.00	
	Purchase Order #: 0	Voucher #: 171461	Invoice #: 1000031		350.00	
	Invoice Description:	STN 1 SENTRICON				
	001-175-616	RPR/MAINT PLANT/BLDGS			350.00	
	Purchase Order #: 0	Voucher #: 171462	Invoice #: 1000032		350.00	
	Invoice Description:	STN 2 SENTRICON				
	001-175-616	RPR/MAINT PLANT/BLDGS			350.00	
	Purchase Order #: 0	Voucher #: 171463	Invoice #: 1000696		330.00	
	Invoice Description:	CLAY SHOP SENTRICON				
	430-682-612	PROFESSIONAL FEES			330.00	
Check Run 8177 Check Total					\$1,030.00	
Check Run 8177 Update Only					\$0.00	
Check Run 8177 Total					\$1,030.00	
Check Run: 8195						
*****	12/08/2025	5627 GULF COAST ORGANIC, INC	Check	No	1,626.54	
	Purchase Order #: 0	Voucher #: 171029	Invoice #: K00298/1		776.08	
	Invoice Description:	2 BAGS ARGNTN BAHIA SEED				
	001-410-620	RPR/MAINT GROUNDS			776.08	
	Purchase Order #: 0	Voucher #: 171030	Invoice #: 260 /1		776.08	
	Invoice Description:	2 BAGS ARGNTN BAHIA SEED				
	001-410-620	RPR/MAINT GROUNDS			776.08	
	Purchase Order #: 0	Voucher #: 171031	Invoice #: 281 /1		74.38	
	Invoice Description:	FUNGICIDE				
	001-410-620	RPR/MAINT GROUNDS			74.38	
Check Run 8195 Check Total					\$1,626.54	
Check Run 8195 Update Only					\$0.00	
Check Run 8195 Total					\$1,626.54	
Check Run: 8198						
*	*****	12/17/2025	3060 AARON'S LOCK SERVICE	Check	No	985.00
	Purchase Order #: 0	Voucher #: 175897	Invoice #: 125255		985.00	
	Invoice Description:	CNCSSN TRLR LCKS				
	001-301-516	SUPPLIES/OPERATING			985.00	
*****	12/17/2025	109 ADEM	Check	No	125.00	
	Purchase Order #: 0	Voucher #: 175898	Invoice #: 251203		125.00	
	Invoice Description:	E OSBORNE GR IV				
	403-676-612	PROFESSIONAL FEES			125.00	
*****	12/17/2025	7498 ADVANCE AUTO PARTS	Check	No	3,636.37	
	Purchase Order #: 0	Voucher #: 175542	Invoice #: 3192		72.45	
	Invoice Description:	STK BRK FLD				
	001-210-516	SUPPLIES/OPERATING			72.45	
	Purchase Order #: 0	Voucher #: 175543	Invoice #: 303255		359.00	
	Invoice Description:	STK HYDRCL FLD				

ACCOUNTS PAYABLE CHECK REGISTER

Check Register for 12/4/2025 to 12/17/2025 & Check Numbers 0 to 2147483647

Cash Account 001-000-011

Check Number	Check Date	Vendor Number / Name	Payment Type	EPay	Amount (\$)
		001-200-510 GAS/OIL		359.00	
		Purchase Order #: 0 Voucher #: 175544 Invoice #: 3289			194.04
		Invoice Description: STK TRNSMSSN FLD			
		404-677-510 GAS/OIL		194.04	
		Purchase Order #: 0 Voucher #: 175545 Invoice #: 8882			215.40
		Invoice Description: STK HYDRLC FLD			
		001-200-510 GAS/OIL		215.40	
		Purchase Order #: 0 Voucher #: 175546 Invoice #: 8967			168.83
		Invoice Description: #299 BATTERY			
		001-100-622 RPR/MAINT VEHICLES		168.83	
		Purchase Order #: 0 Voucher #: 175547 Invoice #: 8969			161.20
		Invoice Description: #294 SENSORS			
		001-100-622 RPR/MAINT VEHICLES		161.20	
		Purchase Order #: 0 Voucher #: 175548 Invoice #: 9056			622.90
		Invoice Description: #23-205 BRK RTRS/ PADS			
		001-100-622 RPR/MAINT VEHICLES		622.90	
		Purchase Order #: 0 Voucher #: 175549 Invoice #: 9294			28.50
		Invoice Description: STK ARMR ALL/ GLSS CLNR			
		001-210-516 SUPPLIES/OPERATING		28.50	
		Purchase Order #: 0 Voucher #: 175550 Invoice #: 9563			28.92
		Invoice Description: STK DEF FLD			
		404-677-510 GAS/OIL		28.92	
		Purchase Order #: 0 Voucher #: 175551 Invoice #: 9566			415.41
		Invoice Description: STK TRNSMSSN FLD/ BRK CLNR/ WPR FLD			
		001-210-516 SUPPLIES/OPERATING		415.41	
		Purchase Order #: 0 Voucher #: 175686 Invoice #: 4768			40.30
		Invoice Description: #172 TR PRSSR SNSR			
		001-020-622 RPR/MAINT VEHICLES		40.30	
		Purchase Order #: 0 Voucher #: 175687 Invoice #: 9510			168.83
		Invoice Description: #274 BATTERY			
		001-100-622 RPR/MAINT VEHICLES		168.83	
		Purchase Order #: 0 Voucher #: 175899 Invoice #: 3436			40.30
		Invoice Description: #296 SNSR			
		001-100-622 RPR/MAINT VEHICLES		40.30	
		Purchase Order #: 0 Voucher #: 175900 Invoice #: 3517			161.20
		Invoice Description: #710 SNSRS			
		001-200-622 RPR/MAINT VEHICLES		161.20	
		Purchase Order #: 0 Voucher #: 175901 Invoice #: 3533			168.83
		Invoice Description: #0142 BATTERY			
		001-210-618 RPR/MAINT EQUIPMENT		168.83	
		Purchase Order #: 0 Voucher #: 175902 Invoice #: 3642			168.83
		Invoice Description: #210 BATTERY			
		001-100-622 RPR/MAINT VEHICLES		168.83	
		Purchase Order #: 0 Voucher #: 175903 Invoice #: 3643			411.03
		Invoice Description: #205 BRK RTRS/ PADS			
		001-100-622 RPR/MAINT VEHICLES		411.03	
		Purchase Order #: 0 Voucher #: 175904 Invoice #: 9188			45.55
		Invoice Description: #786 BATTERY			

ACCOUNTS PAYABLE CHECK REGISTER

Check Register for 12/4/2025 to 12/17/2025 & Check Numbers 0 to 2147483647

Cash Account 001-000-011

Check Number	Check Date	Vendor Number / Name	Payment Type	EPay	Amount (\$)
		001-210-618 RPR/MAINT EQUIPMENT			45.55
		Purchase Order #: 0 Voucher #: 175905 Invoice #: 9420			15.99
		Invoice Description: STK WR TUBE BRSH			
		001-200-516 SUPPLIES/OPERATING			15.99
		Purchase Order #: 0 Voucher #: 175906 Invoice #: 903548			148.86
		Invoice Description: STK OIL/ DEF FLD			
		404-677-510 GAS/OIL			148.86
*****	12/17/2025	6133 ADVANCED CLINICAL SERVICES LLC	Check	No	1,550.00
		Purchase Order #: 0 Voucher #: 175552 Invoice #: 8400			1,550.00
		Invoice Description: Q4 DRG TSTNG			
		001-001-612 PROFESSIONAL FEES			1,550.00
*****	12/17/2025	7001 AGROMAX, LLC	Check	No	6,512.92
		Purchase Order #: 0 Voucher #: 175553 Invoice #: 24522			2,490.84
		Invoice Description: FRTLIZR/ RYE SEED			
		001-210-620 RPR/MAINT GROUNDS			2,490.84
		Purchase Order #: 0 Voucher #: 175554 Invoice #: 24523			1,560.00
		Invoice Description: HRBICD/ FNGICD/ GYPSM			
		001-210-620 RPR/MAINT GROUNDS			1,560.00
		Purchase Order #: 0 Voucher #: 175907 Invoice #: 24539			2,462.08
		Invoice Description: 32 BAGS RYE SEED			
		001-210-620 RPR/MAINT GROUNDS			2,462.08
*****	12/17/2025	3115 ALABAMA 811	Check	No	880.80
		Purchase Order #: 0 Voucher #: 175908 Invoice #: 1125031			880.80
		Invoice Description: MONTHLY PARTICIPATION			
		403-676-612 PROFESSIONAL FEES			880.80
*****	12/17/2025	8673 AL ASSOCIATION OF EMERGENCY MANAGERS	Check	No	50.00
		Purchase Order #: 0 Voucher #: 175909 Invoice #: 300001199			50.00
		Invoice Description: '26 AAEM DUES			
		001-410-608 DUES/MEMBERSHIP/SUBSCRIPT			50.00
*****	12/17/2025	132 AL CRIME VICTIMS COMPENSATION COMMISSION	Check	No	326.00
		Purchase Order #: 0 Voucher #: 175842 Invoice #: 251201			326.00
		Invoice Description: NOV 2025			
		001-000-128 DUE COST FOR OTH AGENCIES			326.00
*****	12/17/2025	130 AL DEPT OF REV/COLL SERV DIV	Check	No	367.50
		Purchase Order #: 0 Voucher #: 175910 Invoice #: 112825-BARLOW			150.00
		Invoice Description: L0503762960			
		001-000-104 GARNISHMENT/SAVINGS			150.00
		Purchase Order #: 0 Voucher #: 175911 Invoice #: 112825-ODOM			217.50
		Invoice Description: L1179838480			
		001-000-104 GARNISHMENT/SAVINGS			217.50
*****	12/17/2025	6550 AL INTERLOCK INDIGENT FUND	Check	No	54.00
		Purchase Order #: 0 Voucher #: 175843 Invoice #: 251201			54.00
		Invoice Description: NOV 2025			
		001-000-128 DUE COST FOR OTH AGENCIES			54.00

ACCOUNTS PAYABLE CHECK REGISTER

Check Register for 12/4/2025 to 12/17/2025 & Check Numbers 0 to 2147483647

Cash Account 001-000-011

Check Number	Check Date	Vendor Number / Name	Payment Type	EPay	Amount (\$)
****	12/17/2025	3436 AL LAW ENFORCEMENT AGENCY	Check	No	1,800.00
		Purchase Order #: 0 Voucher #: 175912 Invoice #: 26000000010			1,800.00
		Invoice Description: NOV 2025 RENT			
		001-100-614 RENTALS			1,800.00
****	12/17/2025	248 ALLEGION ACCESS TECHNOLOGIES LLC	Check	No	1,964.58
		Purchase Order #: 0 Voucher #: 175841 Invoice #: 90080301			1,964.58
		Invoice Description: HANDICAP OPENER RPR			
		001-325-616 RPR/MAINT PLANT/BLDGS			1,964.58
****	12/17/2025	8262 ALLIED MEDICAL WASTE	Check	No	312.79
		Purchase Order #: 0 Voucher #: 175913 Invoice #: 370730A			312.79
		Invoice Description: NOV 2025 MED WASTE PKUP			
		001-175-612 PROFESSIONAL FEES			312.79
****	12/17/2025	144 AL PEACE OFFICERS' ANNUITY & BENEFIT FD	Check	No	398.00
		Purchase Order #: 0 Voucher #: 175844 Invoice #: 251201			398.00
		Invoice Description: NOV 2025			
		001-000-128 DUE COST FOR OTH AGENCIES			398.00
****	12/17/2025	7828 AMAZON CAPITAL SERVICES, INC	Check	No	15,375.93
		Purchase Order #: 0 Voucher #: 175555 Invoice #: 137G-HND1-1W1F			280.86
		Invoice Description: STNLSS STRAPPING			
		001-200-516 SUPPLIES/OPERATING			280.86
		Purchase Order #: 0 Voucher #: 175556 Invoice #: 14XL-PWDW-6WPD			291.18
		Invoice Description: LED RP LTS/ GRLND/ CHN/ ZIP TIES			
		001-200-516 SUPPLIES/OPERATING			291.18
		Purchase Order #: 0 Voucher #: 175557 Invoice #: 171R-MV1W-1RCX			110.97
		Invoice Description: #767 LATCH SETS			
		001-200-618 RPR/MAINT EQUIPMENT			110.97
		Purchase Order #: 0 Voucher #: 175558 Invoice #: 19CX-HXND-CQG4			303.92
		Invoice Description: #828 TIRES			
		404-677-618 RPR/MAINT EQUIPMENT			303.92
		Purchase Order #: 0 Voucher #: 175559 Invoice #: 1C9D-NQ37-6N1X			127.41
		Invoice Description: HNGRS/ DIVIDERS			
		001-100-540 UNIFORMS			127.41
		Purchase Order #: 0 Voucher #: 175560 Invoice #: 1CGF-CCH9-MW6L			18.98
		Invoice Description: USB C HUB			
		001-030-516 SUPPLIES/OPERATING			18.98
		Purchase Order #: 0 Voucher #: 175561 Invoice #: 1FJR-HFQN-LQTD			29.94
		Invoice Description: BTTLD WTR			
		430-682-659 RESALE INV/CENTER			29.94
		Purchase Order #: 0 Voucher #: 175562 Invoice #: 1FK7-FDKF-63YW			49.98
		Invoice Description: CMAS GRLND			
		001-200-516 SUPPLIES/OPERATING			49.98
		Purchase Order #: 0 Voucher #: 175563 Invoice #: 1HGQ-G9P9-C7LT			27.99
		Invoice Description: LED ROPE LIGHTS			
		001-200-516 SUPPLIES/OPERATING			27.99
		Purchase Order #: 0 Voucher #: 175564 Invoice #: 1L91-PMTX-MLLP			57.98
		Invoice Description: ORNMNT DSPLY STNDS			

ACCOUNTS PAYABLE CHECK REGISTER

Check Register for 12/4/2025 to 12/17/2025 & Check Numbers 0 to 2147483647

Cash Account 001-000-011

Check Number	Check Date	Vendor Number / Name	Payment Type	EPay	Amount (\$)
		430-682-659 RESALE INV/CENTER		57.98	
		<i>Purchase Order #:</i> 0 <i>Voucher #:</i> 175565 <i>Invoice #:</i> 1T3Y-Q1VJ-1TT6			413.55
		<i>Invoice Description:</i> TIE DWNS/ CAR FRSHNRS			
		001-210-516 SUPPLIES/OPERATING		413.55	
		<i>Purchase Order #:</i> 0 <i>Voucher #:</i> 175566 <i>Invoice #:</i> 1YT9-FWF7-CQ7D			213.74
		<i>Invoice Description:</i> FLOOR WAX			
		001-200-513 SUPPLIES/JANITORIAL		213.74	
		<i>Purchase Order #:</i> 0 <i>Voucher #:</i> 175688 <i>Invoice #:</i> 13Y9-KQ31-DFCL			179.99
		<i>Invoice Description:</i> OFC CHR			
		001-300-516 SUPPLIES/OPERATING		179.99	
		<i>Purchase Order #:</i> 0 <i>Voucher #:</i> 175689 <i>Invoice #:</i> 144T-DYYD-WHY1			18.29
		<i>Invoice Description:</i> P-TWL HLDR/ CALC TP			
		001-325-516 SUPPLIES/OPERATING		18.29	
		<i>Purchase Order #:</i> 0 <i>Voucher #:</i> 175690 <i>Invoice #:</i> 14Y9-9YFD-GMLY			99.17
		<i>Invoice Description:</i> TBLCLTHS/ BLLN ARCH/ BLLNS			
		001-300-516 SUPPLIES/OPERATING		99.17	
		<i>Purchase Order #:</i> 0 <i>Voucher #:</i> 175691 <i>Invoice #:</i> 16MQ-XDPD-DHRM			266.46
		<i>Invoice Description:</i> BOOTS/ SHORTS			
		001-410-540 UNIFORMS		266.46	
		<i>Purchase Order #:</i> 0 <i>Voucher #:</i> 175692 <i>Invoice #:</i> 16P3-NP9M-94GC			90.93
		<i>Invoice Description:</i> WNTR GLVS			
		001-303-516 SUPPLIES/OPERATING		90.93	
		<i>Purchase Order #:</i> 0 <i>Voucher #:</i> 175693 <i>Invoice #:</i> 171R-MV1W-NP36			284.99
		<i>Invoice Description:</i> LSR ENGRVR TUBE			
		001-410-507 EQUIPMENT/SMALL		284.99	
		<i>Purchase Order #:</i> 0 <i>Voucher #:</i> 175694 <i>Invoice #:</i> 19NL-HCNY-4374			322.44
		<i>Invoice Description:</i> ACCENT CHR			
		001-300-516 SUPPLIES/OPERATING		322.44	
		<i>Purchase Order #:</i> 0 <i>Voucher #:</i> 175695 <i>Invoice #:</i> 1CNW-TTPT-3RVJ			113.91
		<i>Invoice Description:</i> SPC HEATERS			
		001-010-616 RPR/MAINT PLANT/BLDGS		113.91	
		<i>Purchase Order #:</i> 0 <i>Voucher #:</i> 175696 <i>Invoice #:</i> 1D3Q-6TMT-FW3C			286.17
		<i>Invoice Description:</i> CHNSW BTRY KIT			
		001-614-743 NRDA MARINE DEBRIS GRANT		286.17	
		<i>Purchase Order #:</i> 0 <i>Voucher #:</i> 175697 <i>Invoice #:</i> 1D3Q-6TMT-HCMM			89.98
		<i>Invoice Description:</i> MAIL DROP BOX			
		001-300-516 SUPPLIES/OPERATING		89.98	
		<i>Purchase Order #:</i> 0 <i>Voucher #:</i> 175698 <i>Invoice #:</i> 1DK6-Y93X-44MX			50.39
		<i>Invoice Description:</i> DESK RISER			
		001-410-650 AUDUBON		50.39	
		<i>Purchase Order #:</i> 0 <i>Voucher #:</i> 175699 <i>Invoice #:</i> 1FNT-PXGJ-PCN7			-9.88
		<i>Invoice Description:</i> CRDT- WTR THRMOMTR			
		001-410-516 SUPPLIES/OPERATING		-9.88	
		<i>Purchase Order #:</i> 0 <i>Voucher #:</i> 175700 <i>Invoice #:</i> 1GC1-N1GR-94YW			196.59
		<i>Invoice Description:</i> STNCHN PSTS/ STRNG LT PLS/ CRPT RNNR			
		001-300-516 SUPPLIES/OPERATING		196.59	
		<i>Purchase Order #:</i> 0 <i>Voucher #:</i> 175701 <i>Invoice #:</i> 1GQ9-6RNP-7X1R			26.97
		<i>Invoice Description:</i> LAMINATOR			

ACCOUNTS PAYABLE CHECK REGISTER

Check Register for 12/4/2025 to 12/17/2025 & Check Numbers 0 to 2147483647

Cash Account 001-000-011

Check Number	Check Date	Vendor Number / Name	Payment Type	EPay	Amount (\$)
		001-325-516 SUPPLIES/OPERATING		26.97	
		<i>Purchase Order #:</i> 0 <i>Voucher #:</i> 175702 <i>Invoice #:</i> 1J9J-WPRT-CXMC			50.11
		<i>Invoice Description:</i> MGNTS/ CRFT ADHSV/ TAPE			
		430-682-516 SUPPLIES/OPERATING		50.11	
		<i>Purchase Order #:</i> 0 <i>Voucher #:</i> 175703 <i>Invoice #:</i> 1KK3-LTFV-CVNG			89.99
		<i>Invoice Description:</i> ROASTER OVEN			
		001-300-516 SUPPLIES/OPERATING		89.99	
		<i>Purchase Order #:</i> 0 <i>Voucher #:</i> 175704 <i>Invoice #:</i> 1KM9-X4PX-DK9F			267.14
		<i>Invoice Description:</i> SHORTS			
		001-410-540 UNIFORMS		267.14	
		<i>Purchase Order #:</i> 0 <i>Voucher #:</i> 175705 <i>Invoice #:</i> 1L66-G3X9-VT1Q			19.98
		<i>Invoice Description:</i> CMAS ORNMNTS			
		001-302-516 SUPPLIES/OPERATING		19.98	
		<i>Purchase Order #:</i> 0 <i>Voucher #:</i> 175706 <i>Invoice #:</i> 1LWD-QCCF-C7WG			329.98
		<i>Invoice Description:</i> BOOTS			
		001-100-540 UNIFORMS		329.98	
		<i>Purchase Order #:</i> 0 <i>Voucher #:</i> 175707 <i>Invoice #:</i> 1LWD-QCCF-JV7R			188.33
		<i>Invoice Description:</i> WLL ART/ FL SRTR/ MNTR RSR/ BZ CRD HLDR			
		001-300-516 SUPPLIES/OPERATING		188.33	
		<i>Purchase Order #:</i> 0 <i>Voucher #:</i> 175708 <i>Invoice #:</i> 1M11-H1YC-H9N3			22.94
		<i>Invoice Description:</i> CNNMN STKS			
		001-300-516 SUPPLIES/OPERATING		22.94	
		<i>Purchase Order #:</i> 0 <i>Voucher #:</i> 175709 <i>Invoice #:</i> 1NHT-1NL7-NF19			126.81
		<i>Invoice Description:</i> iPHN CASES/ SCRN PRTCTR			
		001-100-507 EQUIPMENT/SMALL		126.81	
		<i>Purchase Order #:</i> 0 <i>Voucher #:</i> 175710 <i>Invoice #:</i> 1Q1W-XGMY-T1TR			164.80
		<i>Invoice Description:</i> OATS/ SLCN TAPE			
		001-410-516 SUPPLIES/OPERATING		164.80	
		<i>Purchase Order #:</i> 0 <i>Voucher #:</i> 175711 <i>Invoice #:</i> 1QQD-WRHN-639V			27.58
		<i>Invoice Description:</i> SHIRTS/ BLLN BAGS			
		001-300-516 SUPPLIES/OPERATING		27.58	
		<i>Purchase Order #:</i> 0 <i>Voucher #:</i> 175712 <i>Invoice #:</i> 1RJR-KQJP-JGY1			399.95
		<i>Invoice Description:</i> CNPY TENT			
		001-301-516 SUPPLIES/OPERATING		399.95	
		<i>Purchase Order #:</i> 0 <i>Voucher #:</i> 175713 <i>Invoice #:</i> 1TNC-3R64-HKGH			21.42
		<i>Invoice Description:</i> SCTCHGRD SPRY/ DSTR RFLLS			
		001-300-516 SUPPLIES/OPERATING		21.42	
		<i>Purchase Order #:</i> 0 <i>Voucher #:</i> 175714 <i>Invoice #:</i> 1TNC-3R64-LR1N			125.13
		<i>Invoice Description:</i> FOOD CNTNRS/ CUPS/ NPKN HLDR			
		001-300-516 SUPPLIES/OPERATING		125.13	
		<i>Purchase Order #:</i> 0 <i>Voucher #:</i> 175715 <i>Invoice #:</i> 1V96-VPCG-6LKL			29.53
		<i>Invoice Description:</i> CMAS DOORMAT			
		001-300-516 SUPPLIES/OPERATING		29.53	
		<i>Purchase Order #:</i> 0 <i>Voucher #:</i> 175716 <i>Invoice #:</i> 1VHR-9WMY-1LLJ			40.90
		<i>Invoice Description:</i> TRSH CAN DLLY BTM			
		001-300-516 SUPPLIES/OPERATING		40.90	
		<i>Purchase Order #:</i> 0 <i>Voucher #:</i> 175717 <i>Invoice #:</i> 1VWT-JDJD-7XDF			31.99
		<i>Invoice Description:</i> #821 STARTER			

ACCOUNTS PAYABLE CHECK REGISTER

Check Register for 12/4/2025 to 12/17/2025 & Check Numbers 0 to 2147483647

Cash Account 001-000-011

Check Number	Check Date	Vendor Number / Name	Payment Type	EPay	Amount (\$)
		001-301-618 RPR/MAINT EQUIPMENT		31.99	
		Purchase Order #: 0 Voucher #: 175718 Invoice #: 1X3C-4LKY-QFK9			13.77
		Invoice Description: CMPTR SPKRS			
		001-410-650 AUDUBON		13.77	
		Purchase Order #: 0 Voucher #: 175719 Invoice #: 1XDG-YXPY-WY6X			9.49
		Invoice Description: WLKR SIDEBAGS			
		001-110-507 EQUIPMENT/SMALL		9.49	
		Purchase Order #: 0 Voucher #: 175720 Invoice #: 1XHD-D36G-7MHY			19.99
		Invoice Description: WRSTLT WLLT			
		001-300-516 SUPPLIES/OPERATING		19.99	
		Purchase Order #: 0 Voucher #: 175721 Invoice #: 1XNP-QVXM-3WRW			254.75
		Invoice Description: DRSSR/ DNG CHR/ PUB TBL			
		001-300-516 SUPPLIES/OPERATING		254.75	
		Purchase Order #: 0 Voucher #: 175722 Invoice #: 1XWJ-DD3M-6MVR			23.98
		Invoice Description: DESK CLNDR			
		001-300-516 SUPPLIES/OPERATING		23.98	
		Purchase Order #: 0 Voucher #: 175922 Invoice #: 11W1-WFVR-7VQ1			184.96
		Invoice Description: SPC HTRS/ AIRTAG			
		001-001-507 EQUIPMENT/SMALL		184.96	
		Purchase Order #: 0 Voucher #: 175925 Invoice #: 13XX-G6FT-1X9K			422.42
		Invoice Description: WTR FNTN FLTR/ CMAS LTS/ GFFR TAPE			
		411-681-516 SUPPLIES/OPERATING		422.42	
		Purchase Order #: 0 Voucher #: 175927 Invoice #: 144T-DYYD-RK7T			19.97
		Invoice Description: GRG WLL SHLF			
		001-410-616 RPR/MAINT PLANT/BLDGS		19.97	
		Purchase Order #: 0 Voucher #: 175930 Invoice #: 144T-DYYD-RK9Q			1,222.90
		Invoice Description: 'VSNS' CSTMS/ GAS MSKS/ FL BXS			
		001-375-636 PRODUCTION COST		967.09	
		001-375-516 SUPPLIES/OPERATING		255.81	
		Purchase Order #: 0 Voucher #: 175931 Invoice #: 14KR-W9C1-YF9X			36.23
		Invoice Description: PRTY SPPLS/ LBLS			
		001-001-516 SUPPLIES/OPERATING		36.23	
		Purchase Order #: 0 Voucher #: 175932 Invoice #: 14TY-4NQG-NPT6			7.99
		Invoice Description: PPR CLP DSPNSR			
		001-300-516 SUPPLIES/OPERATING		7.99	
		Purchase Order #: 0 Voucher #: 175933 Invoice #: 14WW-KMGQ-4MP3			70.17
		Invoice Description: iPHN CS/ FLAGS/ SCRN PRTCTR			
		001-410-516 SUPPLIES/OPERATING		70.17	
		Purchase Order #: 0 Voucher #: 175934 Invoice #: 16GG-TYQC-3JKG			146.02
		Invoice Description: RV PWR CNVRTR			
		001-410-618 RPR/MAINT EQUIPMENT		146.02	
		Purchase Order #: 0 Voucher #: 175935 Invoice #: 16MQ-XDPD-LG1N			224.39
		Invoice Description: BASS DRM PKS/ DRM DMPR/ TAPE			
		001-350-516 SUPPLIES/OPERATING		224.39	
		Purchase Order #: 0 Voucher #: 175936 Invoice #: 16MQ-XDPD-PXLQ			1,266.65
		Invoice Description: GOLF CLUBS			
		001-303-516 SUPPLIES/OPERATING		1,266.65	
		Purchase Order #: 0 Voucher #: 175937 Invoice #: 17H4-XCDH-191M			33.89

ACCOUNTS PAYABLE CHECK REGISTER

Check Register for 12/4/2025 to 12/17/2025 & Check Numbers 0 to 2147483647

Cash Account 001-000-011

Check Number	Check Date	Vendor Number / Name	Payment Type	EPay	Amount (\$)
<i>Invoice Description:</i>		LITHIUM BTTRIES			
001-100-516		SUPPLIES/OPERATING		33.89	
<i>Purchase Order #:</i>	0	<i>Voucher #:</i> 175938	<i>Invoice #:</i> 17N9-T1L7-4Y1D		152.00
<i>Invoice Description:</i>		FR EXTNGSHR BOX			
001-325-507		EQUIPMENT/SMALL		152.00	
<i>Purchase Order #:</i>	0	<i>Voucher #:</i> 175939	<i>Invoice #:</i> 17VN-LYJR-L7HN		164.69
<i>Invoice Description:</i>		SPRY PNT/ STNCLS			
001-200-516		SUPPLIES/OPERATING		164.69	
<i>Purchase Order #:</i>	0	<i>Voucher #:</i> 175940	<i>Invoice #:</i> 19FC-9XJT-494D		1,175.86
<i>Invoice Description:</i>		'VSNS' CSTMS/ PROPS/ LT CNTRLLR			
001-375-636		PRODUCTION COST		1,175.86	
<i>Purchase Order #:</i>	0	<i>Voucher #:</i> 175941	<i>Invoice #:</i> 19JC-YHQG-3RLJ		249.66
<i>Invoice Description:</i>		CMAS LTS/ CMAS TREE/ NO VHCL SGN			
430-682-507		EQUIPMENT/SMALL		249.66	
<i>Purchase Order #:</i>	0	<i>Voucher #:</i> 175942	<i>Invoice #:</i> 1D7Y-HJQ9-NP77		38.96
<i>Invoice Description:</i>		RSTRM/ FRNT DOOR/ RNG BLL SGNS			
001-609-724		REC CTR COMPLEX/CONTORNO		38.96	
<i>Purchase Order #:</i>	0	<i>Voucher #:</i> 175943	<i>Invoice #:</i> 1F49-Y6KD-4QCK		28.98
<i>Invoice Description:</i>		'VSNS' SHIRTS			
001-375-636		PRODUCTION COST		28.98	
<i>Purchase Order #:</i>	0	<i>Voucher #:</i> 175944	<i>Invoice #:</i> 1F74-4CN6-GMRL		53.05
<i>Invoice Description:</i>		BIRD FOOD			
001-410-516		SUPPLIES/OPERATING		53.05	
<i>Purchase Order #:</i>	0	<i>Voucher #:</i> 175945	<i>Invoice #:</i> 1FNT-PXGJ-9WG3		438.96
<i>Invoice Description:</i>		STRPPNG/ BCKLS			
001-200-516		SUPPLIES/OPERATING		438.96	
<i>Purchase Order #:</i>	0	<i>Voucher #:</i> 175946	<i>Invoice #:</i> 1FNW-YVPC-4C1P		433.18
<i>Invoice Description:</i>		MINI COMPUTERS			
001-325-507		EQUIPMENT/SMALL		433.18	
<i>Purchase Order #:</i>	0	<i>Voucher #:</i> 175947	<i>Invoice #:</i> 1GQ9-6RNP-M6YQ		460.20
<i>Invoice Description:</i>		CMAS LTS/ STL PLTS/ GRLND/ CRMPR			
001-200-516		SUPPLIES/OPERATING		460.20	
<i>Purchase Order #:</i>	0	<i>Voucher #:</i> 175948	<i>Invoice #:</i> 1GT1-6XCQ-FJN9		64.39
<i>Invoice Description:</i>		CAMERA CAGE			
001-301-516		SUPPLIES/OPERATING		64.39	
<i>Purchase Order #:</i>	0	<i>Voucher #:</i> 175949	<i>Invoice #:</i> 1LT4-RJLT-D6PR		329.34
<i>Invoice Description:</i>		STRPPNG BCKLS			
001-200-516		SUPPLIES/OPERATING		329.34	
<i>Purchase Order #:</i>	0	<i>Voucher #:</i> 175950	<i>Invoice #:</i> 1M7Q-7R3C-M9XP		199.96
<i>Invoice Description:</i>		iPAD KYBRD CASES/ PENS			
001-001-507		EQUIPMENT/SMALL		199.96	
<i>Purchase Order #:</i>	0	<i>Voucher #:</i> 175951	<i>Invoice #:</i> 1M9P-GK1G-79WG		109.99
<i>Invoice Description:</i>		CABLE			
001-200-516		SUPPLIES/OPERATING		109.99	
<i>Purchase Order #:</i>	0	<i>Voucher #:</i> 175952	<i>Invoice #:</i> 1M9P-GK1G-JH3D		254.77
<i>Invoice Description:</i>		WLL ART/ CMAS TREES/ ORNAMNTS			
403-676-516		SUPPLIES/OPERATING		254.77	
<i>Purchase Order #:</i>	0	<i>Voucher #:</i> 175953	<i>Invoice #:</i> 1NK6-H14N-JCHM		20.14

ACCOUNTS PAYABLE CHECK REGISTER

Check Register for 12/4/2025 to 12/17/2025 & Check Numbers 0 to 2147483647

Cash Account 001-000-011

Check Number	Check Date	Vendor Number / Name	Payment Type	EPay	Amount (\$)
		Invoice Description: STK TRLR SFTY CHN 001-200-618 RPR/MAINT EQUIPMENT			20.14
		Purchase Order #: 0 Voucher #: 175954 Invoice #: 1Q61-TFQH-DM13			139.96
		Invoice Description: SHORTS 403-676-540 UNIFORMS			139.96
		Purchase Order #: 0 Voucher #: 175955 Invoice #: 1QN4-CHFJ-6L31			78.04
		Invoice Description: PIN DSNLY CASES/ LPTP CHRGR 001-175-516 SUPPLIES/OPERATING			78.04
		Purchase Order #: 0 Voucher #: 175956 Invoice #: 1T4T-GFQD-97JX			398.20
		Invoice Description: FLAGS 001-001-516 SUPPLIES/OPERATING			398.20
		Purchase Order #: 0 Voucher #: 175957 Invoice #: 1T6T-PWWR-99KQ			61.95
		Invoice Description: #363,362 FLAGS 001-410-622 RPR/MAINT VEHICLES			61.95
		Purchase Order #: 0 Voucher #: 175958 Invoice #: 1TPF-G7X6-7714			46.99
		Invoice Description: RAIN SUIT 403-676-540 UNIFORMS			46.99
		Purchase Order #: 0 Voucher #: 175959 Invoice #: 1V3T-NGHK-44LX			-13.99
		Invoice Description: CRDT- PARTY DECOR 001-001-640 MISCELLANEOUS			-13.99
		Purchase Order #: 0 Voucher #: 175960 Invoice #: 1YDP-FKYH-4YWF			365.34
		Invoice Description: CMAS DECOR/ TBLCLTH/ CANDY 001-303-516 SUPPLIES/OPERATING			365.34
		Purchase Order #: 0 Voucher #: 175961 Invoice #: 1YWC-HLDX-DYYN			136.77
		Invoice Description: SHOES/ SHORTS 001-410-540 UNIFORMS			136.77
		Purchase Order #: 0 Voucher #: 175962 Invoice #: 1YWF-7L76-WX4Q			151.49
		Invoice Description: MCROWV/ USB C CBL 001-120-507 EQUIPMENT/SMALL			151.49
*****	12/17/2025	7572 AMERICAN TRADE MARK CO	Check	No	1,934.33
		Purchase Order #: 0 Voucher #: 175963 Invoice #: 00007578			1,934.33
		Invoice Description: IC STM/ OFCR BRDS/ TAG STG CS 001-175-507 EQUIPMENT/SMALL			1,934.33
*****	12/17/2025	7742 AMERITURF	Check	No	634.47
		Purchase Order #: 0 Voucher #: 175723 Invoice #: 89534			634.47
		Invoice Description: FRTLZR 001-303-620 RPR/MAINT GROUNDS			634.47
*****	12/17/2025	170 AMIC / MWCF	Check	No	280.00
		Purchase Order #: 0 Voucher #: 175567 Invoice #: 251119			280.00
		Invoice Description: 7 EMPL SKIDCAR TRN 001-100-630 TRAINING/TRAVEL			280.00
*****	12/17/2025	6114 AMY DIMARIO	Check	No	1,174.58
		Purchase Order #: 0 Voucher #: 175855 Invoice #: 251130			1,174.58
		Invoice Description: NOV 2025 430-682-660 RESALE INV/ARTISTS			1,174.58
*****	12/17/2025	7793 ANGEL ARMOR, LLC	Check	No	1,827.97

ACCOUNTS PAYABLE CHECK REGISTER

Check Register for 12/4/2025 to 12/17/2025 & Check Numbers 0 to 2147483647

Cash Account 001-000-011

Check Number	Check Date	Vendor Number / Name	Payment Type	EPay	Amount (\$)
		<i>Purchase Order #:</i> 0 <i>Voucher #:</i> 175964 <i>Invoice #:</i> INV16347			1,827.97
		<i>Invoice Description:</i> UNIFRM CRR/ BODY ARM/ PLCRD/ NM STRP 001-100-540 UNIFORMS			1,827.97
****	12/17/2025	7765 A PRECISION AUTO GLASS, INC	Check	No	339.20
		<i>Purchase Order #:</i> 0 <i>Voucher #:</i> 175568 <i>Invoice #:</i> D061134			339.20
		<i>Invoice Description:</i> #857 WNDSHLD 001-200-622 RPR/MAINT VEHICLES			339.20
****	12/17/2025	7430 AQUA PRO WATER SYSTEMS	Check	No	6,735.00
		<i>Purchase Order #:</i> 250548 <i>Voucher #:</i> 175569 <i>Invoice #:</i> 125160568			6,550.00
		<i>Invoice Description:</i> 45K LBS SALT 001-210-620 RPR/MAINT GROUNDS			6,550.00
		<i>Purchase Order #:</i> 0 <i>Voucher #:</i> 175570 <i>Invoice #:</i> 125167088			185.00
		<i>Invoice Description:</i> BRN VLV 001-210-516 SUPPLIES/OPERATING			185.00
****	12/17/2025	8165 ATHAN C. MARTIN	Check	No	273.01
		<i>Purchase Order #:</i> 0 <i>Voucher #:</i> 175856 <i>Invoice #:</i> 251130			273.01
		<i>Invoice Description:</i> NOV 2025 430-682-660 RESALE INV/ARTISTS			273.01
*	****	12/17/2025 8568 AUBURN AQUATICS SWIM PROGRAM, INC	Check	No	1,547.00
		<i>Purchase Order #:</i> 0 <i>Voucher #:</i> 175966 <i>Invoice #:</i> 1004			1,547.00
		<i>Invoice Description:</i> MEET ENTRIES 001-302-516 SUPPLIES/OPERATING			1,547.00
****	12/17/2025	8595 AUTO MEDIC WRECKER & TOWING	Check	No	120.00
		<i>Purchase Order #:</i> 0 <i>Voucher #:</i> 175571 <i>Invoice #:</i> 25-1119-172782			120.00
		<i>Invoice Description:</i> #274 JUMP START 001-100-622 RPR/MAINT VEHICLES			120.00
****	12/17/2025	778 AUTOWORX, LLC	Check	No	1,460.54
		<i>Purchase Order #:</i> 0 <i>Voucher #:</i> 175572 <i>Invoice #:</i> 096161			46.44
		<i>Invoice Description:</i> DISC \$0.95 #294 OIL/ FLTR 001-100-622 RPR/MAINT VEHICLES			46.44
		<i>Purchase Order #:</i> 0 <i>Voucher #:</i> 175573 <i>Invoice #:</i> 096162			68.39
		<i>Invoice Description:</i> DISC \$1.40 #409 OIL/ FLTR 001-175-510 GAS/OIL			51.87
		001-175-622 RPR/MAINT VEHICLES			16.52
		<i>Purchase Order #:</i> 0 <i>Voucher #:</i> 175574 <i>Invoice #:</i> 096166			66.99
		<i>Invoice Description:</i> DISC \$1.37 #23-205 OIL/ FLTR 001-100-622 RPR/MAINT VEHICLES			66.99
		<i>Purchase Order #:</i> 0 <i>Voucher #:</i> 175575 <i>Invoice #:</i> 096239			94.57
		<i>Invoice Description:</i> DISC \$1.93 STK HTR HOSE 001-210-516 SUPPLIES/OPERATING			94.57
		<i>Purchase Order #:</i> 0 <i>Voucher #:</i> 175576 <i>Invoice #:</i> 096263			60.14
		<i>Invoice Description:</i> DISC \$1.23 #802 OIL/ FLTR 001-210-510 GAS/OIL			54.69
		001-210-622 RPR/MAINT VEHICLES			5.45
		<i>Purchase Order #:</i> 0 <i>Voucher #:</i> 175577 <i>Invoice #:</i> 096349			66.99

ACCOUNTS PAYABLE CHECK REGISTER

Check Register for 12/4/2025 to 12/17/2025 & Check Numbers 0 to 2147483647

Cash Account 001-000-011

Check Number	Check Date	Vendor Number / Name	Payment Type	EPay	Amount (\$)
<i>Invoice Description:</i>		DISC \$1.37 #865 OIL/ FLTR			
	001-210-510	GAS/OIL		62.91	
	001-210-622	RPR/MAINT VEHICLES		4.08	
<i>Purchase Order #:</i>	0	<i>Voucher #:</i> 175724	<i>Invoice #:</i> 096224		66.99
<i>Invoice Description:</i>		DISC \$1.37 #289 OIL/ FLTR			
	001-100-622	RPR/MAINT VEHICLES		66.99	
<i>Purchase Order #:</i>	0	<i>Voucher #:</i> 175725	<i>Invoice #:</i> 096225		66.99
<i>Invoice Description:</i>		DISC \$1.37 #23-204 OIL/ FLTR			
	001-100-622	RPR/MAINT VEHICLES		66.99	
<i>Purchase Order #:</i>	0	<i>Voucher #:</i> 175726	<i>Invoice #:</i> 096261		66.99
<i>Invoice Description:</i>		DISC \$1.37 #214 OIL/ FLTR			
	001-100-622	RPR/MAINT VEHICLES		66.99	
<i>Purchase Order #:</i>	0	<i>Voucher #:</i> 175727	<i>Invoice #:</i> 096262		66.99
<i>Invoice Description:</i>		DISC \$1.37 #172 OIL/ FLTR			
	001-020-622	RPR/MAINT VEHICLES		66.99	
<i>Purchase Order #:</i>	0	<i>Voucher #:</i> 175728	<i>Invoice #:</i> 096313		60.14
<i>Invoice Description:</i>		DISC \$1.23 #244 OIL/ FLTR			
	001-100-622	RPR/MAINT VEHICLES		60.14	
<i>Purchase Order #:</i>	0	<i>Voucher #:</i> 175729	<i>Invoice #:</i> 096348		66.99
<i>Invoice Description:</i>		DISC \$1.37 #228A OIL/ FLTR			
	001-100-622	RPR/MAINT VEHICLES		66.99	
<i>Purchase Order #:</i>	0	<i>Voucher #:</i> 175967	<i>Invoice #:</i> 096315		22.07
<i>Invoice Description:</i>		DISC \$0.45 #797 OIL/ FLTR			
	001-303-622	RPR/MAINT VEHICLES		22.07	
<i>Purchase Order #:</i>	0	<i>Voucher #:</i> 175968	<i>Invoice #:</i> 096434		60.14
<i>Invoice Description:</i>		DISC \$1.23 #766 OIL/ FLTR			
	001-200-622	RPR/MAINT VEHICLES		5.45	
	001-200-510	GAS/OIL		54.69	
<i>Purchase Order #:</i>	0	<i>Voucher #:</i> 175969	<i>Invoice #:</i> 096435		5.34
<i>Invoice Description:</i>		DISC \$0.11 #7738 OIL FLTR			
	001-210-618	RPR/MAINT EQUIPMENT		5.34	
<i>Purchase Order #:</i>	0	<i>Voucher #:</i> 175970	<i>Invoice #:</i> 096437		60.14
<i>Invoice Description:</i>		DISC \$1.23 #296 OIL/ FLTR			
	001-100-622	RPR/MAINT VEHICLES		60.14	
<i>Purchase Order #:</i>	0	<i>Voucher #:</i> 175971	<i>Invoice #:</i> 096438		82.37
<i>Invoice Description:</i>		DISC \$1.68 #901 FLTRS			
	404-677-622	RPR/MAINT VEHICLES		82.37	
<i>Purchase Order #:</i>	0	<i>Voucher #:</i> 175972	<i>Invoice #:</i> 096439		19.24
<i>Invoice Description:</i>		DISC \$0.39 #705 OIL/ FLTR			
	001-200-510	GAS/OIL		14.06	
	001-200-622	RPR/MAINT VEHICLES		5.18	
<i>Purchase Order #:</i>	0	<i>Voucher #:</i> 175973	<i>Invoice #:</i> 096440		66.99
<i>Invoice Description:</i>		DISC \$1.37 #24-210 OIL/ FLTR			
	001-100-622	RPR/MAINT VEHICLES		66.99	
<i>Purchase Order #:</i>	0	<i>Voucher #:</i> 175974	<i>Invoice #:</i> 096441		60.14
<i>Invoice Description:</i>		DISC \$1.23 #23-203 OIL/ FLTR			
	001-100-622	RPR/MAINT VEHICLES		60.14	
<i>Purchase Order #:</i>	0	<i>Voucher #:</i> 175975	<i>Invoice #:</i> 096442		13.13

ACCOUNTS PAYABLE CHECK REGISTER

Check Register for 12/4/2025 to 12/17/2025 & Check Numbers 0 to 2147483647

Cash Account 001-000-011

Check Number	Check Date	Vendor Number / Name	Payment Type	EPay	Amount (\$)
		<i>Invoice Description:</i> DISC \$0.27 #903 FLTR 404-677-622 RPR/MAINT VEHICLES			13.13
		<i>Purchase Order #:</i> 0 <i>Voucher #:</i> 175976 <i>Invoice #:</i> 096443			53.29
		<i>Invoice Description:</i> DISC \$1.09 #450 OIL/ FLTR 001-175-510 GAS/OIL			48.93
		001-175-622 RPR/MAINT VEHICLES			4.36
		<i>Purchase Order #:</i> 0 <i>Voucher #:</i> 175977 <i>Invoice #:</i> 096482			60.14
		<i>Invoice Description:</i> DISC \$1.23 #272 OIL/ FLTR 001-100-622 RPR/MAINT VEHICLES			60.14
		<i>Purchase Order #:</i> 0 <i>Voucher #:</i> 175978 <i>Invoice #:</i> 096483			39.59
		<i>Invoice Description:</i> DISC \$0.81 #219 OIL/ FLTR 001-100-622 RPR/MAINT VEHICLES			39.59
		<i>Purchase Order #:</i> 0 <i>Voucher #:</i> 175979 <i>Invoice #:</i> 096595			66.99
		<i>Invoice Description:</i> DISC \$1.37 #205 OIL/ FLTR 001-100-622 RPR/MAINT VEHICLES			66.99
		<i>Purchase Order #:</i> 0 <i>Voucher #:</i> 175980 <i>Invoice #:</i> 096596			47.02
		<i>Invoice Description:</i> DISC \$0.96 #755 FLTRS 001-200-618 RPR/MAINT EQUIPMENT			47.02
		<i>Purchase Order #:</i> 0 <i>Voucher #:</i> 175981 <i>Invoice #:</i> 096597			5.34
		<i>Invoice Description:</i> DISC \$0.11 #792 FLTR 404-677-618 RPR/MAINT EQUIPMENT			5.34
*****	12/17/2025	241 BALDWIN COUNTY TREASURY	Check	No	123.00
		<i>Purchase Order #:</i> 0 <i>Voucher #:</i> 175847 <i>Invoice #:</i> 251201			123.00
		<i>Invoice Description:</i> NOV 2025 001-000-128 DUE COST FOR OTH AGENCIES			123.00
*****	12/17/2025	396 BALDWIN CTY COMMISSION	Check	No	1,926.14
		<i>Purchase Order #:</i> 0 <i>Voucher #:</i> 175982 <i>Invoice #:</i> 25.017			1,926.14
		<i>Invoice Description:</i> NAVY RD MAINT 001-608-720 ROADWAYS/PAVING/RESURFACE			1,926.14
*****	12/17/2025	215 BALDWIN CTY JUVENILE DETN FACILITY FD	Check	No	1,237.50
		<i>Purchase Order #:</i> 0 <i>Voucher #:</i> 175846 <i>Invoice #:</i> 251201			1,237.50
		<i>Invoice Description:</i> NOV 2025 001-000-128 DUE COST FOR OTH AGENCIES			1,237.50
*****	12/17/2025	231 BALDWIN PORTABLE TOILETS & SEPTIC TANK	Check	No	231.00
		<i>Purchase Order #:</i> 0 <i>Voucher #:</i> 175578 <i>Invoice #:</i> 315740			231.00
		<i>Invoice Description:</i> 10/23-11/19/25 TRN CRS 001-175-614 RENTALS			231.00
*****	12/17/2025	6325 BALDWIN SAND & GRAVEL LLC	Check	No	18,352.58
		<i>Purchase Order #:</i> 250518 <i>Voucher #:</i> 175730 <i>Invoice #:</i> 74024			18,352.58
		<i>Invoice Description:</i> 235.38 T ROCK 001-614-742 ADEM 319 GRANT			18,352.58
*****	12/17/2025	6493 BARBARA J. FRANCEZ	Check	No	150.00
		<i>Purchase Order #:</i> 0 <i>Voucher #:</i> 175668 <i>Invoice #:</i> 251121			90.00
		<i>Invoice Description:</i> CRDO DNC 001-325-612 PROFESSIONAL FEES			90.00

ACCOUNTS PAYABLE CHECK REGISTER

Check Register for 12/4/2025 to 12/17/2025 & Check Numbers 0 to 2147483647

Cash Account 001-000-011

Check Number	Check Date	Vendor Number / Name	Payment Type	EPay	Amount (\$)
<i>Purchase Order #:</i> 0		<i>Voucher #:</i> 175669	<i>Invoice #:</i> 251126		60.00
<i>Invoice Description:</i> CRDO DNC					
001-325-612		PROFESSIONAL FEES		60.00	
**** 12/17/2025		7943 BARBARA PRICE	Check	No	173.57
<i>Purchase Order #:</i> 0		<i>Voucher #:</i> 175857	<i>Invoice #:</i> 251130		173.57
<i>Invoice Description:</i> NOV 2025					
430-682-660		RESALE INVI/ARTISTS		173.57	
**** 12/17/2025		8269 BCC WASTE SOLUTIONS, LLC	Check	No	5,005.00
<i>Purchase Order #:</i> 250513		<i>Voucher #:</i> 175579	<i>Invoice #:</i> 0000697108		1,540.00
<i>Invoice Description:</i> 11/14-11/17/25 ROLLOFFS					
404-677-612		PROFESSIONAL FEES		1,540.00	
<i>Purchase Order #:</i> 250513		<i>Voucher #:</i> 175580	<i>Invoice #:</i> 0000698768		770.00
<i>Invoice Description:</i> 11/19/25 ROLLOFFS					
404-677-612		PROFESSIONAL FEES		770.00	
<i>Purchase Order #:</i> 0		<i>Voucher #:</i> 175983	<i>Invoice #:</i> 0000641004		385.00
<i>Invoice Description:</i> 07/10/25 RLLOFF					
001-609-724		REC CTR COMPLEX/CONTORNO		385.00	
<i>Purchase Order #:</i> 250383		<i>Voucher #:</i> 175984	<i>Invoice #:</i> 0000649540		385.00
<i>Invoice Description:</i> 07/31/25 RLLOFF					
404-677-612		PROFESSIONAL FEES		385.00	
<i>Purchase Order #:</i> 250513		<i>Voucher #:</i> 175985	<i>Invoice #:</i> 0000700249		1,925.00
<i>Invoice Description:</i> 11/20-11/25/25 RLOFFS					
404-677-612		PROFESSIONAL FEES		1,925.00	
**** 12/17/2025		240 BEARD EQUIPMENT COMPANY	Check	No	1,854.90
<i>Purchase Order #:</i> 0		<i>Voucher #:</i> 175581	<i>Invoice #:</i> 2221386		75.79
<i>Invoice Description:</i> #870 BSHNGS/ BOLTS/ SCRWS					
001-301-618		RPR/MAINT EQUIPMENT		75.79	
<i>Purchase Order #:</i> 0		<i>Voucher #:</i> 175731	<i>Invoice #:</i> 2211060		752.27
<i>Invoice Description:</i> STK EDGR BLDS/ CHUTES/ SHLDS					
001-301-618		RPR/MAINT EQUIPMENT		752.27	
<i>Purchase Order #:</i> 0		<i>Voucher #:</i> 175986	<i>Invoice #:</i> 2223221		35.00
<i>Invoice Description:</i> FRT FOR STRTR SHIP					
001-303-618		RPR/MAINT EQUIPMENT		35.00	
<i>Purchase Order #:</i> 0		<i>Voucher #:</i> 175987	<i>Invoice #:</i> 2223222		121.33
<i>Invoice Description:</i> SPRYR STRTR					
001-303-618		RPR/MAINT EQUIPMENT		121.33	
<i>Purchase Order #:</i> 0		<i>Voucher #:</i> 175988	<i>Invoice #:</i> 2227154		870.51
<i>Invoice Description:</i> MOWER BLDS/ SCRWS/ NUTS					
001-301-516		SUPPLIES/OPERATING		870.51	
**** 12/17/2025		245 BELL STEEL COMPANY	Check	No	891.95
<i>Purchase Order #:</i> 0		<i>Voucher #:</i> 175582	<i>Invoice #:</i> 0091357		722.03
<i>Invoice Description:</i> TUBE STL/ FLAT MTL/ ANGL MTL					
001-210-618		RPR/MAINT EQUIPMENT		722.03	
<i>Purchase Order #:</i> 0		<i>Voucher #:</i> 175989	<i>Invoice #:</i> 0091454		169.92
<i>Invoice Description:</i> 20' RODS - 12					
001-200-620		RPR/MAINT GROUNDS		169.92	

ACCOUNTS PAYABLE CHECK REGISTER

Check Register for 12/4/2025 to 12/17/2025 & Check Numbers 0 to 2147483647

Cash Account 001-000-011

Check Number	Check Date	Vendor Number / Name	Payment Type	EPay	Amount (\$)
****	12/17/2025	7101 BLUE 360 MEDIA, LLC	Check	No	1,126.74
		Purchase Order #: 0 Voucher #: 175583 Invoice #: IN2509270218			1,126.74
		Invoice Description: AL MTR VEH LAWS BKS			
		001-100-612 PROFESSIONAL FEES			1,126.74
****	12/17/2025	8875 BLUE AV	Check	No	67,691.25
		Purchase Order #: 250575 Voucher #: 175990 Invoice #: 1139			67,691.25
		Invoice Description: AV SYSTEM			
		001-375-507 EQUIPMENT/SMALL			67,691.25
****	12/17/2025	6902 BLUE GIRL BEADING	Check	No	92.95
		Purchase Order #: 0 Voucher #: 175858 Invoice #: 251130			92.95
		Invoice Description: NOV 2025			
		430-682-660 RESALE INVI/ARTISTS			92.95
****	12/17/2025	6288 BRANDY THOMLEY	Check	No	297.73
		Purchase Order #: 0 Voucher #: 175859 Invoice #: 251130			297.73
		Invoice Description: NOV 2025			
		430-682-660 RESALE INVI/ARTISTS			297.73
****	12/17/2025	7141 BRITTNEY RUSH	Check	No	450.00
		Purchase Order #: 0 Voucher #: 175991 Invoice #: SWPC-2025-001			450.00
		Invoice Description: CITY CNCL PORTRTS			
		001-001-612 PROFESSIONAL FEES			450.00
****	12/17/2025	223 BSN SPORTS LLC	Check	No	882.02
		Purchase Order #: 0 Voucher #: 175732 Invoice #: 932192492			56.52
		Invoice Description: SCCR JERSEY			
		001-301-516 SUPPLIES/OPERATING			56.52
		Purchase Order #: 0 Voucher #: 175992 Invoice #: 932267690			825.50
		Invoice Description: WINDSCREEN			
		001-301-516 SUPPLIES/OPERATING			825.50
****	12/17/2025	5359 BUDWEISER-BUSCH DIST. CO.	Check	No	537.22
		Purchase Order #: 0 Voucher #: 175993 Invoice #: 1064525			537.22
		Invoice Description: BEER			
		001-303-660 COST OF GOODS SOLD RETAIL			537.22
****	12/17/2025	5420 BWI COMPANIES, INC.	Check	No	1,190.03
		Purchase Order #: 0 Voucher #: 175584 Invoice #: 19439531			1,190.03
		Invoice Description: FCT PRCTCTRS/ SPRNKLRS/ WTR HS			
		001-210-516 SUPPLIES/OPERATING			1,190.03
****	12/17/2025	7505 CALEB TERRY	Check	No	32.00
		Purchase Order #: 0 Voucher #: 175585 Invoice #: 251120			32.00
		Invoice Description: RMB NAT'L EMT RNWL			
		001-175-608 DUES/MEMBERSHIP/SUBSCRIPT			32.00
****	12/17/2025	6673 CARMEN W. WATKINS	Check	No	150.00
		Purchase Order #: 0 Voucher #: 175670 Invoice #: 221121			90.00
		Invoice Description: YOGA			
		001-325-612 PROFESSIONAL FEES			90.00
		Purchase Order #: 0 Voucher #: 175671 Invoice #: 251126			60.00

ACCOUNTS PAYABLE CHECK REGISTER

Check Register for 12/4/2025 to 12/17/2025 & Check Numbers 0 to 2147483647

Cash Account 001-000-011

Check Number	Check Date	Vendor Number / Name	Payment Type	EPay	Amount (\$)
		<i>Invoice Description:</i> YOGA 001-325-612 PROFESSIONAL FEES			60.00
*****	12/17/2025	8446 CAROL C DAVIS	Check	No	120.00
		<i>Purchase Order #:</i> 0 <i>Voucher #:</i> 175672 <i>Invoice #:</i> 251126			120.00
		<i>Invoice Description:</i> INDR CYCL/ HIIT 001-325-612 PROFESSIONAL FEES			120.00
*****	12/17/2025	5131 CAROLYN WAGNER	Check	No	16.25
		<i>Purchase Order #:</i> 0 <i>Voucher #:</i> 175860 <i>Invoice #:</i> 251130			16.25
		<i>Invoice Description:</i> NOV 2025 430-682-660 RESALE INV/ARTISTS			16.25
*****	12/17/2025	6351 CATHERINE ELLIOTT	Check	No	32.50
		<i>Purchase Order #:</i> 0 <i>Voucher #:</i> 175861 <i>Invoice #:</i> 251130			32.50
		<i>Invoice Description:</i> NOV 2025 430-682-660 RESALE INV/ARTISTS			32.50
*****	12/17/2025	4077 CATHY PASCOE	Check	No	17.55
		<i>Purchase Order #:</i> 0 <i>Voucher #:</i> 175862 <i>Invoice #:</i> 251031			6.50
		<i>Invoice Description:</i> OCT 2025 430-682-660 RESALE INV/ARTISTS			6.50
		<i>Purchase Order #:</i> 0 <i>Voucher #:</i> 175863 <i>Invoice #:</i> 251130			11.05
		<i>Invoice Description:</i> NOV 2025 430-682-660 RESALE INV/ARTISTS			11.05
*****	12/17/2025	6437 CHAPTER 13 TRUSTEE	Check	No	321.50
		<i>Purchase Order #:</i> 0 <i>Voucher #:</i> 175994 <i>Invoice #:</i> 112825-TABB			321.50
		<i>Invoice Description:</i> 24-11011-HAC-13 001-000-104 GARNISHMENT/SAVINGS			321.50
*****	12/17/2025	7278 CINTAS CORPORATION NO. 2	Check	No	96.44
		<i>Purchase Order #:</i> 0 <i>Voucher #:</i> 175733 <i>Invoice #:</i> 4250969025			48.22
		<i>Invoice Description:</i> WEEKLY SVC 430-682-612 PROFESSIONAL FEES			48.22
		<i>Purchase Order #:</i> 0 <i>Voucher #:</i> 175995 <i>Invoice #:</i> 4251704109			48.22
		<i>Invoice Description:</i> WEEKLY SVC 430-682-612 PROFESSIONAL FEES			48.22
*****	12/17/2025	351 CIRCUIT CLERK	Check	No	435.00
		<i>Purchase Order #:</i> 0 <i>Voucher #:</i> 175996 <i>Invoice #:</i> 112825-WHITE			217.50
		<i>Invoice Description:</i> 05-CV-2017-901105.00 001-000-104 GARNISHMENT/SAVINGS			217.50
		<i>Purchase Order #:</i> 0 <i>Voucher #:</i> 175997 <i>Invoice #:</i> 112825-WOODRING PISH			217.50
		<i>Invoice Description:</i> 05-CV-2023-900882.00 001-000-104 GARNISHMENT/SAVINGS			217.50
*****	12/17/2025	5957 CIRCUIT CLERKS' JUDICIAL ADMIN FUND	Check	No	180.19
		<i>Purchase Order #:</i> 0 <i>Voucher #:</i> 175848 <i>Invoice #:</i> 251201			180.19
		<i>Invoice Description:</i> NOV 2025 001-000-128 DUE COST FOR OTH AGENCIES			180.19
*****	12/17/2025	5956 CIRCUIT JUDGES' JUDICIAL ADMIN FUND	Check	No	180.19

ACCOUNTS PAYABLE CHECK REGISTER

Check Register for 12/4/2025 to 12/17/2025 & Check Numbers 0 to 2147483647

Cash Account 001-000-011

Check Number	Check Date	Vendor Number / Name	Payment Type	EPay	Amount (\$)
		Purchase Order #: 0 Voucher #: 175849 Invoice #: 251201			180.19
		Invoice Description: NOV 2025			
		001-000-128 DUE COST FOR OTH AGENCIES		180.19	
****	12/17/2025	7850 CLARE L. WILDER	Check	No	13.00
		Purchase Order #: 0 Voucher #: 175864 Invoice #: 251130			13.00
		Invoice Description: NOV 2025			
		430-682-660 RESALE INVI/ARTISTS		13.00	
****	12/17/2025	3407 CLEVERDON FARM INC.	Check	No	376.50
		Purchase Order #: 0 Voucher #: 175586 Invoice #: 96308			376.50
		Invoice Description: 3 PLLTS BERMUDA SOD			
		001-210-620 RPR/MAINT GROUNDS		376.50	
****	12/17/2025	99 COASTAL AL BUSINESS CHAMBER	Check	No	360.00
		Purchase Order #: 0 Voucher #: 175998 Invoice #: 28320			360.00
		Invoice Description: POWHER HR Q4			
		001-001-630 TRAINING/TRAVEL		360.00	
****	12/17/2025	3427 COASTAL ARTS CENTER OF ORANGE BEACH	Check	No	300.00
		Purchase Order #: 0 Voucher #: 175999 Invoice #: 251121			300.00
		Invoice Description: LFGRD OF YR AWRD			
		001-175-516 SUPPLIES/OPERATING		300.00	
****	12/17/2025	8218 COASTAL CREATIONS	Check	No	496.61
		Purchase Order #: 0 Voucher #: 175865 Invoice #: 251130			496.61
		Invoice Description: NOV 2025			
		430-682-660 RESALE INVI/ARTISTS		496.61	
****	12/17/2025	8884 COASTAL MARQUEE LLC	Check	No	100.00
		Purchase Order #: 0 Voucher #: 176000 Invoice #: 55716-000464			100.00
		Invoice Description: VET DAY LTTRS			
		001-001-650 EXHIBITIONS & PROMOTIONS		100.00	
****	12/17/2025	8693 COASTAL WAVE DIAGNOSTICS, LLC	Check	No	900.00
		Purchase Order #: 0 Voucher #: 176001 Invoice #: 251125			900.00
		Invoice Description: 9 SCANS			
		001-001-612 PROFESSIONAL FEES		900.00	
****	12/17/2025	319 COCA-COLA BOTTLING CO	Check	No	1,006.00
		Purchase Order #: 250261 Voucher #: 176002 Invoice #: 49977039004			587.50
		Invoice Description: VENDING/ CONCESSIONS			
		001-301-516 SUPPLIES/OPERATING		587.50	
		Purchase Order #: 0 Voucher #: 176003 Invoice #: 49977039025			418.50
		Invoice Description: BTTLD WTR			
		001-175-516 SUPPLIES/OPERATING		418.50	
****	12/17/2025	8867 COLLIN M. TACHENY	Check	No	299.01
		Purchase Order #: 0 Voucher #: 175866 Invoice #: 251130			299.01
		Invoice Description: NOV 2025			
		430-682-660 RESALE INVI/ARTISTS		299.01	
****	12/17/2025	7805 COMMUNITY COFFEE COMPANY, LLC	Check	No	469.72
		Purchase Order #: 0 Voucher #: 175734 Invoice #: 12146533012			469.72

ACCOUNTS PAYABLE CHECK REGISTER

Check Register for 12/4/2025 to 12/17/2025 & Check Numbers 0 to 2147483647

Cash Account 001-000-011

Check Number	Check Date	Vendor Number / Name	Payment Type	EPay	Amount (\$)
		<i>Invoice Description:</i> COFFEE SPPLS 001-325-516 SUPPLIES/OPERATING			469.72
*****	12/17/2025	390 COMPROLLER STATE OF AL	Check	No	6,385.82
		<i>Purchase Order #:</i> 0 <i>Voucher #:</i> 175851 <i>Invoice #:</i> 251201			6,385.82
		<i>Invoice Description:</i> NOV 2025 001-000-128 DUE COST FOR OTH AGENCIES			6,385.82
*****	12/17/2025	381 COMPUTER BACKUP, INC	Check	No	11,495.00
		<i>Purchase Order #:</i> 0 <i>Voucher #:</i> 176004 <i>Invoice #:</i> 30953			995.00
		<i>Invoice Description:</i> ACCESS FIREWALL 403-676-616 RPR/MAINT PLANT/BLDGS			995.00
		<i>Purchase Order #:</i> 0 <i>Voucher #:</i> 176005 <i>Invoice #:</i> 30971			10,500.00
		<i>Invoice Description:</i> NOV 2025 001-001-612 PROFESSIONAL FEES			10,500.00
*****	12/17/2025	8799 CORTNEY N. SHAWVER	Check	No	104.00
		<i>Purchase Order #:</i> 0 <i>Voucher #:</i> 175867 <i>Invoice #:</i> 251130			104.00
		<i>Invoice Description:</i> NOV 2025 430-682-660 RESALE INV/ARTISTS			104.00
*****	12/17/2025	7005 COUCH AGGREGATES LLC	Check	No	1,183.88
		<i>Purchase Order #:</i> 0 <i>Voucher #:</i> 176006 <i>Invoice #:</i> 183234			1,183.88
		<i>Invoice Description:</i> 34.82 T RECYCLD CNCRT 001-200-620 RPR/MAINT GROUNDS			1,183.88
*****	12/17/2025	399 CRAFT TURF FARMS	Check	No	192.00
		<i>Purchase Order #:</i> 0 <i>Voucher #:</i> 175587 <i>Invoice #:</i> 44802			192.00
		<i>Invoice Description:</i> 2 PLLTS BERMUDA SOD 001-210-620 RPR/MAINT GROUNDS			192.00
*****	12/17/2025	6397 DANIEL W. RUSH	Check	No	468.02
		<i>Purchase Order #:</i> 0 <i>Voucher #:</i> 175868 <i>Invoice #:</i> 251130			468.02
		<i>Invoice Description:</i> NOV 2025 430-682-660 RESALE INV/ARTISTS			468.02
*****	12/17/2025	8178 DERRICK J CLARKE	Check	No	45.00
		<i>Purchase Order #:</i> 0 <i>Voucher #:</i> 176007 <i>Invoice #:</i> 251201			45.00
		<i>Invoice Description:</i> RMB PSTCD APPLCTR PRMT 001-210-630 TRAINING/TRAVEL			45.00
*****	12/17/2025	6281 DESIGN PRINT PROMOTE, LLC	Check	No	175.22
		<i>Purchase Order #:</i> 0 <i>Voucher #:</i> 176008 <i>Invoice #:</i> 07212025.XKSM-01			20.00
		<i>Invoice Description:</i> DESIGN FEE 430-682-650 EXHIBITIONS & PROMOTIONS			20.00
		<i>Purchase Order #:</i> 0 <i>Voucher #:</i> 176009 <i>Invoice #:</i> 09102025.CREDIT			-93.88
		<i>Invoice Description:</i> OVRPD INV 09102025.WNZG 001-001-650 EXHIBITIONS & PROMOTIONS			-93.88
		<i>Purchase Order #:</i> 0 <i>Voucher #:</i> 176010 <i>Invoice #:</i> 12022025.XJNF-01			249.10
		<i>Invoice Description:</i> POSTCARDS 430-682-507 EQUIPMENT/SMALL			249.10
*****	12/17/2025	3834 DISTRICT ATTORNEY SOLICITORS FUND	Check	No	1,911.33

ACCOUNTS PAYABLE CHECK REGISTER

Check Register for 12/4/2025 to 12/17/2025 & Check Numbers 0 to 2147483647

Cash Account 001-000-011

Check Number	Check Date	Vendor Number / Name	Payment Type	EPay	Amount (\$)
<i>Purchase Order #:</i> 0		<i>Voucher #:</i> 175845	<i>Invoice #:</i> 251201		1,911.33
<i>Invoice Description:</i>	NOV 2025				
001-000-128	DUE COST FOR OTH AGENCIES			1,911.33	
**** 12/17/2025	212 DOMESTIC VIOLENCE SHELTER FUND		Check	No	25.00
<i>Purchase Order #:</i> 0		<i>Voucher #:</i> 175852	<i>Invoice #:</i> 251201		25.00
<i>Invoice Description:</i>	NOV 2025				
001-000-128	DUE COST FOR OTH AGENCIES			25.00	
**** 12/17/2025	6865 DONALD & GIZELLE BORWHAT		Check	No	51.94
<i>Purchase Order #:</i> 0		<i>Voucher #:</i> 175869	<i>Invoice #:</i> 251130		51.94
<i>Invoice Description:</i>	NOV 2025				
430-682-660	RESALE INVI/ARTISTS			51.94	
**** 12/17/2025	7465 DONNA TURBYFILL		Check	No	451.75
<i>Purchase Order #:</i> 0		<i>Voucher #:</i> 175870	<i>Invoice #:</i> 251130		451.75
<i>Invoice Description:</i>	NOV 2025				
430-682-660	RESALE INVI/ARTISTS			451.75	
**** 12/17/2025	8434 DUNLOP SPORTS AMERICAS		Check	No	937.70
<i>Purchase Order #:</i> 0		<i>Voucher #:</i> 176011	<i>Invoice #:</i> 8616472 SO		720.36
<i>Invoice Description:</i>	GRIPS				
001-303-660	COST OF GOODS SOLD RETAIL			720.36	
<i>Purchase Order #:</i> 0		<i>Voucher #:</i> 176012	<i>Invoice #:</i> 8723402 CA		-720.36
<i>Invoice Description:</i>	CRDT- GRPS				
001-303-660	COST OF GOODS SOLD RETAIL			-720.36	
<i>Purchase Order #:</i> 0		<i>Voucher #:</i> 176013	<i>Invoice #:</i> 8728500 SO		937.70
<i>Invoice Description:</i>	GOLF BALLS				
001-303-660	COST OF GOODS SOLD RETAIL			937.70	
**** 12/17/2025	7503 EA ENGINEERING, SCIENCE & TECHNOLOGY INC		Check	No	2,800.00
<i>Purchase Order #:</i> 0		<i>Voucher #:</i> 176014	<i>Invoice #:</i> 000000012607		1,400.00
<i>Invoice Description:</i>	TOXICITY TSTNG				
403-676-612	PROFESSIONAL FEES			1,400.00	
<i>Purchase Order #:</i> 0		<i>Voucher #:</i> 176015	<i>Invoice #:</i> 168027		1,400.00
<i>Invoice Description:</i>	TOXICITY TSTNG				
403-676-612	PROFESSIONAL FEES			1,400.00	
**** 12/17/2025	3852 EASY PICKER GOLF PRODUCTS INC.		Check	No	1,538.37
<i>Purchase Order #:</i> 0		<i>Voucher #:</i> 176016	<i>Invoice #:</i> 0226153-IN		1,479.37
<i>Invoice Description:</i>	FLGSTKS/ BSKTS/ CUPS				
001-303-516	SUPPLIES/OPERATING			1,479.37	
<i>Purchase Order #:</i> 0		<i>Voucher #:</i> 176017	<i>Invoice #:</i> 0226168-IN		59.00
<i>Invoice Description:</i>	CUP CVRS				
001-303-516	SUPPLIES/OPERATING			59.00	
**** 12/17/2025	541 EBERT AGENCY, INC.		Check	No	141.00
<i>Purchase Order #:</i> 0		<i>Voucher #:</i> 175740	<i>Invoice #:</i> 1355		141.00
<i>Invoice Description:</i>	J CLOUSE NTRY RNWL				
001-100-612	PROFESSIONAL FEES			141.00	
**** 12/17/2025	6064 ELLEN V. RODGERS		Check	No	224.28
<i>Purchase Order #:</i> 0		<i>Voucher #:</i> 175871	<i>Invoice #:</i> 251130		224.28

ACCOUNTS PAYABLE CHECK REGISTER

Check Register for 12/4/2025 to 12/17/2025 & Check Numbers 0 to 2147483647

Cash Account 001-000-011

Check Number	Check Date	Vendor Number / Name	Payment Type	EPay	Amount (\$)
Invoice Description:		NOV 2025			
		430-682-660 RESALE INV/ARTISTS			224.28
*****	12/17/2025	5756 EMERALD COAST CARPET CLEANING	Check	No	854.78
	Purchase Order #:	0	Voucher #: 176018	Invoice #: 31783	854.78
Invoice Description:		COMM CTR CRPT CLN			
		411-681-616 RPR/MAINT BUILDING			854.78
*****	12/17/2025	5849 EMERGENCY EQUIPMENT PROFESSIONALS	Check	No	14,094.00
	Purchase Order #:	0	Voucher #: 176019	Invoice #: 522746	1,480.00
Invoice Description:		BOOTS			
		001-175-507 EQUIPMENT/SMALL			1,480.00
	Purchase Order #:	250574	Voucher #: 176020	Invoice #: 522758	12,614.00
Invoice Description:		#429 HSKY STM RPL			
		001-175-622 RPR/MAINT VEHICLES			12,614.00
*****	12/17/2025	8571 ENVIRONMENTAL ENTERPRISES USA, INC.	Check	No	1,124.16
	Purchase Order #:	0	Voucher #: 176021	Invoice #: 131580	1,124.16
Invoice Description:		TOXICITY TESTING			
		403-676-612 PROFESSIONAL FEES			1,124.16
*****	12/17/2025	1909 EUOFINS ENVIRONMENT TESTING SOUTHEAST	Check	No	480.00
	Purchase Order #:	0	Voucher #: 176022	Invoice #: 4000169707	480.00
Invoice Description:		LAB SMPLS			
		403-676-612 PROFESSIONAL FEES			480.00
*****	12/17/2025	3170 FERGUSON ENTERPRISES, INC #1204	Check	No	1,800.00
	Purchase Order #:	0	Voucher #: 176023	Invoice #: 1618376	1,800.00
Invoice Description:		FLANGE KITS			
		403-676-516 SUPPLIES/OPERATING			1,800.00
*****	12/17/2025	3612 FIRST CALL	Check	No	2,126.94
	Purchase Order #:	0	Voucher #: 175588	Invoice #: 1133-382443	22.20
Invoice Description:		#294 WPR BLDS			
		001-100-622 RPR/MAINT VEHICLES			22.20
	Purchase Order #:	0	Voucher #: 175589	Invoice #: 1133-382445	76.83
Invoice Description:		#289 THRMOST HSNG/ CLNT TMP SNSR			
		001-100-622 RPR/MAINT VEHICLES			76.83
	Purchase Order #:	0	Voucher #: 175590	Invoice #: 1133-383458	19.11
Invoice Description:		STK OIL DRN PLGS			
		001-200-516 SUPPLIES/OPERATING			19.11
	Purchase Order #:	0	Voucher #: 175591	Invoice #: 1133-383459	16.16
Invoice Description:		#801 DRN PLGS			
		001-210-622 RPR/MAINT VEHICLES			16.16
	Purchase Order #:	0	Voucher #: 175592	Invoice #: 1133-382460	66.69
Invoice Description:		#462 COP COIL/ SPK PLGS			
		001-175-622 RPR/MAINT VEHICLES			66.69
	Purchase Order #:	0	Voucher #: 175593	Invoice #: 1133-383465	4.71
Invoice Description:		#802 OIL DRN PLG			
		001-210-622 RPR/MAINT VEHICLES			4.71
	Purchase Order #:	0	Voucher #: 175594	Invoice #: 1133-383736	133.95

ACCOUNTS PAYABLE CHECK REGISTER

Check Register for 12/4/2025 to 12/17/2025 & Check Numbers 0 to 2147483647

Cash Account 001-000-011

Check Number	Check Date	Vendor Number / Name	Payment Type	EPay	Amount (\$)
		<i>Invoice Description:</i> #854 SPK PLGS/ IGN WR SET			
		001-200-622 RPR/MAINT VEHICLES		133.95	
		<i>Purchase Order #:</i> 0 <i>Voucher #:</i> 175595 <i>Invoice #:</i> 1133-383753			180.32
		<i>Invoice Description:</i> #867 WTR PMP/ BLT/ THRMOST			
		001-210-622 RPR/MAINT VEHICLES		180.32	
		<i>Purchase Order #:</i> 0 <i>Voucher #:</i> 175596 <i>Invoice #:</i> 1133-383854			0.99
		<i>Invoice Description:</i> #867 GASKET			
		001-210-622 RPR/MAINT VEHICLES		0.99	
		<i>Purchase Order #:</i> 0 <i>Voucher #:</i> 175597 <i>Invoice #:</i> 1133-383966			22.98
		<i>Invoice Description:</i> #865 SWAY LNK KITS			
		001-210-622 RPR/MAINT VEHICLES		22.98	
		<i>Purchase Order #:</i> 0 <i>Voucher #:</i> 175598 <i>Invoice #:</i> 1133-383977			67.22
		<i>Invoice Description:</i> #904 EXHST HRDWR			
		404-677-622 RPR/MAINT VEHICLES		67.22	
		<i>Purchase Order #:</i> 0 <i>Voucher #:</i> 175741 <i>Invoice #:</i> 1133-383313			56.97
		<i>Invoice Description:</i> #247 OIL/ SLIP ADD			
		001-100-622 RPR/MAINT VEHICLES		56.97	
		<i>Purchase Order #:</i> 0 <i>Voucher #:</i> 175742 <i>Invoice #:</i> 1133-383457			56.97
		<i>Invoice Description:</i> #244 OIL/ SLIP ADD			
		001-100-622 RPR/MAINT VEHICLES		56.97	
		<i>Purchase Order #:</i> 0 <i>Voucher #:</i> 175743 <i>Invoice #:</i> 1133-383462			22.20
		<i>Invoice Description:</i> #172 WPR BLDS			
		001-020-622 RPR/MAINT VEHICLES		22.20	
		<i>Purchase Order #:</i> 0 <i>Voucher #:</i> 175744 <i>Invoice #:</i> 1133-383527			144.39
		<i>Invoice Description:</i> #299 FUEL PMP			
		001-100-622 RPR/MAINT VEHICLES		144.39	
		<i>Purchase Order #:</i> 0 <i>Voucher #:</i> 175745 <i>Invoice #:</i> 1133-383528			7.96
		<i>Invoice Description:</i> #299 FUEL FLTR			
		001-100-622 RPR/MAINT VEHICLES		7.96	
		<i>Purchase Order #:</i> 0 <i>Voucher #:</i> 175746 <i>Invoice #:</i> 5491-364389			32.99
		<i>Invoice Description:</i> #363 TOW STRAP			
		001-410-622 RPR/MAINT VEHICLES		32.99	
		<i>Purchase Order #:</i> 0 <i>Voucher #:</i> 175747 <i>Invoice #:</i> 5491-364478			19.96
		<i>Invoice Description:</i> #355 FLX TUBE/ MFFLR CLMPS			
		001-614-743 NRDA MARINE DEBRIS GRANT		19.96	
		<i>Purchase Order #:</i> 0 <i>Voucher #:</i> 176024 <i>Invoice #:</i> 1133-384064			21.99
		<i>Invoice Description:</i> #662 SOCKET			
		403-676-622 RPR/MAINT VEHICLES		21.99	
		<i>Purchase Order #:</i> 0 <i>Voucher #:</i> 176025 <i>Invoice #:</i> 1133-384236			21.99
		<i>Invoice Description:</i> #854 HDLT SOCKET			
		001-200-622 RPR/MAINT VEHICLES		21.99	
		<i>Purchase Order #:</i> 0 <i>Voucher #:</i> 176026 <i>Invoice #:</i> 1133-384910			22.20
		<i>Invoice Description:</i> #296 WPR BLDS			
		001-100-622 RPR/MAINT VEHICLES		22.20	
		<i>Purchase Order #:</i> 0 <i>Voucher #:</i> 176027 <i>Invoice #:</i> 1133-384977			145.46
		<i>Invoice Description:</i> #111 BATTERY			
		001-100-622 RPR/MAINT VEHICLES		145.46	
		<i>Purchase Order #:</i> 0 <i>Voucher #:</i> 176028 <i>Invoice #:</i> 1133-386468			35.98

ACCOUNTS PAYABLE CHECK REGISTER

Check Register for 12/4/2025 to 12/17/2025 & Check Numbers 0 to 2147483647

Cash Account 001-000-011

Check Number	Check Date	Vendor Number / Name	Payment Type	EPay	Amount (\$)
		<i>Invoice Description:</i> STK O-RNGS			
		001-200-516 SUPPLIES/OPERATING			35.98
		<i>Purchase Order #:</i> 0 <i>Voucher #:</i> 176029 <i>Invoice #:</i> 5330-462085			218.39
		<i>Invoice Description:</i> #296 BATTERY			
		001-100-622 RPR/MAINT VEHICLES			218.39
		<i>Purchase Order #:</i> 0 <i>Voucher #:</i> 176030 <i>Invoice #:</i> 5491-364499			115.99
		<i>Invoice Description:</i> #662 DEF FLD/ CAR WSH			
		403-676-516 SUPPLIES/OPERATING			115.99
		<i>Purchase Order #:</i> 0 <i>Voucher #:</i> 176031 <i>Invoice #:</i> 5491-365051			19.99
		<i>Invoice Description:</i> STK ANTIFRZ			
		403-676-616 RPR/MAINT PLANT/BLDGS			19.99
		<i>Purchase Order #:</i> 0 <i>Voucher #:</i> 176032 <i>Invoice #:</i> 5491-365127			137.94
		<i>Invoice Description:</i> STK ANTIFRZ			
		403-676-616 RPR/MAINT PLANT/BLDGS			137.94
		<i>Purchase Order #:</i> 0 <i>Voucher #:</i> 176033 <i>Invoice #:</i> 5491-365150			29.49
		<i>Invoice Description:</i> #664,662 WPR BLDS			
		403-676-622 RPR/MAINT VEHICLES			29.49
		<i>Purchase Order #:</i> 0 <i>Voucher #:</i> 176034 <i>Invoice #:</i> 5491-365195			161.92
		<i>Invoice Description:</i> STK TOOL SET/ SKT SET/ DRL/ SKT EXTN			
		001-200-516 SUPPLIES/OPERATING			161.92
		<i>Purchase Order #:</i> 0 <i>Voucher #:</i> 176035 <i>Invoice #:</i> 5491-365736			243.00
		<i>Invoice Description:</i> #7105 BATTERIES			
		001-301-618 RPR/MAINT EQUIPMENT			243.00
*****	12/17/2025	6850 FORTILINE WATERWORKS	Check	No	913.35
		<i>Purchase Order #:</i> 0 <i>Voucher #:</i> 175748 <i>Invoice #:</i> 7157312			826.81
		<i>Invoice Description:</i> TEES/ CPLNGS			
		001-614-742 ADEM 319 GRANT			826.81
		<i>Purchase Order #:</i> 0 <i>Voucher #:</i> 176036 <i>Invoice #:</i> 7167026			86.54
		<i>Invoice Description:</i> 18" GRATE			
		001-608-720 ROADWAYS/PAVING/RESURFACE			86.54
*****	12/17/2025	7344 FOX VALLEY ANIMAL NUTRITION INC	Check	No	277.15
		<i>Purchase Order #:</i> 0 <i>Voucher #:</i> 176037 <i>Invoice #:</i> 73524			277.15
		<i>Invoice Description:</i> SQRRL FOOD			
		001-410-516 SUPPLIES/OPERATING			277.15
*****	12/17/2025	6483 GARAGE DOOR RESCUE, INC	Check	No	234.00
		<i>Purchase Order #:</i> 0 <i>Voucher #:</i> 176038 <i>Invoice #:</i> INV-0235			104.00
		<i>Invoice Description:</i> GRG DOOR DIAGNOSE			
		001-609-724 REC CTR COMPLEX/CONTORNO			104.00
		<i>Purchase Order #:</i> 0 <i>Voucher #:</i> 176039 <i>Invoice #:</i> INV-0237			130.00
		<i>Invoice Description:</i> GRG DR LUBE			
		001-301-616 RPR/MAINT PLANT/BLDGS			130.00
*****	12/17/2025	8874 GERALD W. MILLS III	Check	No	1,918.00
		<i>Purchase Order #:</i> 0 <i>Voucher #:</i> 176040 <i>Invoice #:</i> 12012025			1,918.00
		<i>Invoice Description:</i> 'FRZN' 1 OF 2			
		001-375-612 PROFESSIONAL FEES			1,918.00
*****	12/17/2025	706 G&J POWER EQUIPMENT INC	Check	No	82.55

ACCOUNTS PAYABLE CHECK REGISTER

Check Register for 12/4/2025 to 12/17/2025 & Check Numbers 0 to 2147483647

Cash Account 001-000-011

Check Number	Check Date	Vendor Number / Name	Payment Type	EPay	Amount (\$)
<i>Purchase Order #:</i> 0		<i>Voucher #:</i> 176041	<i>Invoice #:</i> 680808		82.55
<i>Invoice Description:</i>	EDGR RPR				
	001-210-618 RPR/MAINT EQUIPMENT			82.55	
***** 12/17/2025	723 GNG PLUMBING		Check	No	1,733.03
<i>Purchase Order #:</i> 0		<i>Voucher #:</i> 175599	<i>Invoice #:</i> 344049		76.85
<i>Invoice Description:</i>	PVC CMNT/ SHVL/ NUTDRVR SET				
	001-210-516 SUPPLIES/OPERATING			76.85	
<i>Purchase Order #:</i> 0		<i>Voucher #:</i> 175749	<i>Invoice #:</i> I-61219-1		244.75
<i>Invoice Description:</i>	GRNDR PMP CLN				
	001-410-652 STATE PARK EXPENSES			244.75	
<i>Purchase Order #:</i> 0		<i>Voucher #:</i> 175750	<i>Invoice #:</i> I-77784-1		630.01
<i>Invoice Description:</i>	PLMB RPR				
	001-410-616 RPR/MAINT PLANT/BLDGS			630.01	
<i>Purchase Order #:</i> 0		<i>Voucher #:</i> 175751	<i>Invoice #:</i> 343925		62.48
<i>Invoice Description:</i>	HOT WTR HS/ WSHR				
	001-609-728 GOLF COURSE			62.48	
<i>Purchase Order #:</i> 0		<i>Voucher #:</i> 175752	<i>Invoice #:</i> 343987		11.99
<i>Invoice Description:</i>	WTR PRSSR GAUGE				
	001-410-616 RPR/MAINT PLANT/BLDGS			11.99	
<i>Purchase Order #:</i> 0		<i>Voucher #:</i> 176042	<i>Invoice #:</i> I-77868-1		533.20
<i>Invoice Description:</i>	PLMBNG RPR				
	001-410-620 RPR/MAINT GROUNDS			533.20	
<i>Purchase Order #:</i> 0		<i>Voucher #:</i> 176043	<i>Invoice #:</i> 344039		14.46
<i>Invoice Description:</i>	PVC BLD/ CPLNGS				
	001-410-616 RPR/MAINT PLANT/BLDGS			14.46	
<i>Purchase Order #:</i> 0		<i>Voucher #:</i> 176044	<i>Invoice #:</i> 344065		16.67
<i>Invoice Description:</i>	HOSE BIBB/ BLL VLV/ ELBW				
	001-410-616 RPR/MAINT PLANT/BLDGS			16.67	
<i>Purchase Order #:</i> 0		<i>Voucher #:</i> 176045	<i>Invoice #:</i> 344085		22.34
<i>Invoice Description:</i>	CPLNGS/ ELBWS/ STRAPS				
	001-410-616 RPR/MAINT PLANT/BLDGS			22.34	
<i>Purchase Order #:</i> 0		<i>Voucher #:</i> 176046	<i>Invoice #:</i> 344099		54.90
<i>Invoice Description:</i>	PVC PIPES				
	001-410-616 RPR/MAINT PLANT/BLDGS			54.90	
<i>Purchase Order #:</i> 0		<i>Voucher #:</i> 176047	<i>Invoice #:</i> 344114		39.73
<i>Invoice Description:</i>	HOSE BIBB/ MEGALOC/ TEE/ ADPTR				
	001-410-616 RPR/MAINT PLANT/BLDGS			39.73	
<i>Purchase Order #:</i> 0		<i>Voucher #:</i> 176048	<i>Invoice #:</i> 344149		25.65
<i>Invoice Description:</i>	SILLCOCK/ TEE/ ADPTR				
	001-410-616 RPR/MAINT PLANT/BLDGS			25.65	
***** 12/17/2025	755 GRAINGER		Check	No	393.95
<i>Purchase Order #:</i> 0		<i>Voucher #:</i> 176049	<i>Invoice #:</i> 9716208278		393.95
<i>Invoice Description:</i>	BATTERY CHRGRS				
	403-676-616 RPR/MAINT PLANT/BLDGS			393.95	
***** 12/17/2025	8826 GRAY GASWORKS LLC		Check	No	875.00
<i>Purchase Order #:</i> 0		<i>Voucher #:</i> 175753	<i>Invoice #:</i> 3258		875.00
<i>Invoice Description:</i>	GAS LNTRN RPL				

ACCOUNTS PAYABLE CHECK REGISTER

Check Register for 12/4/2025 to 12/17/2025 & Check Numbers 0 to 2147483647

Cash Account 001-000-011

Check Number	Check Date	Vendor Number / Name	Payment Type	EPay	Amount (\$)
		430-682-616 RPR/MAINT PLANT/BLDGS		875.00	
*****	12/17/2025	8084 GREEN ELECTRIC	Check	No	9,490.00
		Purchase Order #: 0 Voucher #: 175754 Invoice #: 112625-12			2,490.00
		Invoice Description: MAN LFT RNTL			
		001-301-614 RENTALS		2,490.00	
		Purchase Order #: 0 Voucher #: 175755 Invoice #: 112625-13			2,400.00
		Invoice Description: FLD 8 LT RPR			
		001-301-618 RPR/MAINT EQUIPMENT		2,400.00	
		Purchase Order #: 0 Voucher #: 176050 Invoice #: 120325-13			2,400.00
		Invoice Description: MAN LFT RNT			
		001-301-614 RENTALS		2,400.00	
		Purchase Order #: 0 Voucher #: 176051 Invoice #: 120325-14			2,200.00
		Invoice Description: FLD 8 LT MNTC			
		001-301-618 RPR/MAINT EQUIPMENT		2,200.00	
*****	12/17/2025	7203 GREGORY T. HOFF	Check	No	178.77
		Purchase Order #: 0 Voucher #: 175872 Invoice #: 251130			178.77
		Invoice Description: NOV 2025			
		430-682-660 RESALE INV/ARTISTS		178.77	
*****	12/17/2025	5627 GULF COAST ORGANIC, INC	Check	No	90.88
		Purchase Order #: 0 Voucher #: 175756 Invoice #: 838			90.88
		Invoice Description: IR PIPE			
		001-303-620 RPR/MAINT GROUNDS		90.88	
*****	12/17/2025	3870 GULF SHORES EQUIPMENT RENTAL, LLC	Check	No	335.00
		Purchase Order #: 0 Voucher #: 176052 Invoice #: 2547-1			335.00
		Invoice Description: 11/21/25 SOD CTTR RNT			
		001-301-614 RENTALS		335.00	
*****	12/17/2025	792 GULF STATES DISTRIBUTORS	Check	No	265.00
		Purchase Order #: 0 Voucher #: 176053 Invoice #: 1499141-IN			95.00
		Invoice Description: SHOES			
		001-100-540 UNIFORMS		95.00	
		Purchase Order #: 0 Voucher #: 176054 Invoice #: 1499450-IN			170.00
		Invoice Description: PANTS			
		001-175-540 UNIFORMS		170.00	
*****	12/17/2025	6811 GYM-WORX, LLC	Check	No	396.87
		Purchase Order #: 0 Voucher #: 176055 Invoice #: I58859T1			396.87
		Invoice Description: EQPTMT RPR			
		001-325-618 RPR/MAINT EQUIPMENT		396.87	
*****	12/17/2025	6820 HARRIS LOCAL GOVERNMENT	Check	No	932.80
		Purchase Order #: 0 Voucher #: 175757 Invoice #: FORMXT005084			932.80
		Invoice Description: 1099/ W2 FORMS			
		001-020-516 SUPPLIES/OPERATING		932.80	
*****	12/17/2025	8865 HEIDI LEMON DBA HEIDI LEMON CHOREOGRAPHY	Check	No	2,218.00
		Purchase Order #: 0 Voucher #: 176056 Invoice #: 12012025			2,218.00
		Invoice Description: 'FRZN' 1 OF 2			

ACCOUNTS PAYABLE CHECK REGISTER

Check Register for 12/4/2025 to 12/17/2025 & Check Numbers 0 to 2147483647

Cash Account 001-000-011

Check Number	Check Date	Vendor Number / Name	Payment Type	EPay	Amount (\$)
		001-375-612 PROFESSIONAL FEES			2,218.00
*****	12/17/2025	1335 HENRY SCHEIN INC	Check	No	2,532.88
		Purchase Order #: 0 Voucher #: 175600 Invoice #: 49297583			76.80
		Invoice Description: EMS SPPLS			
		001-175-516 SUPPLIES/OPERATING			76.80
		Purchase Order #: 0 Voucher #: 175601 Invoice #: 49297582			1,044.07
		Invoice Description: EMS SPPLS			
		001-175-516 SUPPLIES/OPERATING			1,044.07
		Purchase Order #: 0 Voucher #: 175602 Invoice #: 49505163			125.73
		Invoice Description: EMS SPPLS			
		001-175-516 SUPPLIES/OPERATING			125.73
		Purchase Order #: 0 Voucher #: 175603 Invoice #: 49535011			66.70
		Invoice Description: EMS SPPLS			
		001-175-516 SUPPLIES/OPERATING			66.70
		Purchase Order #: 0 Voucher #: 176057 Invoice #: 49748686			1,219.58
		Invoice Description: EMS SPPLS			
		001-175-516 SUPPLIES/OPERATING			1,219.58
*****	12/17/2025	6551 HIGHWAY TRAFFIC SAFETY FUND	Check	No	60.00
		Purchase Order #: 0 Voucher #: 175853 Invoice #: 251201			60.00
		Invoice Description: NOV 2025			
		001-000-128 DUE COST FOR OTH AGENCIES			60.00
*****	12/17/2025	3579 HOBBY LOBBY	Check	No	294.31
		Purchase Order #: 0 Voucher #: 175758 Invoice #: 146010888			255.68
		Invoice Description: FALL DECOR/ OFC DECOR			
		001-300-516 SUPPLIES/OPERATING			255.68
		Purchase Order #: 0 Voucher #: 175759 Invoice #: 146281629			38.63
		Invoice Description: FLORAL/ EVENT DECOR			
		001-300-516 SUPPLIES/OPERATING			38.63
*****	12/17/2025	880 HUNTER SECURITY INC	Check	No	265.00
		Purchase Order #: 0 Voucher #: 176058 Invoice #: 1007680			265.00
		Invoice Description: DEC 2025			
		430-682-612 PROFESSIONAL FEES			80.00
		001-210-612 PROFESSIONAL FEES			55.00
		001-410-612 PROFESSIONAL FEES			130.00
*****	12/17/2025	7822 ICE PLANT, INC.	Check	No	783.00
		Purchase Order #: 0 Voucher #: 175604 Invoice #: 46-5920513			351.00
		Invoice Description: 234 BAGS ICE			
		001-200-516 SUPPLIES/OPERATING			117.00
		001-210-516 SUPPLIES/OPERATING			117.00
		404-677-516 SUPPLIES/OPERATING			117.00
		Purchase Order #: 0 Voucher #: 175760 Invoice #: 35-5831992			108.00
		Invoice Description: 72 BAGS ICE			
		001-210-516 SUPPLIES/OPERATING			108.00
		Purchase Order #: 0 Voucher #: 176059 Invoice #: 46-5920552			324.00
		Invoice Description: 216 BAGS ICE			
		001-200-516 SUPPLIES/OPERATING			108.00

ACCOUNTS PAYABLE CHECK REGISTER

Check Register for 12/4/2025 to 12/17/2025 & Check Numbers 0 to 2147483647

Cash Account 001-000-011

Check Number	Check Date	Vendor Number / Name	Payment Type	EPay	Amount (\$)
		001-210-516 SUPPLIES/OPERATING			108.00
		404-677-516 SUPPLIES/OPERATING			108.00
****	12/17/2025	230 IMPERIAL DADE	Check	No	1,827.50
		Purchase Order #: 0 Voucher #: 175761 Invoice #: 39825678			1,827.50
		Invoice Description: DSINF WPS/ P-TWLS/ T-TISS			
		001-325-513 SUPPLIES/JANITORIAL			1,827.50
****	12/17/2025	6419 INTEGRATED POWER SERVICES	Check	No	2,443.98
		Purchase Order #: 0 Voucher #: 175605 Invoice #: 26343118			200.00
		Invoice Description: MINOR PM MNT GNRTR			
		001-030-618 RPR/MAINT EQUIPMENT			200.00
		Purchase Order #: 0 Voucher #: 175606 Invoice #: 26343119			200.00
		Invoice Description: MINOR PM MNT GNRTR			
		001-100-620 RPR/MAINT GROUNDS			200.00
		Purchase Order #: 0 Voucher #: 175607 Invoice #: 26343244			200.00
		Invoice Description: ADMN MINOR PM MNT GNRTR			
		001-175-616 RPR/MAINT PLANT/BLDGS			200.00
		Purchase Order #: 0 Voucher #: 175608 Invoice #: 26343245			200.00
		Invoice Description: STN 1 MINOR PM MNT GNRTR			
		001-175-616 RPR/MAINT PLANT/BLDGS			200.00
		Purchase Order #: 0 Voucher #: 175762 Invoice #: 26343246			200.00
		Invoice Description: BCH BRN MINOR PM MNT GNRTR			
		001-410-618 RPR/MAINT EQUIPMENT			200.00
		Purchase Order #: 0 Voucher #: 176060 Invoice #: 26343243			200.00
		Invoice Description: MINOR PM GNRTR			
		001-001-616 RPR/MAINT PLANT/BLDGS			200.00
		Purchase Order #: 0 Voucher #: 176061 Invoice #: 26343288			200.00
		Invoice Description: MINOR PM GNRTR			
		411-681-618 RPR/MAINT EQUIPMENT			200.00
		Purchase Order #: 0 Voucher #: 176062 Invoice #: 26343289			200.00
		Invoice Description: MINOR PM GNRTR			
		001-350-612 PROFESSIONAL FEES			200.00
		Purchase Order #: 0 Voucher #: 176063 Invoice #: 26343290			200.00
		Invoice Description: MINOR PM GNRTR			
		404-677-612 PROFESSIONAL FEES			200.00
		Purchase Order #: 0 Voucher #: 176064 Invoice #: 26343291			200.00
		Invoice Description: STN 2 MINOR PM GNRTR			
		001-175-616 RPR/MAINT PLANT/BLDGS			200.00
		Purchase Order #: 0 Voucher #: 176065 Invoice #: 26343292			200.00
		Invoice Description: STN 3 MINOR PM GNRTR			
		001-175-616 RPR/MAINT PLANT/BLDGS			200.00
		Purchase Order #: 0 Voucher #: 176066 Invoice #: 26343756			243.98
		Invoice Description: BCH BRN MINOR PM GNRTR			
		001-410-616 RPR/MAINT PLANT/BLDGS			243.98
****	12/17/2025	7523 INTERNAL REVENUE SERVICE	Check	No	150.00
		Purchase Order #: 0 Voucher #: 176067 Invoice #: 112825-BURKHART			150.00
		Invoice Description: XX-0052			
		001-000-104 GARNISHMENT/SAVINGS			150.00

ACCOUNTS PAYABLE CHECK REGISTER

Check Register for 12/4/2025 to 12/17/2025 & Check Numbers 0 to 2147483647

Cash Account 001-000-011

Check Number	Check Date	Vendor Number / Name	Payment Type	EPay	Amount (\$)
*****	12/17/2025	940 INTERSTATE PRINTING & GRAPHICS INC	Check	No	92.00
		Purchase Order #: 0 Voucher #: 175609 Invoice #: 45474			46.00
		Invoice Description: W CHINAL BZ CRDS			
		001-100-612 PROFESSIONAL FEES			46.00
		Purchase Order #: 0 Voucher #: 175763 Invoice #: 45469			46.00
		Invoice Description: P ELLISON BZ CRDS			
		001-410-612 PROFESSIONAL FEES			46.00
*****	12/17/2025	8292 JACK SWINDLE	Check	No	388.07
		Purchase Order #: 0 Voucher #: 175873 Invoice #: 251130			388.07
		Invoice Description: NOV 2025			
		430-682-660 RESALE INV/ARTISTS			388.07
*****	12/17/2025	6543 JANE SIMS	Check	No	420.00
		Purchase Order #: 0 Voucher #: 175673 Invoice #: 251121			330.00
		Invoice Description: PIYO/ INDR CYCL/ HIIT/ PILATES			
		001-325-612 PROFESSIONAL FEES			330.00
		Purchase Order #: 0 Voucher #: 175674 Invoice #: 251126			90.00
		Invoice Description: PIYO/ P90X/ INDR CYCL			
		001-325-612 PROFESSIONAL FEES			90.00
*****	12/17/2025	3394 JASPER ENGINES & TRANSMISSIONS	Check	No	3,815.00
		Purchase Order #: 250570 Voucher #: 176068 Invoice #: 15181659			3,815.00
		Invoice Description: #904 TRNSMSSN RPL			
		404-677-622 RPR/MAINT VEHICLES			3,815.00
*****	12/17/2025	8886 JEREMIAH REAGAN	Check	No	450.00
		Purchase Order #: 0 Voucher #: 176069 Invoice #: 251124			450.00
		Invoice Description: RMB EMPL UNIFRMS			
		001-100-540 UNIFORMS			450.00
*****	12/17/2025	1033 JERRY PATE TURF & IRRIGATION	Check	No	13,971.89
		Purchase Order #: 250531 Voucher #: 176071 Invoice #: 642940			13,971.89
		Invoice Description: CARRYALL GLFCRT			
		001-210-507 EQUIPMENT/SMALL			13,971.89
*****	12/17/2025	7417 J. HIGGINS LTD., INC	Check	No	457.00
		Purchase Order #: 0 Voucher #: 176070 Invoice #: 198892			457.00
		Invoice Description: PANT TRIM			
		001-110-540 UNIFORMS			457.00
*****	12/17/2025	8027 JILL TAYLOR	Check	No	180.00
		Purchase Order #: 0 Voucher #: 175675 Invoice #: 251121			60.00
		Invoice Description: YOGA			
		001-325-612 PROFESSIONAL FEES			60.00
		Purchase Order #: 0 Voucher #: 175676 Invoice #: 251126			30.00
		Invoice Description: YOGA			
		001-325-612 PROFESSIONAL FEES			30.00
		Purchase Order #: 0 Voucher #: 175764 Invoice #: 251120			60.00
		Invoice Description: YOGA			
		001-304-612 PROFESSIONAL FEES			60.00
		Purchase Order #: 0 Voucher #: 175765 Invoice #: 251201			30.00

ACCOUNTS PAYABLE CHECK REGISTER

Check Register for 12/4/2025 to 12/17/2025 & Check Numbers 0 to 2147483647

Cash Account 001-000-011

Check Number	Check Date	Vendor Number / Name	Payment Type	EPay	Amount (\$)
		<i>Invoice Description:</i> YOGA			
		001-304-612 PROFESSIONAL FEES			30.00
*****	12/17/2025	871 JIM HOUSE & ASSOCIATES	Check	No	270.00
	<i>Purchase Order #:</i> 0	<i>Voucher #:</i> 176072	<i>Invoice #:</i> 25818		270.00
		<i>Invoice Description:</i> OIL LVL GAUGES			
		403-676-616 RPR/MAINT PLANT/BLDGS			270.00
*****	12/17/2025	3302 J & M TACKLE	Check	No	10.50
	<i>Purchase Order #:</i> 0	<i>Voucher #:</i> 175766	<i>Invoice #:</i> 2350928		10.50
		<i>Invoice Description:</i> MINNOWS			
		001-410-516 SUPPLIES/OPERATING			10.50
*****	12/17/2025	8310 JOAN G. HILL	Check	No	60.00
	<i>Purchase Order #:</i> 0	<i>Voucher #:</i> 176073	<i>Invoice #:</i> 119		60.00
		<i>Invoice Description:</i> 11/17-11/21/25 WTR FTNSS			
		001-302-612 PROFESSIONAL FEES			60.00
*****	12/17/2025	5100 JOHN B GAMBLE, PC	Check	No	374.00
	<i>Purchase Order #:</i> 0	<i>Voucher #:</i> 175610	<i>Invoice #:</i> MC2025-404		121.00
		<i>Invoice Description:</i> B. SASSER			
		001-010-612 PROFESSIONAL FEES			121.00
	<i>Purchase Order #:</i> 0	<i>Voucher #:</i> 175611	<i>Invoice #:</i> TR2025-863		253.00
		<i>Invoice Description:</i> J. SCHNIEBLE			
		001-010-612 PROFESSIONAL FEES			253.00
*****	12/17/2025	8580 JOHN ROACH LAW, LLC	Check	No	495.00
	<i>Purchase Order #:</i> 0	<i>Voucher #:</i> 175612	<i>Invoice #:</i> MC2020-0039		181.50
		<i>Invoice Description:</i> J. RYE			
		001-010-612 PROFESSIONAL FEES			181.50
	<i>Purchase Order #:</i> 0	<i>Voucher #:</i> 175613	<i>Invoice #:</i> TR2025-0935		313.50
		<i>Invoice Description:</i> J. MASSIE			
		001-010-612 PROFESSIONAL FEES			313.50
*****	12/17/2025	6025 JOHN'S STAINED GLASS	Check	No	260.02
	<i>Purchase Order #:</i> 0	<i>Voucher #:</i> 175874	<i>Invoice #:</i> 251130		260.02
		<i>Invoice Description:</i> NOV 2025			
		430-682-660 RESALE INV/ARTISTS			260.02
*****	12/17/2025	8751 KAREN L. MALATESTA	Check	No	60.00
	<i>Purchase Order #:</i> 0	<i>Voucher #:</i> 175677	<i>Invoice #:</i> 251126		60.00
		<i>Invoice Description:</i> YOGA/ PILATES			
		001-325-612 PROFESSIONAL FEES			60.00
*****	12/17/2025	6102 KERRY PARKS	Check	No	1,907.78
	<i>Purchase Order #:</i> 0	<i>Voucher #:</i> 175875	<i>Invoice #:</i> 251130		1,907.78
		<i>Invoice Description:</i> NOV 2025			
		430-682-660 RESALE INV/ARTISTS			1,907.78
*****	12/17/2025	5089 KIMBALL MIDWEST	Check	No	218.55
	<i>Purchase Order #:</i> 0	<i>Voucher #:</i> 176074	<i>Invoice #:</i> 103941221		218.55
		<i>Invoice Description:</i> STK BUTT CNNCTRS/ RNG TRMS			
		001-210-516 SUPPLIES/OPERATING			218.55

ACCOUNTS PAYABLE CHECK REGISTER

Check Register for 12/4/2025 to 12/17/2025 & Check Numbers 0 to 2147483647

Cash Account 001-000-011

Check Number	Check Date	Vendor Number / Name	Payment Type	EPay	Amount (\$)
*****	12/17/2025	7047 KNOX PEST CONTROL	Check	No	549.00
		Purchase Order #: 0 Voucher #: 175614 Invoice #: 573315			30.00
		Invoice Description: COMM DEV			
		001-030-616 RPR/MAINT PLANT/BLDG			30.00
		Purchase Order #: 0 Voucher #: 175767 Invoice #: 549904			28.00
		Invoice Description: ARTS CTR			
		430-682-612 PROFESSIONAL FEES			28.00
		Purchase Order #: 0 Voucher #: 175768 Invoice #: 573010			28.00
		Invoice Description: CR OFC			
		001-410-616 RPR/MAINT PLANT/BLDGS			28.00
		Purchase Order #: 0 Voucher #: 175769 Invoice #: 573012			28.00
		Invoice Description: FINANCE OFC			
		001-020-616 RPR/MAINT PLANT/BLDGS			28.00
		Purchase Order #: 0 Voucher #: 175770 Invoice #: 573322			42.00
		Invoice Description: SPORTSPLEX			
		001-301-616 RPR/MAINT PLANT/BLDGS			42.00
		Purchase Order #: 0 Voucher #: 175771 Invoice #: 573764			28.00
		Invoice Description: BEACH BARN			
		001-410-616 RPR/MAINT PLANT/BLDGS			28.00
		Purchase Order #: 0 Voucher #: 175772 Invoice #: 573784			28.00
		Invoice Description: INTERN HOUSE			
		001-410-616 RPR/MAINT PLANT/BLDGS			28.00
		Purchase Order #: 0 Voucher #: 175773 Invoice #: 573793			28.00
		Invoice Description: WILDLIFE CTR			
		001-410-616 RPR/MAINT PLANT/BLDGS			28.00
		Purchase Order #: 0 Voucher #: 176075 Invoice #: 573013			30.00
		Invoice Description: GOLF CTR ALL BLDGS			
		001-303-616 RPR/MAINT PLANT/BLDGS			30.00
		Purchase Order #: 0 Voucher #: 176076 Invoice #: 573016			28.00
		Invoice Description: PW BLDG			
		001-210-612 PROFESSIONAL FEES			28.00
		Purchase Order #: 0 Voucher #: 176077 Invoice #: 573308			42.00
		Invoice Description: CITY HALL			
		001-001-616 RPR/MAINT PLANT/BLDGS			42.00
		Purchase Order #: 0 Voucher #: 176078 Invoice #: 573314			28.00
		Invoice Description: COMM CTR			
		411-681-620 RPR/MAINT GROUNDS			28.00
		Purchase Order #: 0 Voucher #: 176079 Invoice #: 573316			36.00
		Invoice Description: EVENT CTR			
		411-681-620 RPR/MAINT GROUNDS			36.00
		Purchase Order #: 0 Voucher #: 176080 Invoice #: 573318			36.00
		Invoice Description: MED ARTS CTR			
		001-001-616 RPR/MAINT PLANT/BLDGS			36.00
		Purchase Order #: 0 Voucher #: 176081 Invoice #: 573319			32.00
		Invoice Description: MUSEUM			
		001-300-616 RPR/MAINT PLANT/BLDGS			32.00
		Purchase Order #: 0 Voucher #: 176082 Invoice #: 573763			38.00
		Invoice Description: SKEET HSES			

ACCOUNTS PAYABLE CHECK REGISTER

Check Register for 12/4/2025 to 12/17/2025 & Check Numbers 0 to 2147483647

Cash Account 001-000-011

Check Number	Check Date	Vendor Number / Name	Payment Type	EPay	Amount (\$)
		001-410-620 RPR/MAINT GROUNDS			38.00
		Purchase Order #: 0 Voucher #: 176083 Invoice #: 573814			39.00
		Invoice Description: GOLF RODENT CNTL			
		001-303-616 RPR/MAINT PLANT/BLDGS			39.00
*****	12/17/2025	6916 KONE INC	Check	No	285.00
		Purchase Order #: 0 Voucher #: 176084 Invoice #: 871877917			285.00
		Invoice Description: DEC 2025			
		430-682-612 PROFESSIONAL FEES			285.00
*****	12/17/2025	7736 K. PIERRE LLC	Check	No	568.75
		Purchase Order #: 0 Voucher #: 175876 Invoice #: 251130			568.75
		Invoice Description: NOV 2025			
		430-682-660 RESALE INV/ARTISTS			568.75
*****	12/17/2025	8622 LANIER FORD SHAVER & PAYNE P.C.	Check	No	126.00
		Purchase Order #: 0 Voucher #: 176085 Invoice #: 267413			126.00
		Invoice Description: HR LEGAL CONSLTNT			
		001-001-612 PROFESSIONAL FEES			126.00
*****	12/17/2025	8723 LAUREN A. PROSSER	Check	No	60.00
		Purchase Order #: 0 Voucher #: 175678 Invoice #: 251121			60.00
		Invoice Description: INDR CYCL			
		001-325-612 PROFESSIONAL FEES			60.00
*****	12/17/2025	8057 LAUREN C. McCAGHREN	Check	No	90.00
		Purchase Order #: 0 Voucher #: 175679 Invoice #: 251121			60.00
		Invoice Description: CRDO DNC			
		001-325-612 PROFESSIONAL FEES			60.00
		Purchase Order #: 0 Voucher #: 175680 Invoice #: 251126			30.00
		Invoice Description: CRDO DNC			
		001-325-612 PROFESSIONAL FEES			30.00
*****	12/17/2025	5305 LAZZARI TRUCK REPAIR, INC.	Check	No	18,030.19
		Purchase Order #: 0 Voucher #: 176086 Invoice #: W46775			1,102.96
		Invoice Description: #952 FL FLTR RPL/ HYDRYLC PM			
		001-200-618 RPR/MAINT EQUIPMENT			1,102.96
		Purchase Order #: 0 Voucher #: 176087 Invoice #: W46776			1,108.35
		Invoice Description: #718 HYDRYLC PM/ FL FLTR RPL			
		001-200-618 RPR/MAINT EQUIPMENT			1,108.35
		Purchase Order #: 0 Voucher #: 176088 Invoice #: W46778			1,027.89
		Invoice Description: #712 HYDRLC PM/ FLTRS			
		001-200-618 RPR/MAINT EQUIPMENT			1,027.89
		Purchase Order #: 0 Voucher #: 176089 Invoice #: W46780			302.64
		Invoice Description: #796 FLTRS			
		001-200-622 RPR/MAINT VEHICLES			302.64
		Purchase Order #: 0 Voucher #: 176090 Invoice #: W46782			1,681.74
		Invoice Description: #906 HYDRLC SVC/ TRNSMSSN SVC			
		404-677-622 RPR/MAINT VEHICLES			1,681.74
		Purchase Order #: 0 Voucher #: 176091 Invoice #: W46783			1,522.85
		Invoice Description: #903 HYDRLC SVC/ TRNSMSSN SVC			

ACCOUNTS PAYABLE CHECK REGISTER

Check Register for 12/4/2025 to 12/17/2025 & Check Numbers 0 to 2147483647

Cash Account 001-000-011

Check Number	Check Date	Vendor Number / Name	Payment Type	EPay	Amount (\$)
		404-677-622 RPR/MAINT VEHICLES			1,522.85
		Purchase Order #: 0 Voucher #: 176092 Invoice #: W46784			1,657.37
		Invoice Description: #901 HYDRLC SVC/ TRNSMSSN SVC			
		404-677-622 RPR/MAINT VEHICLES			1,657.37
		Purchase Order #: 0 Voucher #: 176093 Invoice #: W46785			1,681.74
		Invoice Description: #902 HYDRLC SVC/ TRNSMSSN SVC			
		404-677-622 RPR/MAINT VEHICLES			1,681.74
		Purchase Order #: 0 Voucher #: 176094 Invoice #: W46786			1,667.40
		Invoice Description: #709 HYDRLC SVC/ TRNSMSSN SVC			
		404-677-622 RPR/MAINT VEHICLES			1,667.40
		Purchase Order #: 0 Voucher #: 176095 Invoice #: W46787			1,038.36
		Invoice Description: #702 TRNSMSSN SVC/ FLTRS			
		001-200-618 RPR/MAINT EQUIPMENT			1,038.36
		Purchase Order #: 0 Voucher #: 176096 Invoice #: W46796			1,959.67
		Invoice Description: #411 TRNSMSSN SVC			
		001-175-622 RPR/MAINT VEHICLES			1,959.67
		Purchase Order #: 0 Voucher #: 176097 Invoice #: W16855			1,046.16
		Invoice Description: #796 RD CLL/ BLT TNSNR RPR			
		001-200-622 RPR/MAINT VEHICLES			1,046.16
		Purchase Order #: 0 Voucher #: 176098 Invoice #: W46898			890.99
		Invoice Description: #907 HYDRLC SVC/ FLTRS			
		404-677-622 RPR/MAINT VEHICLES			890.99
		Purchase Order #: 0 Voucher #: 176099 Invoice #: W46899			1,342.07
		Invoice Description: #747 HYDRLC SVC/ FLTRS			
		001-200-618 RPR/MAINT EQUIPMENT			1,342.07
*****	12/17/2025	1234 LIBERTY LINEN	Check	No	690.20
		Purchase Order #: 0 Voucher #: 175615 Invoice #: 226261			55.34
		Invoice Description: DST PAN/ MOP HNDL/ BRM			
		001-110-513 SUPPLIES/JANITORIAL			55.34
		Purchase Order #: 0 Voucher #: 175616 Invoice #: 226289			82.21
		Invoice Description: LAUNDRY DET			
		001-110-516 SUPPLIES/OPERATING			82.21
		Purchase Order #: 0 Voucher #: 175774 Invoice #: 225672			37.64
		Invoice Description: P-TWLS			
		430-682-513 SUPPLIES/JANITORIAL			37.64
		Purchase Order #: 0 Voucher #: 175775 Invoice #: 226266			27.63
		Invoice Description: P-TWLS			
		430-682-513 SUPPLIES/JANITORIAL			27.63
		Purchase Order #: 0 Voucher #: 175776 Invoice #: 226335			140.94
		Invoice Description: GLVS/ P-TWLS			
		001-410-513 SUPPLIES/JANITORIAL			140.94
		Purchase Order #: 0 Voucher #: 176100 Invoice #: 226296			134.47
		Invoice Description: RUG			
		001-001-616 RPR/MAINT PLANT/BLDGS			134.47
		Purchase Order #: 0 Voucher #: 176101 Invoice #: 226399			211.97
		Invoice Description: CAN LNRS/ DEGRSR/ BLCH			
		001-175-513 SUPPLIES/JANITORIAL			211.97

ACCOUNTS PAYABLE CHECK REGISTER

Check Register for 12/4/2025 to 12/17/2025 & Check Numbers 0 to 2147483647

Cash Account 001-000-011

Check Number	Check Date	Vendor Number / Name	Payment Type	EPay	Amount (\$)
****	12/17/2025	8066 LIMITLESS SERVICES	Check	No	23,704.00
	<i>Purchase Order #:</i> 250102	<i>Voucher #:</i> 176102	<i>Invoice #:</i> QB1195		7,930.00
	<i>Invoice Description:</i> SEPT 25 LNDSCP CNSLT				
	001-301-612	PROFESSIONAL FEES		7,930.00	
	<i>Purchase Order #:</i> 250102	<i>Voucher #:</i> 176103	<i>Invoice #:</i> QB1196		15,774.00
	<i>Invoice Description:</i> OCT 25 LNDSCP CNSLT				
	001-301-612	PROFESSIONAL FEES		15,774.00	
****	12/17/2025	7354 LINCOLN NATIONAL LIFE INSURANCE COMPANY	Check	No	2,401.64
	<i>Purchase Order #:</i> 0	<i>Voucher #:</i> 175617	<i>Invoice #:</i> 251001		1,198.02
	<i>Invoice Description:</i> OCT 2025				
	001-001-480	INSURANCE/HEALTH		44.56	
	001-010-480	INSURANCE/HEALTH		11.70	
	001-020-480	INSURANCE/HEALTH		28.96	
	001-030-480	INSURANCE/HEALTH		46.32	
	001-100-480	INSURANCE/HEALTH		211.32	
	001-110-480	INSURANCE/HEALTH		34.60	
	001-120-480	INSURANCE/HEALTH		24.40	
	001-175-480	INSURANCE/HEALTH		250.50	
	001-200-480	INSURANCE/HEALTH		114.48	
	001-210-480	INSURANCE/HEALTH		48.60	
	001-300-480	INSURANCE/HEALTH		11.70	
	001-301-480	INSURANCE/HEALTH		34.60	
	001-302-480	INSURANCE/HEALTH		8.90	
	001-303-480	INSURANCE/HEALTH		26.20	
	001-304-480	INSURANCE/HEALTH		5.60	
	001-325-480	INSURANCE/HEALTH		19.60	
	001-350-480	INSURANCE/HEALTH		57.50	
	001-410-480	INSURANCE/HEALTH		68.40	
	403-676-480	INSURANCE/HEALTH		75.52	
	404-677-480	INSURANCE/HEALTH		27.22	
	411-681-480	INSURANCE/HEALTH		16.00	
	430-682-480	INSURANCE/HEALTH		31.34	
	<i>Purchase Order #:</i> 0	<i>Voucher #:</i> 175618	<i>Invoice #:</i> 251101		1,203.62
	<i>Invoice Description:</i> NOV 2025				
	001-001-480	INSURANCE/HEALTH		44.56	
	001-010-480	INSURANCE/HEALTH		11.70	
	001-020-480	INSURANCE/HEALTH		28.96	
	001-030-480	INSURANCE/HEALTH		46.32	
	001-100-480	INSURANCE/HEALTH		211.32	
	001-110-480	INSURANCE/HEALTH		34.60	
	001-120-480	INSURANCE/HEALTH		24.40	
	001-175-480	INSURANCE/HEALTH		250.50	
	001-200-480	INSURANCE/HEALTH		114.48	
	001-210-480	INSURANCE/HEALTH		48.60	
	001-300-480	INSURANCE/HEALTH		11.70	

ACCOUNTS PAYABLE CHECK REGISTER

Check Register for 12/4/2025 to 12/17/2025 & Check Numbers 0 to 2147483647

Cash Account 001-000-011

Check Number	Check Date	Vendor Number / Name	Payment Type	EPay	Amount (\$)
	001-301-480	INSURANCE/HEALTH			37.40
	001-302-480	INSURANCE/HEALTH			8.90
	001-303-480	INSURANCE/HEALTH			26.20
	001-304-480	INSURANCE/HEALTH			5.60
	001-325-480	INSURANCE/HEALTH			19.60
	001-350-480	INSURANCE/HEALTH			57.50
	001-410-480	INSURANCE/HEALTH			68.40
	403-676-480	INSURANCE/HEALTH			78.32
	404-677-480	INSURANCE/HEALTH			27.22
	411-681-480	INSURANCE/HEALTH			16.00
	430-682-480	INSURANCE/HEALTH			31.34
****	12/17/2025	6685 LINDA BELL SCHORER	Check	No	126.75
	Purchase Order #: 0	Voucher #: 175877	Invoice #: 251130		126.75
	Invoice Description: NOV 2025				
	430-682-660	RESALE INV/ARTISTS			126.75
****	12/17/2025	7860 LISA R. NIX	Check	No	30.00
	Purchase Order #: 0	Voucher #: 175681	Invoice #: 251126		30.00
	Invoice Description: TBF				
	001-325-612	PROFESSIONAL FEES			30.00
****	12/17/2025	8177 LONNIE HODGE	Check	No	51.35
	Purchase Order #: 0	Voucher #: 175878	Invoice #: 251130		51.35
	Invoice Description: NOV 2025				
	430-682-660	RESALE INV/ARTISTS			51.35
****	12/17/2025	8699 LOWE'S PRO SUPPLY	Check	No	2,838.19
	Purchase Order #: 0	Voucher #: 175619	Invoice #: 19467863-00		82.43
	Invoice Description: NAILS/ CONST ADHSV/ PWR STRP				
	001-350-616	RPR/MAINT PLANT/BLDGS			82.43
	Purchase Order #: 0	Voucher #: 175620	Invoice #: 19469042-00		690.54
	Invoice Description: TOOL BTTRIES/ TOOL KIT/ SAW BLDS				
	001-200-516	SUPPLIES/OPERATING			690.54
	Purchase Order #: 0	Voucher #: 175621	Invoice #: 19475103-00		354.25
	Invoice Description: FRM NAILER				
	001-200-507	EQUIPMENT/SMALL			354.25
	Purchase Order #: 0	Voucher #: 175622	Invoice #: 19475116-00		322.05
	Invoice Description: FRM NAILER				
	001-200-507	EQUIPMENT/SMALL			322.05
	Purchase Order #: 0	Voucher #: 175623	Invoice #: 19476815-00		-354.25
	Invoice Description: CRDT- FRM NLR				
	001-200-507	EQUIPMENT/SMALL			-354.25
	Purchase Order #: 0	Voucher #: 175777	Invoice #: 19467872-00		59.30
	Invoice Description: HINGES/ LMBR/ DRLL BIT				
	001-410-616	RPR/MAINT PLANT/BLDGS			59.30
	Purchase Order #: 0	Voucher #: 176104	Invoice #: 19320358-00		59.38
	Invoice Description: QKRETE/ LMBR				
	430-682-620	RPR/MAINT GROUNDS			59.38
	Purchase Order #: 0	Voucher #: 176105	Invoice #: 19431579-00		528.00

ACCOUNTS PAYABLE CHECK REGISTER

Check Register for 12/4/2025 to 12/17/2025 & Check Numbers 0 to 2147483647

Cash Account 001-000-011

Check Number	Check Date	Vendor Number / Name	Payment Type	EPay	Amount (\$)
		Invoice Description: PADLOCKS			
		001-301-516 SUPPLIES/OPERATING		528.00	
		Purchase Order #: 0 Voucher #: 176106 Invoice #: 19432107-00			-528.00
		Invoice Description: CRDT PADLOCKS			
		001-301-516 SUPPLIES/OPERATING		-528.00	
		Purchase Order #: 0 Voucher #: 176107 Invoice #: 19477570-00			284.99
		Invoice Description: ICE MKR			
		001-350-507 EQUIPMENT/SMALL		284.99	
		Purchase Order #: 0 Voucher #: 176108 Invoice #: 19485696-00			189.05
		Invoice Description: WELL TANK			
		001-410-652 STATE PARK EXPENSES		189.05	
		Purchase Order #: 0 Voucher #: 176109 Invoice #: 19491683-00			83.40
		Invoice Description: LMBR			
		001-350-516 SUPPLIES/OPERATING		83.40	
		Purchase Order #: 0 Voucher #: 176110 Invoice #: 19491705-00			251.43
		Invoice Description: 'VSNS' LBBY DECOR			
		001-375-636 PRODUCTION COST		251.43	
		Purchase Order #: 0 Voucher #: 176111 Invoice #: 19509631-00			114.51
		Invoice Description: ELEC WR/ PIC HNG STRPS			
		403-676-516 SUPPLIES/OPERATING		114.51	
		Purchase Order #: 0 Voucher #: 176112 Invoice #: 19516434-00			62.40
		Invoice Description: ELEC WR			
		403-676-516 SUPPLIES/OPERATING		62.40	
		Purchase Order #: 0 Voucher #: 176113 Invoice #: 19516437-00			583.62
		Invoice Description: 'FRZN' SHTHNG/ 'VSNS' DECOR			
		001-375-516 SUPPLIES/OPERATING		106.13	
		001-375-636 PRODUCTION COST		156.63	
		001-375-636 PRODUCTION COST		320.86	
		Purchase Order #: 0 Voucher #: 176114 Invoice #: 19519612-00			55.09
		Invoice Description: TBL LEGS			
		001-350-507 EQUIPMENT/SMALL		55.09	
*****	12/17/2025	8764 MADISON CTY COURT CLERK	Check	No	217.50
		Purchase Order #: 0 Voucher #: 176115 Invoice #: 112825-CLARK			217.50
		Invoice Description: 47-SM-2024-901908.00			
		001-000-104 GARNISHMENT/SAVINGS		217.50	
*****	12/17/2025	7710 MARQUISE B. ELSTON	Check	No	240.00
		Purchase Order #: 0 Voucher #: 175682 Invoice #: 251121			150.00
		Invoice Description: TBF			
		001-325-612 PROFFESIONAL FEES		150.00	
		Purchase Order #: 0 Voucher #: 175683 Invoice #: 251126			90.00
		Invoice Description: TBF			
		001-325-612 PROFFESIONAL FEES		90.00	
*****	12/17/2025	5567 MARY A. BROWN	Check	No	23.40
		Purchase Order #: 0 Voucher #: 175879 Invoice #: 251130			23.40
		Invoice Description: NOV 2025			
		430-682-660 RESALE INV/ARTISTS		23.40	

ACCOUNTS PAYABLE CHECK REGISTER

Check Register for 12/4/2025 to 12/17/2025 & Check Numbers 0 to 2147483647

Cash Account 001-000-011

Check Number	Check Date	Vendor Number / Name	Payment Type	EPay	Amount (\$)
****	12/17/2025	4079 MARY JOE CARTER	Check	No	79.49
		Purchase Order #: 0 Voucher #: 175880 Invoice #: 251130			79.49
		Invoice Description: NOV 2025			
		430-682-660 RESALE INVI/ARTISTS			79.49
****	12/17/2025	1320 MATHES OF ALABAMA ELECTRIC SUPPLY CO	Check	No	248.67
		Purchase Order #: 0 Voucher #: 176116 Invoice #: S100044034.001			248.67
		Invoice Description: NO DISC TIMER/ TWSTRS/ CVR			
		001-001-616 RPR/MAINT PLANT/BLDGS			248.67
****	12/17/2025	5190 MAYA BLUME-CANTRELL	Check	No	521.97
		Purchase Order #: 0 Voucher #: 175881 Invoice #: 251130			521.97
		Invoice Description: NOV 2025			
		430-682-660 RESALE INVI/ARTISTS			521.97
****	12/17/2025	3667 McCOLLOUGH ARCHITECTURE, INC.	Check	No	800.00
		Purchase Order #: 0 Voucher #: 176117 Invoice #: 5815			800.00
		Invoice Description: FIRE TRN BLDG 1 OF 8			
		001-607-710 FIRE STATION RENOVATION			800.00
****	12/17/2025	7613 MCCOY FIRE & SAFETY, INC	Check	No	460.00
		Purchase Order #: 0 Voucher #: 176118 Invoice #: 12481270			460.00
		Invoice Description: SPRNKLR RPR			
		001-350-616 RPR/MAINT PLANT/BLDGS			460.00
****	12/17/2025	7151 MES SERVICES COMPANY, LLC	Check	No	259.32
		Purchase Order #: 0 Voucher #: 176119 Invoice #: IN2387642			259.32
		Invoice Description: CLLR INSGNIA			
		001-175-540 UNIFORMS			259.32
****	12/17/2025	7132 MICHELLE MURPHY	Check	No	280.00
		Purchase Order #: 0 Voucher #: 175684 Invoice #: 251121			160.00
		Invoice Description: ZUMBA/ SHINE			
		001-325-612 PROFESSIONAL FEES			160.00
		Purchase Order #: 0 Voucher #: 175685 Invoice #: 251126			120.00
		Invoice Description: ZUMBA			
		001-325-612 PROFESSIONAL FEES			120.00
****	12/17/2025	6956 MIDWAY LUMBER SALES INC	Check	No	1,510.00
		Purchase Order #: 0 Voucher #: 176120 Invoice #: 107275			1,510.00
		Invoice Description: FENCE POSTS			
		001-410-650 AUDUBON			1,510.00
****	12/17/2025	8508 MIDWEST VETERINARY SUPPLY, INC.	Check	No	96.21
		Purchase Order #: 0 Voucher #: 175778 Invoice #: 26995169-000			96.21
		Invoice Description: WLDLF MED SPPLS			
		001-410-612 PROFESSIONAL FEES			96.21
****	12/17/2025	8766 NATALIE J. VAN BLERK	Check	No	1,330.00
		Purchase Order #: 0 Voucher #: 176121 Invoice #: 251126			1,330.00
		Invoice Description: NOV 2025 DRILLS			
		001-325-612 PROFESSIONAL FEES			1,330.00

ACCOUNTS PAYABLE CHECK REGISTER

Check Register for 12/4/2025 to 12/17/2025 & Check Numbers 0 to 2147483647

Cash Account 001-000-011

Check Number	Check Date	Vendor Number / Name	Payment Type	EPay	Amount (\$)
*****	12/17/2025	8302 NIGHT FLYER GOLF	Check	No	1,792.00
		Purchase Order #: 0 Voucher #: 176255 Invoice #: 06415			1,792.00
		Invoice Description: GLO-IN-DRK BALLS			
		001-303-516 SUPPLIES/OPERATING			1,792.00
*****	12/17/2025	1515 ODP OFFICE SOLUTIONS, LLC	Check	No	582.19
		Purchase Order #: 0 Voucher #: 176122 Invoice #: 448958831001			223.92
		Invoice Description: INK/ COPY PPR/ PST-IT NTS			
		001-303-516 SUPPLIES/OPERATING			223.92
		Purchase Order #: 0 Voucher #: 176123 Invoice #: 449048311001			29.44
		Invoice Description: PENS			
		001-303-516 SUPPLIES/OPERATING			29.44
		Purchase Order #: 0 Voucher #: 176124 Invoice #: 449048312001			81.20
		Invoice Description: TONER			
		001-303-516 SUPPLIES/OPERATING			81.20
		Purchase Order #: 0 Voucher #: 176125 Invoice #: 449048314001			165.09
		Invoice Description: TONER			
		001-303-516 SUPPLIES/OPERATING			165.09
		Purchase Order #: 0 Voucher #: 176126 Invoice #: 449048315001			82.54
		Invoice Description: TONER			
		001-303-516 SUPPLIES/OPERATING			82.54
*****	12/17/2025	1520 ORANGE BEACH AUTO & MARINE	Check	No	22.47
		Purchase Order #: 0 Voucher #: 176127 Invoice #: 77403			6.69
		Invoice Description: CAP SCRWS			
		403-676-516 SUPPLIES/OPERATING			6.69
		Purchase Order #: 0 Voucher #: 176128 Invoice #: 77421			15.78
		Invoice Description: ANCHR SHKL/ SNAP			
		403-676-516 SUPPLIES/OPERATING			15.78
*****	12/17/2025	6752 ORANGE BEACH HARDWARE STORE	Check	No	48.95
		Purchase Order #: 0 Voucher #: 175779 Invoice #: 59208			4.97
		Invoice Description: KEYS/ ID TAG			
		001-410-616 RPR/MAINT PLANT/BLDGS			4.97
		Purchase Order #: 0 Voucher #: 176129 Invoice #: 59440			43.98
		Invoice Description: CHN SAW RPL PARTS			
		001-614-743 NRDA MARINE DEBRIS GRANT			43.98
*****	12/17/2025	6382 PARIS ACE HARDWARE	Check	No	2,794.82
		Purchase Order #: 0 Voucher #: 175624 Invoice #: 35585527			50.53
		Invoice Description: FLEX DUCT/ DCT CNNCTR			
		001-210-516 SUPPLIES/OPERATING			50.53
		Purchase Order #: 0 Voucher #: 175625 Invoice #: 35591471			84.30
		Invoice Description: TAPES/ WR STRPPR/ CLAM PLGS			
		001-200-516 SUPPLIES/OPERATING			84.30
		Purchase Order #: 0 Voucher #: 175626 Invoice #: 35591957			123.88
		Invoice Description: TAPE/ ADPTRS/ CBL TIES			
		001-200-516 SUPPLIES/OPERATING			123.88
		Purchase Order #: 0 Voucher #: 175627 Invoice #: 35592120			5.03
		Invoice Description: WIRE HOOK			

ACCOUNTS PAYABLE CHECK REGISTER

Check Register for 12/4/2025 to 12/17/2025 & Check Numbers 0 to 2147483647

Cash Account 001-000-011

Check Number	Check Date	Vendor Number / Name	Payment Type	EPay	Amount (\$)
		001-100-516 SUPPLIES/OPERATING		5.03	
		<i>Purchase Order #:</i> 0 <i>Voucher #:</i> 175628 <i>Invoice #:</i> 35592234			50.37
		<i>Invoice Description:</i> TAPE/ OUTDR CLNR			
		001-100-620 RPR/MAINT GROUNDS		50.37	
		<i>Purchase Order #:</i> 0 <i>Voucher #:</i> 175629 <i>Invoice #:</i> 35592531			16.52
		<i>Invoice Description:</i> CEILING HOOKS			
		001-200-516 SUPPLIES/OPERATING		16.52	
		<i>Purchase Order #:</i> 0 <i>Voucher #:</i> 175630 <i>Invoice #:</i> 35592553			23.26
		<i>Invoice Description:</i> EXCHG CLNG HKS/ STPLR/ STPLS			
		001-200-516 SUPPLIES/OPERATING		23.26	
		<i>Purchase Order #:</i> 0 <i>Voucher #:</i> 175631 <i>Invoice #:</i> 35592645			26.99
		<i>Invoice Description:</i> BOOTS			
		001-200-516 SUPPLIES/OPERATING		26.99	
		<i>Purchase Order #:</i> 0 <i>Voucher #:</i> 175632 <i>Invoice #:</i> 35592675			45.84
		<i>Invoice Description:</i> PVC CAPS/ PVC CMNT/ PRMR			
		001-100-620 RPR/MAINT GROUNDS		45.84	
		<i>Purchase Order #:</i> 0 <i>Voucher #:</i> 175633 <i>Invoice #:</i> 49547188			34.18
		<i>Invoice Description:</i> BAND SAW BLDS			
		001-200-516 SUPPLIES/OPERATING		34.18	
		<i>Purchase Order #:</i> 0 <i>Voucher #:</i> 175780 <i>Invoice #:</i> 35590143			103.15
		<i>Invoice Description:</i> SCRWS/ DRLL BITS			
		001-410-620 RPR/MAINT GROUNDS		103.15	
		<i>Purchase Order #:</i> 0 <i>Voucher #:</i> 175781 <i>Invoice #:</i> 35590212			15.29
		<i>Invoice Description:</i> LT CNTL SNSR			
		001-410-652 STATE PARK EXPENSES		15.29	
		<i>Purchase Order #:</i> 0 <i>Voucher #:</i> 175782 <i>Invoice #:</i> 35590259			52.74
		<i>Invoice Description:</i> SCREWS			
		001-410-620 RPR/MAINT GROUNDS		52.74	
		<i>Purchase Order #:</i> 0 <i>Voucher #:</i> 175783 <i>Invoice #:</i> 35591810			32.96
		<i>Invoice Description:</i> PIPES/ CPLNGS			
		001-303-620 RPR/MAINT GROUNDS		32.96	
		<i>Purchase Order #:</i> 0 <i>Voucher #:</i> 175784 <i>Invoice #:</i> 35592011			28.44
		<i>Invoice Description:</i> DOOR HLDRS/ SPRY PNT/ DOOR STOP			
		001-609-724 REC CTR COMPLEX/CONTORNO		28.44	
		<i>Purchase Order #:</i> 0 <i>Voucher #:</i> 175785 <i>Invoice #:</i> 35592092			26.28
		<i>Invoice Description:</i> SCSRS/ GLUE/ SPNG			
		001-410-513 SUPPLIES/JANITORIAL		26.28	
		<i>Purchase Order #:</i> 0 <i>Voucher #:</i> 175786 <i>Invoice #:</i> 35592104			49.99
		<i>Invoice Description:</i> #363 TOW KIT			
		001-410-622 RPR/MAINT VEHICLES		49.99	
		<i>Purchase Order #:</i> 0 <i>Voucher #:</i> 175787 <i>Invoice #:</i> 35592391			15.00
		<i>Invoice Description:</i> ELBOWS/ TEES			
		001-410-616 RPR/MAINT PLANT/BLDGS		15.00	
		<i>Purchase Order #:</i> 0 <i>Voucher #:</i> 175788 <i>Invoice #:</i> 35592559			30.79
		<i>Invoice Description:</i> KEYS/ STPLS			
		001-300-516 SUPPLIES/OPERATING		30.79	
		<i>Purchase Order #:</i> 0 <i>Voucher #:</i> 175789 <i>Invoice #:</i> 35593124			53.06
		<i>Invoice Description:</i> WSHRS/ SCRWS			

ACCOUNTS PAYABLE CHECK REGISTER

Check Register for 12/4/2025 to 12/17/2025 & Check Numbers 0 to 2147483647

Cash Account 001-000-011

Check Number	Check Date	Vendor Number / Name	Payment Type	EPay	Amount (\$)
		001-301-516 SUPPLIES/OPERATING		53.06	
		<i>Purchase Order #:</i> 0 <i>Voucher #:</i> 175790 <i>Invoice #:</i> 35593140			11.86
		<i>Invoice Description:</i> PNTBRUSH SET			
		001-100-620 RPR/MAINT GROUNDS		11.86	
		<i>Purchase Order #:</i> 0 <i>Voucher #:</i> 175791 <i>Invoice #:</i> 35594089			98.06
		<i>Invoice Description:</i> ELEC OUTLETS			
		001-301-516 SUPPLIES/OPERATING		98.06	
		<i>Purchase Order #:</i> 0 <i>Voucher #:</i> 175792 <i>Invoice #:</i> 35594378			27.89
		<i>Invoice Description:</i> WASHERS			
		001-301-516 SUPPLIES/OPERATING		27.89	
		<i>Purchase Order #:</i> 0 <i>Voucher #:</i> 175793 <i>Invoice #:</i> 35594689			96.00
		<i>Invoice Description:</i> PLSTC CHAIN			
		001-301-516 SUPPLIES/OPERATING		96.00	
		<i>Purchase Order #:</i> 0 <i>Voucher #:</i> 175794 <i>Invoice #:</i> 49547187			11.92
		<i>Invoice Description:</i> #234 NUTS/ BOLTS			
		001-100-622 RPR/MAINT VEHICLES		11.92	
		<i>Purchase Order #:</i> 0 <i>Voucher #:</i> 176130 <i>Invoice #:</i> 35588007			102.27
		<i>Invoice Description:</i> DOOR LVR/ DEADBLT LK			
		001-303-616 RPR/MAINT PLANT/BLDGS		102.27	
		<i>Purchase Order #:</i> 0 <i>Voucher #:</i> 176131 <i>Invoice #:</i> 35592632			288.00
		<i>Invoice Description:</i> POSTHL DGGR/ PSHBRM/ SPADE			
		403-676-516 SUPPLIES/OPERATING		288.00	
		<i>Purchase Order #:</i> 0 <i>Voucher #:</i> 176132 <i>Invoice #:</i> 35593087			23.05
		<i>Invoice Description:</i> INSC TICDS			
		001-302-616 RPR/MAINT PLANT/BLDGS		23.05	
		<i>Purchase Order #:</i> 0 <i>Voucher #:</i> 176133 <i>Invoice #:</i> 35593286			192.92
		<i>Invoice Description:</i> SRG PRTCTRS/ SMK DTCTR BTTRIES			
		001-175-507 EQUIPMENT/SMALL		192.92	
		<i>Purchase Order #:</i> 0 <i>Voucher #:</i> 176134 <i>Invoice #:</i> 35593944			52.88
		<i>Invoice Description:</i> AA/ AAA BATTERIES/ NUTS			
		403-676-516 SUPPLIES/OPERATING		52.88	
		<i>Purchase Order #:</i> 0 <i>Voucher #:</i> 176135 <i>Invoice #:</i> 35593998			15.02
		<i>Invoice Description:</i> PNTR TAPE/ MSKNG PPR			
		001-609-728 GOLF COURSE		15.02	
		<i>Purchase Order #:</i> 0 <i>Voucher #:</i> 176136 <i>Invoice #:</i> 35594065			329.99
		<i>Invoice Description:</i> NAILER			
		001-200-507 EQUIPMENT/SMALL		329.99	
		<i>Purchase Order #:</i> 0 <i>Voucher #:</i> 176137 <i>Invoice #:</i> 35594229			117.32
		<i>Invoice Description:</i> CUT WHLS/ SLDG HMMR/ ANCHR SHKLS			
		403-676-516 SUPPLIES/OPERATING		117.32	
		<i>Purchase Order #:</i> 0 <i>Voucher #:</i> 176138 <i>Invoice #:</i> 35594251			19.23
		<i>Invoice Description:</i> QK LNK/ CBL CLPS/ WIRE/ CBL			
		403-676-516 SUPPLIES/OPERATING		19.23	
		<i>Purchase Order #:</i> 0 <i>Voucher #:</i> 176139 <i>Invoice #:</i> 35594489			56.99
		<i>Invoice Description:</i> DRILL BIT			
		001-410-620 RPR/MAINT GROUNDS		56.99	
		<i>Purchase Order #:</i> 0 <i>Voucher #:</i> 176140 <i>Invoice #:</i> 35594972			35.07
		<i>Invoice Description:</i> CHAINS/ SPRNG SNAP			

ACCOUNTS PAYABLE CHECK REGISTER

Check Register for 12/4/2025 to 12/17/2025 & Check Numbers 0 to 2147483647

Cash Account 001-000-011

Check Number	Check Date	Vendor Number / Name	Payment Type	EPay	Amount (\$)
		001-100-516 SUPPLIES/OPERATING			35.07
		<i>Purchase Order #:</i> 0 <i>Voucher #:</i> 176141 <i>Invoice #:</i> 35596796			28.38
		<i>Invoice Description:</i> WASH BRSH/ 9V BTRY			
		001-100-622 RPR/MAINT VEHICLES			19.79
		001-100-516 SUPPLIES/OPERATING			8.59
		<i>Purchase Order #:</i> 0 <i>Voucher #:</i> 176142 <i>Invoice #:</i> 35597247			16.19
		<i>Invoice Description:</i> ICE MKR KIT			
		001-350-618 RPR/MAINT EQUIPMENT			16.19
		<i>Purchase Order #:</i> 0 <i>Voucher #:</i> 176143 <i>Invoice #:</i> 35597837			45.98
		<i>Invoice Description:</i> BIT SET/ PINE STRAW			
		001-301-516 SUPPLIES/OPERATING			45.98
		<i>Purchase Order #:</i> 0 <i>Voucher #:</i> 176144 <i>Invoice #:</i> 35597908			21.56
		<i>Invoice Description:</i> NUTS/ BOLTS/ GLOVES			
		001-100-516 SUPPLIES/OPERATING			21.56
		<i>Purchase Order #:</i> 0 <i>Voucher #:</i> 176145 <i>Invoice #:</i> 35597993			155.92
		<i>Invoice Description:</i> PINE STRAW/ 20LB LP TNK			
		001-301-516 SUPPLIES/OPERATING			155.92
		<i>Purchase Order #:</i> 0 <i>Voucher #:</i> 176146 <i>Invoice #:</i> 35598276			89.99
		<i>Invoice Description:</i> SPC HTR			
		001-301-516 SUPPLIES/OPERATING			89.99
		<i>Purchase Order #:</i> 0 <i>Voucher #:</i> 176147 <i>Invoice #:</i> 45590261			89.73
		<i>Invoice Description:</i> PAINT PENS/ DUCT TAPE			
		001-200-516 SUPPLIES/OPERATING			89.73
*****	12/17/2025	290 PARISH TRACTOR COMPANY, LLC	Check	No	260.53
		<i>Purchase Order #:</i> 0 <i>Voucher #:</i> 176148 <i>Invoice #:</i> P31536			156.85
		<i>Invoice Description:</i> #720 AUX WR			
		001-200-618 RPR/MAINT EQUIPMENT			156.85
		<i>Purchase Order #:</i> 0 <i>Voucher #:</i> 176149 <i>Invoice #:</i> P31607			103.68
		<i>Invoice Description:</i> STK WEEDETR MIX OIL			
		001-210-510 GAS/OIL			103.68
*****	12/17/2025	8883 PARKS MEDICAL ELECTRONICS, INC.	Check	No	943.34
		<i>Purchase Order #:</i> 0 <i>Voucher #:</i> 176150 <i>Invoice #:</i> 412500			943.34
		<i>Invoice Description:</i> LESS \$92.00 TAX DPPLR FLW DTCTR			
		001-614-743 NRDA MARINE DEBRIS GRANT			943.34
*****	12/17/2025	6907 PAT PAGE	Check	No	15.60
		<i>Purchase Order #:</i> 0 <i>Voucher #:</i> 175882 <i>Invoice #:</i> 251130			15.60
		<i>Invoice Description:</i> NOV 2025			
		430-682-660 RESALE INV/ARTISTS			15.60
*****	12/17/2025	6289 PATRICIA J. WATTAM	Check	No	25.03
		<i>Purchase Order #:</i> 0 <i>Voucher #:</i> 175883 <i>Invoice #:</i> 251130			25.03
		<i>Invoice Description:</i> NOV 2025			
		430-682-660 RESALE INV/ARTISTS			25.03
*****	12/17/2025	8455 PATTI K. WOMMER	Check	No	26.00
		<i>Purchase Order #:</i> 0 <i>Voucher #:</i> 175884 <i>Invoice #:</i> 251130			26.00
		<i>Invoice Description:</i> NOV 2025			
		430-682-660 RESALE INV/ARTISTS			26.00

ACCOUNTS PAYABLE CHECK REGISTER

Check Register for 12/4/2025 to 12/17/2025 & Check Numbers 0 to 2147483647

Cash Account 001-000-011

Check Number	Check Date	Vendor Number / Name	Payment Type	EPay	Amount (\$)
*****	12/17/2025	6934 PETER VON GLAHN	Check	No	388.05
		Purchase Order #: 0 Voucher #: 175885 Invoice #: 251130			388.05
		Invoice Description: NOV 2025			
		430-682-660 RESALE INVI/ARTISTS			388.05
*****	12/17/2025	7966 PETHEALTH SERVICES (USA) LLC	Check	No	635.00
		Purchase Order #: 0 Voucher #: 176254 Invoice #: SIUN15269526			635.00
		Invoice Description: MICROCHIPS			
		001-100-612 PROFESSIONAL FEES			635.00
*****	12/17/2025	5676 PHOENIX WEST OWNER'S ASSOC	Check	No	143.48
		Purchase Order #: 0 Voucher #: 176151 Invoice #: 2025-12			143.48
		Invoice Description: DEC 2025			
		001-175-605 COMMUNICATIONS			143.48
*****	12/17/2025	8715 PREMIERE STAFFING SERVICES, LLC	Check	No	140.00
		Purchase Order #: 0 Voucher #: 175795 Invoice #: 16678			140.00
		Invoice Description: B CREAGER 11.15.25			
		001-300-612 PROFESSIONAL FEES			140.00
*****	12/17/2025	6074 PRINTING PROS	Check	No	2,095.14
		Purchase Order #: 0 Voucher #: 175634 Invoice #: 25090413			210.00
		Invoice Description: GRADUATION PGMS			
		001-175-516 SUPPLIES/OPERATING			210.00
		Purchase Order #: 0 Voucher #: 175796 Invoice #: 25090543			750.00
		Invoice Description: 3" DECALS			
		001-410-650 AUDUBON			750.00
		Purchase Order #: 0 Voucher #: 175797 Invoice #: 25090570			80.00
		Invoice Description: RSTRM/ LCKR RM SIGNS			
		001-301-516 SUPPLIES/OPERATING			80.00
		Purchase Order #: 0 Voucher #: 175798 Invoice #: 25090652			848.00
		Invoice Description: ED POSTERS			
		001-410-612 PROFESSIONAL FEES			848.00
		Purchase Order #: 0 Voucher #: 175799 Invoice #: 25090655			140.40
		Invoice Description: BINGO SIGNS			
		001-300-516 SUPPLIES/OPERATING			140.40
		Purchase Order #: 0 Voucher #: 176152 Invoice #: 25090583			66.74
		Invoice Description: 'FRZN' POSTERS			
		001-375-636 PRODUCTION COST			66.74
*****	12/17/2025	5450 PRO CHEM INC.	Check	No	1,188.01
		Purchase Order #: 0 Voucher #: 175635 Invoice #: 204468			342.55
		Invoice Description: PENETRNT/ PNT			
		001-210-516 SUPPLIES/OPERATING			342.55
		Purchase Order #: 0 Voucher #: 175636 Invoice #: 204648			261.14
		Invoice Description: GLVS			
		001-210-516 SUPPLIES/OPERATING			261.14
		Purchase Order #: 0 Voucher #: 176153 Invoice #: 204937			325.26
		Invoice Description: GLOVES			
		001-210-516 SUPPLIES/OPERATING			325.26
		Purchase Order #: 0 Voucher #: 176154 Invoice #: 205187			259.06

ACCOUNTS PAYABLE CHECK REGISTER

Check Register for 12/4/2025 to 12/17/2025 & Check Numbers 0 to 2147483647

Cash Account 001-000-011

Check Number	Check Date	Vendor Number / Name	Payment Type	EPay	Amount (\$)
		<i>Invoice Description:</i> ULTRA WIPES			
		001-210-516 SUPPLIES/OPERATING			259.06
*****	12/17/2025	6008 PUBLIX SUPER MARKETS, INC	Check	No	378.10
	<i>Purchase Order #:</i> 0	<i>Voucher #:</i> 175800	<i>Invoice #:</i> 1270620134		25.94
		<i>Invoice Description:</i> INMATE RX			
		001-110-516 SUPPLIES/OPERATING			25.94
	<i>Purchase Order #:</i> 0	<i>Voucher #:</i> 175801	<i>Invoice #:</i> 1271047339		82.75
		<i>Invoice Description:</i> TRKY/ HAM/ RSTR PAN/ PLTS			
		001-304-516 SUPPLIES/OPERATING			82.75
	<i>Purchase Order #:</i> 0	<i>Voucher #:</i> 175802	<i>Invoice #:</i> 1274138398		36.04
		<i>Invoice Description:</i> LESS \$3.60 TAX PPR PLTS/ PLSTC CTRLRY			
		001-100-516 SUPPLIES/OPERATING			36.04
	<i>Purchase Order #:</i> 0	<i>Voucher #:</i> 176155	<i>Invoice #:</i> 000541776620		13.01
		<i>Invoice Description:</i> INMATE RX			
		001-110-516 SUPPLIES/OPERATING			13.01
	<i>Purchase Order #:</i> 0	<i>Voucher #:</i> 176156	<i>Invoice #:</i> 000575239121		188.40
		<i>Invoice Description:</i> CNCL RTR LNCH 12.02.25			
		001-001-516 SUPPLIES/OPERATING			188.40
	<i>Purchase Order #:</i> 0	<i>Voucher #:</i> 176157	<i>Invoice #:</i> 0998528252		69.38
		<i>Invoice Description:</i> PRY MIX/ PLTS/ CHPS/ COFFEE			
		001-001-516 SUPPLIES/OPERATING			69.38
	<i>Purchase Order #:</i> 0	<i>Voucher #:</i> 176158	<i>Invoice #:</i> DOC 2105706346		-37.42
		<i>Invoice Description:</i> CRT- PYMT APPLCTN			
		001-110-516 SUPPLIES/OPERATING			-37.42
*****	12/17/2025	8588 PUKKA LLC	Check	No	1,009.20
	<i>Purchase Order #:</i> 0	<i>Voucher #:</i> 175803	<i>Invoice #:</i> IH07076-IN		1,009.20
		<i>Invoice Description:</i> HATS			
		001-301-516 SUPPLIES/OPERATING			1,009.20
*****	12/17/2025	7936 QUALITY RESTORATIONS, INC.	Check	No	141,510.00
	<i>Purchase Order #:</i> 250492	<i>Voucher #:</i> 175637	<i>Invoice #:</i> 251117		54,764.00
		<i>Invoice Description:</i> RENO BTHRMS/ LCKR RM			
		001-609-721 SPORTSPLEX			54,764.00
	<i>Purchase Order #:</i> 0	<i>Voucher #:</i> 175804	<i>Invoice #:</i> 251124		2,493.00
		<i>Invoice Description:</i> LCKR RM/ RSTRM RPRS			
		001-301-616 RPR/MAINT PLANT/BLDGS			2,493.00
	<i>Purchase Order #:</i> 0	<i>Voucher #:</i> 175805	<i>Invoice #:</i> 251124A		2,485.00
		<i>Invoice Description:</i> TNNS CTR RENO			
		001-609-711 PICKLEBALL			2,485.00
	<i>Purchase Order #:</i> 250459	<i>Voucher #:</i> 176159	<i>Invoice #:</i> 251124B		81,768.00
		<i>Invoice Description:</i> REC CTR FLOOR RPL			
		001-350-616 RPR/MAINT PLANT/BLDGS			81,768.00
*****	12/17/2025	8000 RAYMOND L. ALEXANDER	Check	No	285.00
	<i>Purchase Order #:</i> 0	<i>Voucher #:</i> 175638	<i>Invoice #:</i> 250924		285.00
		<i>Invoice Description:</i> RMB EMT EXAM FEE			
		001-175-630 TRAINING/TRAVEL			285.00
*****	12/17/2025	7404 RESCUE SYSTEMS UNLIMITED	Check	No	1,735.00

ACCOUNTS PAYABLE CHECK REGISTER

Check Register for 12/4/2025 to 12/17/2025 & Check Numbers 0 to 2147483647

Cash Account 001-000-011

Check Number	Check Date	Vendor Number / Name	Payment Type	EPay	Amount (\$)
		Purchase Order #: 0 Voucher #: 176160 Invoice #: 13082			1,735.00
		Invoice Description: EXTRCTN TL SVC			
		001-175-630 TRAINING/TRAVEL		1,735.00	
****	12/17/2025	8318 RHONDA L. ROBINS	Check	No	181.37
		Purchase Order #: 0 Voucher #: 175886 Invoice #: 251130			181.37
		Invoice Description: NOV 2025			
		430-682-660 RESALE INVI/ARTISTS		181.37	
****	12/17/2025	3229 ROBERTSDALE FEED STORE	Check	No	178.49
		Purchase Order #: 0 Voucher #: 175806 Invoice #: 10031			22.52
		Invoice Description: WLDLF FOOD			
		001-410-516 SUPPLIES/OPERATING		22.52	
		Purchase Order #: 0 Voucher #: 175807 Invoice #: 10043			155.97
		Invoice Description: LESS \$14.04 TAX WLDLF FOOD			
		001-410-516 SUPPLIES/OPERATING		155.97	
****	12/17/2025	8683 ROBIN J.W. ANDERSON	Check	No	13.00
		Purchase Order #: 0 Voucher #: 175887 Invoice #: 251130			13.00
		Invoice Description: NOV 2025			
		430-682-660 RESALE INVI/ARTISTS		13.00	
****	12/17/2025	6778 RODNEY KERVIN	Check	No	56.55
		Purchase Order #: 0 Voucher #: 175888 Invoice #: 251130			56.55
		Invoice Description: NOV 2025			
		430-682-660 RESALE INVI/ARTISTS		56.55	
****	12/17/2025	8538 SALLY A. WYRICK	Check	No	60.00
		Purchase Order #: 0 Voucher #: 176161 Invoice #: 039			30.00
		Invoice Description: 11/17-11/21/25 WTR FTNSS			
		001-302-612 PROFESSIONAL FEES		30.00	
		Purchase Order #: 0 Voucher #: 176162 Invoice #: 040			30.00
		Invoice Description: 11/24-11/28/25 WTR FTNSS			
		001-302-612 PROFESSIONAL FEES		30.00	
****	12/17/2025	6880 SALLY T. MILLER	Check	No	146.27
		Purchase Order #: 0 Voucher #: 175889 Invoice #: 251130			146.27
		Invoice Description: NOV 2025			
		430-682-660 RESALE INVI/ARTISTS		146.27	
****	12/17/2025	1924 SAM'S CLUB DIRECT	Check	No	1,910.74
		Purchase Order #: 0 Voucher #: 176163 Invoice #: 10370137039			1,362.98
		Invoice Description: ADRNDK CHRS/ BSTRO TBLS			
		001-609-730 P & R CAPITAL EQUIPMENT		1,362.98	
		Purchase Order #: 0 Voucher #: 176164 Invoice #: 3813			547.76
		Invoice Description: SNCKS/ VNDNG/ CNCSSNS			
		001-303-660 COST OF GOODS SOLD RETAIL		107.58	
		001-001-641 EMPLOYEE ADVISORY COMM		41.96	
		001-301-516 SUPPLIES/OPERATING		398.22	
****	12/17/2025	1370 SANDY SANSING CHEVROLET OF FOLEY	Check	No	446.08
		Purchase Order #: 0 Voucher #: 175639 Invoice #: 740282			283.73

ACCOUNTS PAYABLE CHECK REGISTER

Check Register for 12/4/2025 to 12/17/2025 & Check Numbers 0 to 2147483647

Cash Account 001-000-011

Check Number	Check Date	Vendor Number / Name	Payment Type	EPay	Amount (\$)
<i>Invoice Description:</i> #462 MANIFLD/ GASKTS					
	001-175-622	RPR/MAINT VEHICLES			283.73
<i>Purchase Order #:</i>	0	<i>Voucher #:</i> 176165	<i>Invoice #:</i> 740305		113.12
<i>Invoice Description:</i> #462 INJCTR KIT					
	001-175-622	RPR/MAINT VEHICLES			113.12
<i>Purchase Order #:</i>	0	<i>Voucher #:</i> 176166	<i>Invoice #:</i> 740308		49.23
<i>Invoice Description:</i> #462 HARNESS					
	001-175-622	RPR/MAINT VEHICLES			49.23
*****	12/17/2025	8577 SASSY TOOLS, LLC	Check	No	179.99
<i>Purchase Order #:</i>	0	<i>Voucher #:</i> 176167	<i>Invoice #:</i> D14407		179.99
<i>Invoice Description:</i> RTCHTNG FLR NUT WRNCH SET					
	001-200-516	SUPPLIES/OPERATING			179.99
*****	12/17/2025	8725 SECUREVISION, LLC	Check	No	1,350.00
<i>Purchase Order #:</i>	0	<i>Voucher #:</i> 175808	<i>Invoice #:</i> 102024		1,350.00
<i>Invoice Description:</i> DEC 2025					
	001-325-612	PROFESSIONAL FEES			1,350.00
*****	12/17/2025	5904 SEW SWEET	Check	No	596.00
<i>Purchase Order #:</i>	0	<i>Voucher #:</i> 176168	<i>Invoice #:</i> 1686		596.00
<i>Invoice Description:</i> PTCH/ HSH MK SEWING					
	001-110-540	UNIFORMS			118.00
	001-100-540	UNIFORMS			478.00
*****	12/17/2025	8150 SHARON OWENS	Check	No	663.01
<i>Purchase Order #:</i>	0	<i>Voucher #:</i> 175890	<i>Invoice #:</i> 251130		663.01
<i>Invoice Description:</i> NOV 2025					
	430-682-660	RESALE INV/ARTISTS			663.01
*****	12/17/2025	1930 SHERWIN-WILLIAMS	Check	No	30,298.09
<i>Purchase Order #:</i>	0	<i>Voucher #:</i> 175640	<i>Invoice #:</i> 93525138851125		169.12
<i>Invoice Description:</i> TRFFC PNT/ RLLR KIT/ RLLRS					
	001-100-616	RPR/MAINT PLANT/BLDGS			169.12
<i>Purchase Order #:</i>	0	<i>Voucher #:</i> 176169	<i>Invoice #:</i> 06988115661125		-5,940.00
<i>Invoice Description:</i> CRDT- FLRNG MATLS					
	001-350-616	RPR/MAINT PLANT/BLDGS			-5,940.00
<i>Purchase Order #:</i>	0	<i>Voucher #:</i> 176170	<i>Invoice #:</i> 18070128791125		18,221.96
<i>Invoice Description:</i> FLRNG MATLS					
	001-350-616	RPR/MAINT PLANT/BLDGS			18,221.96
<i>Purchase Order #:</i>	0	<i>Voucher #:</i> 176171	<i>Invoice #:</i> 18088128791125		-18,150.00
<i>Invoice Description:</i> CRDT- FLRNG MATLS					
	001-350-616	RPR/MAINT PLANT/BLDGS			-18,150.00
<i>Purchase Order #:</i>	0	<i>Voucher #:</i> 176172	<i>Invoice #:</i> 18096128791125		14,850.00
<i>Invoice Description:</i> CRDT- FLRNG MATLS					
	001-350-616	RPR/MAINT PLANT/BLDGS			14,850.00
<i>Purchase Order #:</i>	0	<i>Voucher #:</i> 176173	<i>Invoice #:</i> 18628151881125		9,878.87
<i>Invoice Description:</i> FLRNG PNT					
	001-350-616	RPR/MAINT PLANT/BLDGS			9,878.87
<i>Purchase Order #:</i>	0	<i>Voucher #:</i> 176174	<i>Invoice #:</i> 19741151881125		33.14
<i>Invoice Description:</i> FLRNG MATLS					

ACCOUNTS PAYABLE CHECK REGISTER

Check Register for 12/4/2025 to 12/17/2025 & Check Numbers 0 to 2147483647

Cash Account 001-000-011

Check Number	Check Date	Vendor Number / Name	Payment Type	EPay	Amount (\$)
		001-350-616 RPR/MAINT PLANT/BLDGS		33.14	
		Purchase Order #: 0 Voucher #: 176175 Invoice #: 23206151881125			-1,095.00
		Invoice Description: CRDT- FLRNG MATLS			
		001-350-616 RPR/MAINT PLANT/BLDGS		-1,095.00	
		Purchase Order #: 0 Voucher #: 176176 Invoice #: 24363176521125			35.98
		Invoice Description: MRCL BOND			
		001-350-616 RPR/MAINT PLANT/BLDGS		35.98	
		Purchase Order #: 0 Voucher #: 176177 Invoice #: 29165141771125			-1,485.00
		Invoice Description: CRDT- FLRNG MATLS			
		001-350-616 RPR/MAINT PLANT/BLDGS		-1,485.00	
		Purchase Order #: 0 Voucher #: 176178 Invoice #: 29181141771125			-198.00
		Invoice Description: CRDT- FLRNG MATLS			
		001-350-616 RPR/MAINT PLANT/BLDGS		-198.00	
		Purchase Order #: 0 Voucher #: 176179 Invoice #: 34820141661125			2,008.00
		Invoice Description: FLRNG MATLS			
		001-350-616 RPR/MAINT PLANT/BLDGS		2,008.00	
		Purchase Order #: 0 Voucher #: 176180 Invoice #: 34895141661125			1,485.00
		Invoice Description: FLRNG MATLS			
		001-350-616 RPR/MAINT PLANT/BLDGS		1,485.00	
		Purchase Order #: 0 Voucher #: 176181 Invoice #: 45745132171125			71.96
		Invoice Description: MRCL BOND			
		001-350-616 RPR/MAINT PLANT/BLDGS		71.96	
		Purchase Order #: 0 Voucher #: 176182 Invoice #: 46453132171125			132.57
		Invoice Description: SLVNG AGNT			
		001-350-616 RPR/MAINT PLANT/BLDGS		132.57	
		Purchase Order #: 0 Voucher #: 176183 Invoice #: 72273213561125			71.96
		Invoice Description: MRCL BOND			
		001-350-616 RPR/MAINT PLANT/BLDGS		71.96	
		Purchase Order #: 0 Voucher #: 176184 Invoice #: 86057138851125			7,295.00
		Invoice Description: MRCL BOND			
		001-350-616 RPR/MAINT PLANT/BLDGS		7,295.00	
		Purchase Order #: 0 Voucher #: 176185 Invoice #: 87741138851125			8,147.28
		Invoice Description: MRCL BOND			
		001-350-616 RPR/MAINT PLANT/BLDGS		8,147.28	
		Purchase Order #: 0 Voucher #: 176186 Invoice #: 92196138851125			-1,035.84
		Invoice Description: CRDT- FLRNG MATLS			
		001-350-616 RPR/MAINT PLANT/BLDGS		-1,035.84	
		Purchase Order #: 0 Voucher #: 176187 Invoice #: 92204138851125			-1,965.88
		Invoice Description: CRDT- FLRNG MATLS			
		001-350-616 RPR/MAINT PLANT/BLDGS		-1,965.88	
		Purchase Order #: 0 Voucher #: 176188 Invoice #: 95157138851125			-2,535.00
		Invoice Description: CRDT- FLRNG MATLS			
		001-350-616 RPR/MAINT PLANT/BLDGS		-2,535.00	
		Purchase Order #: 0 Voucher #: 176189 Invoice #: 95389138851125			240.02
		Invoice Description: PRMR/ CAULK			
		001-614-742 ADEM 319 GRANT		240.02	
		Purchase Order #: 0 Voucher #: 176190 Invoice #: 9736-9			61.95
		Invoice Description: PAINT			

ACCOUNTS PAYABLE CHECK REGISTER

Check Register for 12/4/2025 to 12/17/2025 & Check Numbers 0 to 2147483647

Cash Account 001-000-011

Check Number	Check Date	Vendor Number / Name	Payment Type	EPay	Amount (\$)
		001-200-516 SUPPLIES/OPERATING			61.95
*****	12/17/2025	3723 SHORELINE ENVIRONMENTAL, INC.	Check	No	2,339.75
		Purchase Order #: 0 Voucher #: 175641 Invoice #: 75052			158.75
		Invoice Description: USD OIL/ ANTIFRZ/ FUEL PKUP			
		404-677-612 PROFESSIONAL FEES			158.75
		Purchase Order #: 0 Voucher #: 176191 Invoice #: 74099			206.00
		Invoice Description: USED TIRES PKUP			
		404-677-612 PROFESSIONAL FEES			206.00
		Purchase Order #: 0 Voucher #: 176192 Invoice #: 75053			1,975.00
		Invoice Description: SRPLS DIESEL PKUP			
		404-677-612 PROFESSIONAL FEES			1,975.00
*****	12/17/2025	8757 SILVER LINING STUDIO	Check	No	511.00
		Purchase Order #: 0 Voucher #: 175642 Invoice #: 5003			511.00
		Invoice Description: COASTAL TBL INSTRCTR			
		001-300-516 SUPPLIES/OPERATING			511.00
*****	12/17/2025	7668 SITEONE LANDSCAPE SUPPLY, LLC	Check	No	14,146.48
		Purchase Order #: 250370 Voucher #: 175809 Invoice #: 155893813-0012			4,405.10
		Invoice Description: PAVERS			
		001-614-742 ADEM 319 GRANT			4,405.10
		Purchase Order #: 250370 Voucher #: 175810 Invoice #: 155893813-0013			3,775.80
		Invoice Description: PAVERS			
		001-614-742 ADEM 319 GRANT			3,775.80
		Purchase Order #: 250370 Voucher #: 175811 Invoice #: 155893813-0014			4,405.10
		Invoice Description: PAVERS			
		001-614-742 ADEM 319 GRANT			4,405.10
		Purchase Order #: 0 Voucher #: 175812 Invoice #: 160785648-001			1,560.48
		Invoice Description: SPRNKLR RTRS/ VLV BX LIDS			
		001-301-620 RPR/MAINT GROUNDS			1,560.48
*****	12/17/2025	5966 SONIA A. SMITH	Check	No	35.76
		Purchase Order #: 0 Voucher #: 175891 Invoice #: 251130			35.76
		Invoice Description: NOV 2025			
		430-682-660 RESALE INV/ARTISTS			35.76
*****	12/17/2025	1964 SOUTH AL REGIONAL PLANNING COMMISSION	Check	No	1,192.00
		Purchase Order #: 0 Voucher #: 176193 Invoice #: 251118			1,192.00
		Invoice Description: 2025/26 1 OF 2			
		001-001-608 DUES/MEMBERSHIP/SUBSCRIPT			1,192.00
*****	12/17/2025	8885 SOUTHERN AG SERVICE, LLC	Check	No	1,088.00
		Purchase Order #: 0 Voucher #: 176194 Invoice #: 2025-922			1,088.00
		Invoice Description: 16 BAGS RYEGRASS SEED			
		001-303-620 RPR/MAINT GROUNDS			1,088.00
*****	12/17/2025	8855 SOUTHERN PUMP & CONTROL LLC	Check	No	20,433.00
		Purchase Order #: 250549 Voucher #: 175813 Invoice #: 02108274			20,433.00
		Invoice Description: WELL PMP/ MTR/ STK KIT/ INSTLL			
		001-303-620 RPR/MAINT GROUNDS			20,433.00

ACCOUNTS PAYABLE CHECK REGISTER

Check Register for 12/4/2025 to 12/17/2025 & Check Numbers 0 to 2147483647

Cash Account 001-000-011

Check Number	Check Date	Vendor Number / Name	Payment Type	EPay	Amount (\$)
*****	12/17/2025	6700 SOUTHERN RAPID HEALTHCARE INC	Check	No	600.00
		Purchase Order #: 0 Voucher #: 175814 Invoice #: 21058			600.00
		Invoice Description: RN JAIL VISITS			
		001-110-612 PROFESSIONAL FEES			600.00
*****	12/17/2025	7383 SOUTHERN TIRE MART, LLC	Check	No	1,903.32
		Purchase Order #: 0 Voucher #: 175643 Invoice #: 2030174258			595.20
		Invoice Description: #794 TIRES			
		001-200-622 RPR/MAINT VEHICLES			595.20
		Purchase Order #: 0 Voucher #: 175644 Invoice #: 2030174260			638.20
		Invoice Description: #23-204 TIRES			
		001-100-622 RPR/MAINT VEHICLES			638.20
		Purchase Order #: 0 Voucher #: 175645 Invoice #: 2030174261			669.92
		Invoice Description: #886 TIRES			
		001-210-622 RPR/MAINT VEHICLES			669.92
*****	12/17/2025	6756 STAPLES ADVANTAGE DEPT. ATL	Check	No	45,098.28
		Purchase Order #: 0 Voucher #: 175646 Invoice #: 6048576402			221.95
		Invoice Description: STG CBNT			
		001-020-516 SUPPLIES/OPERATING			221.95
		Purchase Order #: 0 Voucher #: 175647 Invoice #: 6048576404			-159.95
		Invoice Description: CRDT- OFC CHR			
		001-020-516 SUPPLIES/OPERATING			-159.95
		Purchase Order #: 0 Voucher #: 175648 Invoice #: 6048576407			179.99
		Invoice Description: PRINTER			
		001-010-507 EQUIPMENT/SMALL			179.99
		Purchase Order #: 250483 Voucher #: 176195 Invoice #: 6048576403			44,377.78
		Invoice Description: OFC/ BRK RM FRNTR			
		001-300-507 EQUIPMENT/SMALL			44,377.78
		Purchase Order #: 0 Voucher #: 176196 Invoice #: 6048576406			27.40
		Invoice Description: PST-IT NTS/ CLR PPR RM			
		001-001-516 SUPPLIES/OPERATING			27.40
		Purchase Order #: 0 Voucher #: 176197 Invoice #: 6048576409			399.04
		Invoice Description: P-TWLS/ T-TISS			
		001-001-513 SUPPLIES/JANITORIAL			399.04
		Purchase Order #: 0 Voucher #: 176198 Invoice #: 6049128123			52.07
		Invoice Description: COPY PPR/ PLNNR RFL			
		001-110-516 SUPPLIES/OPERATING			52.07
*****	12/17/2025	5955 STATE JUDICIAL ADMINISTRATION FUND	Check	No	742.62
		Purchase Order #: 0 Voucher #: 175854 Invoice #: 251201			742.62
		Invoice Description: NOV 2025			
		001-000-128 DUE COST FOR OTH AGENCIES			742.62
*****	12/17/2025	8146 STEARLYSLENS, LLC	Check	No	811.85
		Purchase Order #: 0 Voucher #: 175892 Invoice #: 251130			811.85
		Invoice Description: NOV 2025			
		430-682-660 RESALE INV/ARTISTS			811.85
*****	12/17/2025	4067 STEVE BURROW	Check	No	81.25
		Purchase Order #: 0 Voucher #: 175893 Invoice #: 251130			81.25

ACCOUNTS PAYABLE CHECK REGISTER

Check Register for 12/4/2025 to 12/17/2025 & Check Numbers 0 to 2147483647

Cash Account 001-000-011

Check Number	Check Date	Vendor Number / Name	Payment Type	EPay	Amount (\$)
		Invoice Description: NOV 2025 430-682-660 RESALE INV/ARTISTS			81.25
*****	12/17/2025	4066 STEVEN DARK	Check	No	104.00
		Purchase Order #: 0 Voucher #: 175894 Invoice #: 251130			104.00
		Invoice Description: NOV 2025 430-682-660 RESALE INV/ARTISTS			104.00
*****	12/17/2025	6171 STIVERS FORD LINCOLN	Check	No	49,116.00
		Purchase Order #: 250565 Voucher #: 176199 Invoice #: TED65229			49,116.00
		Invoice Description: '26 F350 XL 'D65229 001-609-721 SPORTSPLEX			49,116.00
*****	12/17/2025	2008 SUNBELT FIRE, INC.	Check	No	1,561.14
		Purchase Order #: 0 Voucher #: 175649 Invoice #: 00033262			954.14
		Invoice Description: #411,457 AKR RPR KITS 001-175-622 RPR/MAINT VEHICLES			954.14
		Purchase Order #: 0 Voucher #: 176200 Invoice #: 00033472			607.00
		Invoice Description: CALIBRTN CYLNDR 001-175-516 SUPPLIES/OPERATING			607.00
*****	12/17/2025	8024 SUNSHINE ARTIST	Check	No	350.00
		Purchase Order #: 0 Voucher #: 175815 Invoice #: 02108274			350.00
		Invoice Description: NEWSLETTER AD 430-682-650 EXHIBITIONS & PROMOTIONS			350.00
*****	12/17/2025	6107 SUNSOUTH, LLC	Check	No	3,236.17
		Purchase Order #: 0 Voucher #: 175816 Invoice #: 5363423			201.39
		Invoice Description: #762 STEPS/ NUTS/ BOLTS 001-410-618 RPR/MAINT EQUIPMENT			201.39
		Purchase Order #: 0 Voucher #: 176201 Invoice #: 5368065			620.86
		Invoice Description: #792 DRV SHFT 404-677-618 RPR/MAINT EQUIPMENT			620.86
		Purchase Order #: 0 Voucher #: 176202 Invoice #: 5369124			2,413.92
		Invoice Description: #761 DOOR/ TRIM 001-200-618 RPR/MAINT EQUIPMENT			2,413.92
*****	12/17/2025	8813 SUSAN W. KNOWLTON ARTIST LLC	Check	No	57.20
		Purchase Order #: 0 Voucher #: 175895 Invoice #: 251130			57.20
		Invoice Description: NOV 2025 430-682-660 RESALE INV/ARTISTS			57.20
*****	12/17/2025	205 SWDA BALDWIN COUNTY	Check	No	850.20
		Purchase Order #: 0 Voucher #: 176203 Invoice #: 17873			850.20
		Invoice Description: 28.34 TON RECYCL 404-677-612 PROFESSIONAL FEES			850.20
*****	12/17/2025	7962 SWEAT TIRE OF FOLEY	Check	No	644.03
		Purchase Order #: 0 Voucher #: 176204 Invoice #: 125137C			-0.52
		Invoice Description: TAX OVRPMNT CH174470 001-100-622 RPR/MAINT VEHICLES			-0.52
		Purchase Order #: 0 Voucher #: 176205 Invoice #: 127415			121.40

ACCOUNTS PAYABLE CHECK REGISTER

Check Register for 12/4/2025 to 12/17/2025 & Check Numbers 0 to 2147483647

Cash Account 001-000-011

Check Number	Check Date	Vendor Number / Name	Payment Type	EPay	Amount (\$)
		<i>Invoice Description:</i> #610 FLAT RPR			
		403-676-622 RPR/MAINT VEHICLES			121.40
		<i>Purchase Order #:</i> 0 <i>Voucher #:</i> 176206 <i>Invoice #:</i> 127827			523.15
		<i>Invoice Description:</i> STK TRLR TIRES			
		001-200-618 RPR/MAINT EQUIPMENT			523.15
*****	12/17/2025	2016 SWIFT SUPPLY, INC.	Check	No	2,086.07
		<i>Purchase Order #:</i> 0 <i>Voucher #:</i> 175817 <i>Invoice #:</i> 1027112			13.99
		<i>Invoice Description:</i> CAUTION TAPE			
		001-609-728 GOLF COURSE			13.99
		<i>Purchase Order #:</i> 0 <i>Voucher #:</i> 175818 <i>Invoice #:</i> 1028246			481.44
		<i>Invoice Description:</i> LMBR/ SCRWS/ CNCRT MIX			
		001-100-620 RPR/MAINT GROUNDS			481.44
		<i>Purchase Order #:</i> 0 <i>Voucher #:</i> 175819 <i>Invoice #:</i> 1028543			65.34
		<i>Invoice Description:</i> WASHERS/ SCREWS			
		001-301-516 SUPPLIES/OPERATING			65.34
		<i>Purchase Order #:</i> 0 <i>Voucher #:</i> 176207 <i>Invoice #:</i> 1026804			26.98
		<i>Invoice Description:</i> LMBR/ CNCRT MIX			
		001-609-724 REC CTR COMPLEX/CONTORNO			26.98
		<i>Purchase Order #:</i> 0 <i>Voucher #:</i> 176208 <i>Invoice #:</i> 1027582			1,483.38
		<i>Invoice Description:</i> LMBR			
		001-350-616 RPR/MAINT PLANT/BLDGS			1,483.38
		<i>Purchase Order #:</i> 0 <i>Voucher #:</i> 176209 <i>Invoice #:</i> 1027861			5.36
		<i>Invoice Description:</i> LMBR			
		001-614-742 ADEM 319 GRANT			5.36
		<i>Purchase Order #:</i> 0 <i>Voucher #:</i> 176210 <i>Invoice #:</i> 1028030			9.58
		<i>Invoice Description:</i> LTX SLNT/ MRKR			
		001-609-724 REC CTR COMPLEX/CONTORNO			9.58
*****	12/17/2025	3492 SYSCO GULF COAST INC	Check	No	1,266.60
		<i>Purchase Order #:</i> 0 <i>Voucher #:</i> 175820 <i>Invoice #:</i> 474296352 5			1,266.60
		<i>Invoice Description:</i> BF PTTIES/ FRNKS/ BBQ PRK/ BUNS			
		001-301-516 SUPPLIES/OPERATING			1,266.60
*****	12/17/2025	5662 THE CITIZENSHIP TRUST	Check	No	70.90
		<i>Purchase Order #:</i> 0 <i>Voucher #:</i> 175850 <i>Invoice #:</i> 251201			70.90
		<i>Invoice Description:</i> NOV 2025			
		001-000-128 DUE COST FOR OTH AGENCIES			70.90
*****	12/17/2025	6077 THE LAKE DOCTORS, INC	Check	No	900.00
		<i>Purchase Order #:</i> 0 <i>Voucher #:</i> 175650 <i>Invoice #:</i> 2082103			181.00
		<i>Invoice Description:</i> POND WTR MGMT			
		001-608-720 ROADWAYS/PAVING/RESURFACE			181.00
		<i>Purchase Order #:</i> 0 <i>Voucher #:</i> 176211 <i>Invoice #:</i> 2082064			510.00
		<i>Invoice Description:</i> POND WTR MGMT			
		001-303-620 RPR/MAINT GROUNDS			510.00
		<i>Purchase Order #:</i> 0 <i>Voucher #:</i> 176212 <i>Invoice #:</i> 2082358			209.00
		<i>Invoice Description:</i> POND WTR MGMT			
		001-303-620 RPR/MAINT GROUNDS			209.00
*****	12/17/2025	2035 THOMPSON TRACTOR CO, INC.	Check	No	1,776.96

ACCOUNTS PAYABLE CHECK REGISTER

Check Register for 12/4/2025 to 12/17/2025 & Check Numbers 0 to 2147483647

Cash Account 001-000-011

Check Number	Check Date	Vendor Number / Name	Payment Type	EPay	Amount (\$)
		Purchase Order #: 0 Invoice Description: STK HYDRCL OIL 001-200-510 GAS/OIL	Voucher #: 176213 Invoice #: SPI01756242		1,776.96
				1,776.96	
****	12/17/2025	451 TMOBILE USA, INC.	Check	No	117.72
		Purchase Order #: 0 Invoice Description: NOV 2025	Voucher #: 176214 Invoice #: 251121		117.72
		001-001-605 COMMUNICATIONS		38.25	
		001-030-605 COMMUNICATIONS		19.97	
		001-100-605 COMMUNICATIONS		59.50	
****	12/17/2025	5986 TRACTOR SUPPLY CO. CREDIT PLAN	Check	No	53.95
		Purchase Order #: 0 Invoice Description: SCREWS	Voucher #: 176215 Invoice #: 815919		53.95
		001-200-516 SUPPLIES/OPERATING		53.95	
****	12/17/2025	8859 TREVIPAY- WALMART	Check	No	693.84
		Purchase Order #: 0 Invoice Description: STPLR/ PLTS/ EXTN CRD/ BWLS	Voucher #: 175821 Invoice #: 91F80C78		73.14
		001-300-516 SUPPLIES/OPERATING		73.14	
		Purchase Order #: 0 Invoice Description: WHPD CRM/ SCE/ CTRLRY	Voucher #: 175822 Invoice #: C7CABB75		40.58
		001-300-516 SUPPLIES/OPERATING		40.58	
		Purchase Order #: 0 Invoice Description: AA/ AAA BTTRIES	Voucher #: 175823 Invoice #: F0E26507		37.34
		001-300-516 SUPPLIES/OPERATING		37.34	
		Purchase Order #: 0 Invoice Description: APPL CDR/ APPLS/ FRT	Voucher #: 175824 Invoice #: FCCBCD4		49.66
		001-300-516 SUPPLIES/OPERATING		49.66	
		Purchase Order #: 0 Invoice Description: WLDLF FOOD/ HAND SOAP	Voucher #: 175825 Invoice #: FEBA94A3		38.33
		001-410-516 SUPPLIES/OPERATING		38.33	
		Purchase Order #: 0 Invoice Description: WLDLF FOOD/ PREP H	Voucher #: 176216 Invoice #: A4378524		73.83
		001-410-516 SUPPLIES/OPERATING		73.83	
		Purchase Order #: 0 Invoice Description: EE CULINARY SPPLS	Voucher #: 176217 Invoice #: E5EE842F		38.05
		001-350-516 SUPPLIES/OPERATING		38.05	
		Purchase Order #: 0 Invoice Description: STPR/ GELT/ PENS/ SCSSRS	Voucher #: 176218 Invoice #: FCB7C82A		20.29
		001-350-516 SUPPLIES/OPERATING		20.29	
		Purchase Order #: 0 Invoice Description: EE CULINARY SPPLS	Voucher #: 176219 Invoice #: 15C9D874		17.94
		001-350-516 SUPPLIES/OPERATING		17.94	
		Purchase Order #: 0 Invoice Description: MRSHMLLWS	Voucher #: 176220 Invoice #: 18B1A3CD		2.65
		001-350-516 SUPPLIES/OPERATING		2.65	
		Purchase Order #: 0 Invoice Description: BTTLD WTR/ COOKIES	Voucher #: 176221 Invoice #: 357653D5		12.55
		001-030-516 SUPPLIES/OPERATING		12.55	

ACCOUNTS PAYABLE CHECK REGISTER

Check Register for 12/4/2025 to 12/17/2025 & Check Numbers 0 to 2147483647

Cash Account 001-000-011

Check Number	Check Date	Vendor Number / Name	Payment Type	EPay	Amount (\$)
<i>Purchase Order #:</i> 0		<i>Voucher #:</i> 176223	<i>Invoice #:</i> 4E0AAB65		-74.98
<i>Invoice Description:</i>		CRDT- CRM/ CFFEE/ SUGAR			
001-300-516		SUPPLIES/OPERATING		-74.98	
<i>Purchase Order #:</i> 0		<i>Voucher #:</i> 176224	<i>Invoice #:</i> 5BE7E187		69.22
<i>Invoice Description:</i>		CRM/ COFFEE/ HOT COCO			
001-300-513		SUPPLIES/JANITORIAL		6.16	
001-300-516		SUPPLIES/OPERATING		63.06	
<i>Purchase Order #:</i> 0		<i>Voucher #:</i> 176225	<i>Invoice #:</i> 7F33A665		74.98
<i>Invoice Description:</i>		CRM/ COFFEE/ HOT COCO			
001-300-516		SUPPLIES/OPERATING		74.98	
<i>Purchase Order #:</i> 0		<i>Voucher #:</i> 176226	<i>Invoice #:</i> 730C5BB3		116.08
<i>Invoice Description:</i>		SNCKS/ FRUIT/ CNDY/ LNCHBAGS			
430-682-516		SUPPLIES/OPERATING		116.08	
<i>Purchase Order #:</i> 0		<i>Voucher #:</i> 176227	<i>Invoice #:</i> 76D71B94		16.02
<i>Invoice Description:</i>		DSH SCRBBRS			
001-350-516		SUPPLIES/OPERATING		16.02	
<i>Purchase Order #:</i> 0		<i>Voucher #:</i> 176228	<i>Invoice #:</i> 9331CF04		-10.01
<i>Invoice Description:</i>		CRDT- EE CLNRY SPPLS			
001-350-516		SUPPLIES/OPERATING		-10.01	
<i>Purchase Order #:</i> 0		<i>Voucher #:</i> 176229	<i>Invoice #:</i> 99CC9801		98.17
<i>Invoice Description:</i>		EE BAKING SPPLS			
001-350-516		SUPPLIES/OPERATING		98.17	
*****	12/17/2025	8520 T&T UNIFORMS, INC	Check	No	3,005.00
<i>Purchase Order #:</i> 0		<i>Voucher #:</i> 175651	<i>Invoice #:</i> 225319		1,920.00
<i>Invoice Description:</i>		STNGRS/ BELTS/ PNTS/ SHRTS			
001-100-540		UNIFORMS		1,920.00	
<i>Purchase Order #:</i> 0		<i>Voucher #:</i> 175652	<i>Invoice #:</i> 225320		924.00
<i>Invoice Description:</i>		TACVSTS/ SHIRTS			
001-100-540		UNIFORMS		924.00	
<i>Purchase Order #:</i> 0		<i>Voucher #:</i> 176230	<i>Invoice #:</i> 226334		161.00
<i>Invoice Description:</i>		SHIRTS			
001-175-540		UNIFORMS		161.00	
*****	12/17/2025	8465 TURFPLUS ALABAMA, LLC	Check	No	7,475.00
<i>Purchase Order #:</i> 0		<i>Voucher #:</i> 175826	<i>Invoice #:</i> 2025112201		2,450.00
<i>Invoice Description:</i>		FIELD LN RMVL			
001-301-620		RPR/MAINT GROUNDS		2,450.00	
<i>Purchase Order #:</i> 0		<i>Voucher #:</i> 175827	<i>Invoice #:</i> 25112301		2,425.00
<i>Invoice Description:</i>		FIELD LN RMVL			
001-301-620		RPR/MAINT GROUNDS		2,425.00	
<i>Purchase Order #:</i> 0		<i>Voucher #:</i> 176231	<i>Invoice #:</i> 2025112601		850.00
<i>Invoice Description:</i>		PNT SCCR LNS			
001-301-620		RPR/MAINT GROUNDS		850.00	
<i>Purchase Order #:</i> 0		<i>Voucher #:</i> 176232	<i>Invoice #:</i> 2025112701		1,750.00
<i>Invoice Description:</i>		NAIA LOGO PNT			
001-301-620		RPR/MAINT GROUNDS		1,750.00	
*****	12/17/2025	5068 ULINE SHIPPING SUPPLY	Check	No	4,125.22
<i>Purchase Order #:</i> 0		<i>Voucher #:</i> 175828	<i>Invoice #:</i> 200913052		530.25

ACCOUNTS PAYABLE CHECK REGISTER

Check Register for 12/4/2025 to 12/17/2025 & Check Numbers 0 to 2147483647

Cash Account 001-000-011

Check Number	Check Date	Vendor Number / Name	Payment Type	EPay	Amount (\$)
<i>Invoice Description:</i>		BBL BAGS/ TSSU/ HTR			
	430-682-507	EQUIPMENT/SMALL			530.25
<i>Purchase Order #:</i>	0	<i>Voucher #:</i> 176233	<i>Invoice #:</i> 200512481		277.84
<i>Invoice Description:</i>		WLL MT DSPLY/ RPL PCKTS			
	001-410-616	RPR/MAINT PLANT/BLDGS			277.84
<i>Purchase Order #:</i>	0	<i>Voucher #:</i> 176234	<i>Invoice #:</i> 200535611		427.17
<i>Invoice Description:</i>		PRTBL PWR STN			
	411-681-507	EQUIPMENT/SMALL			427.17
<i>Purchase Order #:</i>	0	<i>Voucher #:</i> 176235	<i>Invoice #:</i> 200702302		760.06
<i>Invoice Description:</i>		MTL SMKR RCPTCL/ MOP HNDL			
	411-681-516	SUPPLIES/OPERATING			760.06
<i>Purchase Order #:</i>	0	<i>Voucher #:</i> 176236	<i>Invoice #:</i> 200809663		2,129.90
<i>Invoice Description:</i>		STL SHLVNG			
	001-210-516	SUPPLIES/OPERATING			2,129.90
*****	12/17/2025	6250 US FOODS INC	Check	No	1,015.20
<i>Purchase Order #:</i>	0	<i>Voucher #:</i> 175829	<i>Invoice #:</i> 2296197		588.18
<i>Invoice Description:</i>		INMATE CONCESSIONS			
	001-110-516	SUPPLIES/OPERATING			588.18
<i>Purchase Order #:</i>	0	<i>Voucher #:</i> 176237	<i>Invoice #:</i> 2497917		34.94
<i>Invoice Description:</i>		INMATE CONCESSIONS			
	001-110-516	SUPPLIES/OPERATING			34.94
<i>Purchase Order #:</i>	0	<i>Voucher #:</i> 176238	<i>Invoice #:</i> 2512465		392.08
<i>Invoice Description:</i>		INMATE CONCESSIONS			
	001-110-516	SUPPLIES/OPERATING			392.08
*****	12/17/2025	4004 VAN SCOYOC ASSOCIATES	Check	No	12,007.17
<i>Purchase Order #:</i>	0	<i>Voucher #:</i> 176239	<i>Invoice #:</i> 83441		6,007.17
<i>Invoice Description:</i>		LOBBYIST			
	001-001-612	PROFESSIONAL FEES			6,007.17
<i>Purchase Order #:</i>	0	<i>Voucher #:</i> 176240	<i>Invoice #:</i> 83727		6,000.00
<i>Invoice Description:</i>		LOBBYIST			
	001-001-612	PROFESSIONAL FEES			6,000.00
*****	12/17/2025	1299 VCA ANIMAL HOSPITALS, INC	Check	No	1,219.80
<i>Purchase Order #:</i>	0	<i>Voucher #:</i> 175830	<i>Invoice #:</i> 940623480		1,219.80
<i>Invoice Description:</i>		HUGO SHOTS/ MEDS/ BRD			
	001-100-612	PROFESSIONAL FEES			1,219.80
*****	12/17/2025	8805 VERIFIED FIRST LLC	Check	No	204.00
<i>Purchase Order #:</i>	0	<i>Voucher #:</i> 176241	<i>Invoice #:</i> INV-000580999		204.00
<i>Invoice Description:</i>		HR BCKGRND CHKS			
	001-001-612	PROFESSIONAL FEES			204.00
*****	12/17/2025	6602 VERIZON CONNECT FLEET USA, LLC	Check	No	177.50
<i>Purchase Order #:</i>	0	<i>Voucher #:</i> 176242	<i>Invoice #:</i> 633000085607		177.50
<i>Invoice Description:</i>		NOV 2025			
	404-677-612	PROFESSIONAL FEES			177.50
*****	12/17/2025	2156 VERMEER SOUTHEAST	Check	No	374.94
<i>Purchase Order #:</i>	0	<i>Voucher #:</i> 176243	<i>Invoice #:</i> P1968842		374.94

ACCOUNTS PAYABLE CHECK REGISTER

Check Register for 12/4/2025 to 12/17/2025 & Check Numbers 0 to 2147483647

Cash Account 001-000-011

Check Number	Check Date	Vendor Number / Name	Payment Type	EPay	Amount (\$)
		<i>Invoice Description:</i> #611 SLEEVES 403-676-618 RPR/MAINT SMALL EQUIP			374.94
*****	12/17/2025	2245 VINYL SOLUTIONS	Check	No	2,400.00
		<i>Purchase Order #:</i> 0 <i>Voucher #:</i> 175831 <i>Invoice #:</i> EMT-131502			600.00
		<i>Invoice Description:</i> #223,283,290 DTL 001-100-622 RPR/MAINT VEHICLES			600.00
		<i>Purchase Order #:</i> 0 <i>Voucher #:</i> 175832 <i>Invoice #:</i> EMT-131503			1,800.00
		<i>Invoice Description:</i> #223,283,290 RMV GRPHCS 001-100-622 RPR/MAINT VEHICLES			1,800.00
*****	12/17/2025	8326 VISION SECURITY TECHNOLOGIES	Check	No	10,010.65
		<i>Purchase Order #:</i> 250070 <i>Voucher #:</i> 176244 <i>Invoice #:</i> 30504			10,010.65
		<i>Invoice Description:</i> PD SCR TY STM 001-614-734 SHOOTING RANGE			10,010.65
*****	12/17/2025	2250 VISUAL EFFECTS	Check	No	973.00
		<i>Purchase Order #:</i> 0 <i>Voucher #:</i> 175653 <i>Invoice #:</i> 9996			328.00
		<i>Invoice Description:</i> EMBROIDERY 001-100-540 UNIFORMS			328.00
		<i>Purchase Order #:</i> 0 <i>Voucher #:</i> 176245 <i>Invoice #:</i> 10002			645.00
		<i>Invoice Description:</i> EMBROIDERY 001-100-540 UNIFORMS			645.00
*****	12/17/2025	2335 WALMART COMMUNITY	Check	No	176.92
		<i>Purchase Order #:</i> 0 <i>Voucher #:</i> 175833 <i>Invoice #:</i> 03457A			176.92
		<i>Invoice Description:</i> INK CRTRDG/ CFFEE CUPS 001-301-516 SUPPLIES/OPERATING			176.92
*****	12/17/2025	6004 WAREHOUSE PATIO, LLC	Check	No	1,203.00
		<i>Purchase Order #:</i> 0 <i>Voucher #:</i> 175834 <i>Invoice #:</i> 3770			1,203.00
		<i>Invoice Description:</i> LESS \$112.80 TAX LNGR/ CHR RESTRAP 001-302-618 RPR/MAINT EQUIPMENT			1,203.00
*****	12/17/2025	3104 WATERS NURSERY	Check	No	1,462.50
		<i>Purchase Order #:</i> 0 <i>Voucher #:</i> 175835 <i>Invoice #:</i> 35145			1,462.50
		<i>Invoice Description:</i> PLANTS/ FLWRS 001-304-620 RPR/MAINT GROUNDS			1,462.50
*****	12/17/2025	7345 WESCO GAS & WELDING SUPPLY INC	Check	No	349.91
		<i>Purchase Order #:</i> 0 <i>Voucher #:</i> 175654 <i>Invoice #:</i> 2001684176			259.08
		<i>Invoice Description:</i> CYLNDR RENT 001-200-516 SUPPLIES/OPERATING			259.08
		<i>Purchase Order #:</i> 0 <i>Voucher #:</i> 175836 <i>Invoice #:</i> 2001678764			90.83
		<i>Invoice Description:</i> CYNLDR RENT 430-682-516 SUPPLIES/OPERATING			90.83
*****	12/17/2025	8388 WILLIAM E. JOHNSTON	Check	No	110.51
		<i>Purchase Order #:</i> 0 <i>Voucher #:</i> 175896 <i>Invoice #:</i> 251130			110.51
		<i>Invoice Description:</i> NOV 2025 430-682-660 RESALE INV/ARTISTS			110.51
*****	12/17/2025	5950 WILLIAMS SCOTSMAN, INC	Check	No	70.30

ACCOUNTS PAYABLE CHECK REGISTER

Check Register for 12/4/2025 to 12/17/2025 & Check Numbers 0 to 2147483647

Cash Account 001-000-011

Check Number	Check Date	Vendor Number / Name	Payment Type	EPay	Amount (\$)
<i>Purchase Order #:</i> 0		<i>Voucher #:</i> 176247	<i>Invoice #:</i> 9025042137		70.30
<i>Invoice Description:</i> STG RNTL CLN 001-350-614 RENTALS				70.30	
**** 12/17/2025		7687 WILLIAM W. BEAZLEY	Check	No	1,800.00
<i>Purchase Order #:</i> 0		<i>Voucher #:</i> 176246	<i>Invoice #:</i> 251118		1,800.00
<i>Invoice Description:</i> NOV 2025 001-175-612 PROFESSIONAL FEES				1,800.00	
**** 12/17/2025		3955 WITTICHEN SUPPLY COMPANY	Check	No	3,657.85
<i>Purchase Order #:</i> 0		<i>Voucher #:</i> 175655	<i>Invoice #:</i> S108194858.001		199.63
<i>Invoice Description:</i> DGTL TRQ WRNCH 001-200-516 SUPPLIES/OPERATING				199.63	
<i>Purchase Order #:</i> 0		<i>Voucher #:</i> 175656	<i>Invoice #:</i> S108195082.001		2.90
<i>Invoice Description:</i> BATTERIES 001-200-516 SUPPLIES/OPERATING				2.90	
<i>Purchase Order #:</i> 0		<i>Voucher #:</i> 175837	<i>Invoice #:</i> S108222003.001		230.00
<i>Invoice Description:</i> HVAC RFRGRNT 001-301-618 RPR/MAINT EQUIPMENT				230.00	
<i>Purchase Order #:</i> 0		<i>Voucher #:</i> 176248	<i>Invoice #:</i> S108078581.001		1,851.00
<i>Invoice Description:</i> GAS FRNC/ MTR/ LP KIT 001-210-616 RPR/MAINT PLANT/BLDG				1,851.00	
<i>Purchase Order #:</i> 0		<i>Voucher #:</i> 176249	<i>Invoice #:</i> S108119205.001		51.51
<i>Invoice Description:</i> THRMOSTAT 001-210-616 RPR/MAINT PLANT/BLDG				51.51	
<i>Purchase Order #:</i> 0		<i>Voucher #:</i> 176250	<i>Invoice #:</i> S108210780.001		44.39
<i>Invoice Description:</i> COIL CLNR/ WR NUTS 001-200-516 SUPPLIES/OPERATING				44.39	
<i>Purchase Order #:</i> 0		<i>Voucher #:</i> 176251	<i>Invoice #:</i> S108246341.001		1,278.42
<i>Invoice Description:</i> HVAC UNIT 001-301-618 RPR/MAINT EQUIPMENT				1,278.42	
**** 12/17/2025		6903 WOERNER FARMS, LLC	Check	No	309.06
<i>Purchase Order #:</i> 0		<i>Voucher #:</i> 175838	<i>Invoice #:</i> 390264		105.00
<i>Invoice Description:</i> 1 PLLT CNTIPD SOD 001-410-620 RPR/MAINT GROUNDS				105.00	
<i>Purchase Order #:</i> 0		<i>Voucher #:</i> 175839	<i>Invoice #:</i> 390512		105.00
<i>Invoice Description:</i> 1 PLLT CNTIPD SOD 001-410-620 RPR/MAINT GROUNDS				105.00	
<i>Purchase Order #:</i> 0		<i>Voucher #:</i> 175840	<i>Invoice #:</i> 390893		105.00
<i>Invoice Description:</i> 1 PLLT CNTIPD SOD 001-410-620 RPR/MAINT GROUNDS				105.00	
<i>Purchase Order #:</i> 0		<i>Voucher #:</i> 176252	<i>Invoice #:</i> 11853		-302.94
<i>Invoice Description:</i> CRDT- ST AUGSTN PLLTS 001-410-620 RPR/MAINT GROUNDS				-302.94	
<i>Purchase Order #:</i> 0		<i>Voucher #:</i> 176253	<i>Invoice #:</i> 388355		297.00
<i>Invoice Description:</i> 2 PLLTS ST AUGSTN SOD 001-410-620 RPR/MAINT GROUNDS				297.00	
**** 12/17/2025		659 XEROX BUSINESS SOLUTIONS SOUTHEAST	Check	No	143.80
<i>Purchase Order #:</i> 0		<i>Voucher #:</i> 175657	<i>Invoice #:</i> IN3710025		121.64

ACCOUNTS PAYABLE CHECK REGISTER

Check Register for 12/4/2025 to 12/17/2025 & Check Numbers 0 to 2147483647

Cash Account 001-000-011

Check Number	Check Date	Vendor Number / Name	Payment Type	EPay	Amount (\$)
<i>Invoice Description:</i> 08/01-10/31/25 COPIER					
		001-100-516 SUPPLIES/OPERATING			121.64
<i>Purchase Order #:</i>	0	<i>Voucher #:</i> 175658	<i>Invoice #:</i> IN3715503		22.16
<i>Invoice Description:</i> 10/29-11/28/25 COPIER					
		001-030-516 SUPPLIES/OPERATING			22.16
*****	12/17/2025	6191 XEROX CORPORATION	Check	No	13.18
<i>Purchase Order #:</i>	0	<i>Voucher #:</i> 175659	<i>Invoice #:</i> 024616671		13.18
<i>Invoice Description:</i> 09/30-10/30/25 COPIER					
		001-110-516 SUPPLIES/OPERATING			13.18
Check Run 8198 Check Total					\$711,379.78
Check Run 8198 Update Only					\$0.00
Check Run 8198 Total					\$711,379.78

Check Run: 8200					
*****	12/17/2025	769 GULF COAST MEDIA PAYMENT SERVICES	Check	No	404.52
<i>Purchase Order #:</i>	0	<i>Voucher #:</i> 176258	<i>Invoice #:</i> 515906		404.52
<i>Invoice Description:</i> PLNNING CMSSN AD					
		001-030-612 PROFESSIONAL FEES			404.52
Check Run 8200 Check Total					\$404.52
Check Run 8200 Update Only					\$0.00
Check Run 8200 Total					\$404.52

Check Run: 8201					
*****	12/17/2025	7007 AT WORK UNIFORMS	Check	No	697.62
<i>Purchase Order #:</i>	0	<i>Voucher #:</i> 176259	<i>Invoice #:</i> 173036A		697.62
<i>Invoice Description:</i> SHRTS/ JCKTS					
		001-010-540 UNIFORMS			697.62
Check Run 8201 Check Total					\$697.62
Check Run 8201 Update Only					\$0.00
Check Run 8201 Total					\$697.62

Check Run: 8204					
*	*****	1520 ORANGE BEACH AUTO & MARINE	Check	No	224.38
<i>Purchase Order #:</i>	0	<i>Voucher #:</i> 174954	<i>Invoice #:</i> 77046		217.77
<i>Invoice Description:</i> #491 HUB KIT/ BRNG KIT/ TOOL					
		001-175-622 RPR/MAINT VEHICLES			217.77
<i>Purchase Order #:</i>	0	<i>Voucher #:</i> 174955	<i>Invoice #:</i> 77047		6.61
<i>Invoice Description:</i> #491 BOLTS/ WSHRS					
		001-175-516 SUPPLIES/OPERATING			6.61
Check Run 8204 Check Total					\$224.38
Check Run 8204 Update Only					\$0.00
Check Run 8204 Total					\$224.38

Check Run: 8205					
------------------------	--	--	--	--	--

ACCOUNTS PAYABLE CHECK REGISTER

Check Register for 12/4/2025 to 12/17/2025 & Check Numbers 0 to 2147483647

Cash Account 001-000-011

Check Number	Check Date	Vendor Number / Name	Payment Type	EPay	Amount (\$)
*****	12/17/2025	8450 THE GREEN-SIMMONS COMPANY, INC.	Check	No	19,557.55
	Purchase Order #: 0	Voucher #: 176467	Invoice #: 6 - FINAL		19,557.55
	Invoice Description: SR CTR ROOF FINAL				
	001-601-731	ADMIN CAPITAL PROJECTS			19,557.55
*****	12/17/2025	8672 WIREGRASS CONSTRUCTION COMPANY, INC.	Check	No	881,486.65
	Purchase Order #: 0	Voucher #: 176468	Invoice #: 9A		475,800.46
	Invoice Description: MLTI-USE TRL S2 TO 10.31.25				
	001-611-755	SIDEWALK EAST CANAL			475,800.46
	Purchase Order #: 0	Voucher #: 176469	Invoice #: 10		17,147.93
	Invoice Description: MLTI-USE TRL S1 TO 10.31.25				
	001-611-755	SIDEWALK EAST CANAL			17,147.93
	Purchase Order #: 0	Voucher #: 176470	Invoice #: 10A		388,538.26
	Invoice Description: MLTI-USE TRL S2 TO 11.30.25				
	001-611-755	SIDEWALK EAST CANAL			388,538.26
				Check Run 8205 Check Total	\$901,044.20
				Check Run 8205 Update Only	\$0.00
				Check Run 8205 Total	\$901,044.20

Description	Count	Amount (\$)
ACH	0	\$0.00
Bank of America	0	\$0.00
Check	249	\$1,616,407.04
Strategic Payment Services	0	\$0.00
Wells Fargo	0	\$0.00
Paymode X	0	\$0.00
Update Only	0	\$0.00
GRAND TOTAL	249	\$1,616,407.04

* Denotes Check Numbers that are out of sequence.

The above listed checks are hereby approved for check signing

Authorized Signatures:

Note:

(Date)

(Date)

(Date)

(Date)



**REGULAR CITY COUNCIL MEETING
DECEMBER 16, 2025**

Departments: City Clerk

Description of Topic: Resolution approving the Fiscal Year 2026 Budget for the City of Orange Beach, including the transfer of special revenue funds to general fund for special revenue fund projects.

Background/Description:

Action Options/Recommendation:

Source of Funding (if applicable):

ATTACHMENTS:

1. 12-16-25 25-xxx Approve FY2026 Budget
2. 2026 Final Budget

RESOLUTION NO. 25-xxx

**A RESOLUTION APPROVING THE FISCAL YEAR 2026 BUDGET FOR
THE CITY OF ORANGE BEACH, INCLUDING THE TRANSFER OF
SPECIAL REVENUE FUNDS TO GENERAL FUND FOR
SPECIAL REVENUE FUND PROJECTS**

BE IT RESOLVED BY THE CITY COUNCIL OF THE CITY OF ORANGE BEACH, ALABAMA, AS FOLLOWS:

1. That the budget for the City of Orange Beach for the Fiscal Year 2026 consisting of pages 1-62 (attached Exhibit A) is approved and adopted by the City Council;
2. That the aforementioned budget includes the transfer of \$403,000 of Special Revenue Funds to the General Fund to help pay the cost of the various Special Revenue Fund projects; and
3. That this Resolution shall become effective immediately upon its adoption.

ADOPTED THIS 16th DAY OF DECEMBER, 2025.

Renee Eberly
City Clerk

C E R T I F I C A T E

I, Renee Eberly, City Clerk of the City of Orange Beach, Alabama, do hereby certify that the foregoing is a true and correct copy of Resolution No. 25-xxx, which was duly and legally adopted at a regular meeting of the City Council on December 16, 2025.

City Clerk

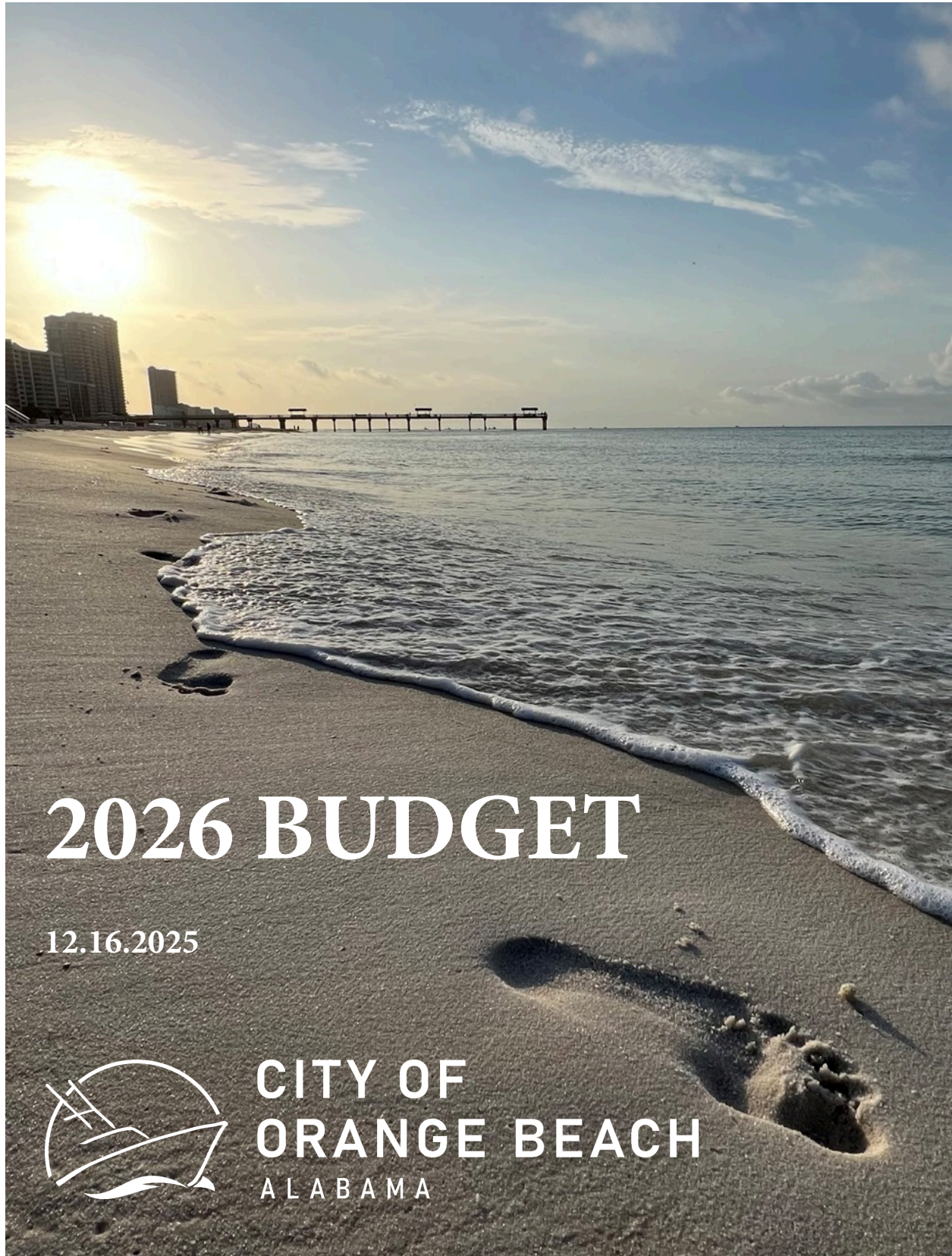

2026 BUDGET

12.16.2025



**CITY OF
ORANGE BEACH**
ALABAMA

CITY OF ORANGE BEACH, ALABAMA
2026 Budget
Table of Contents

Memo From City Administrator	1
General Fund Operating Comparison	2
Enterprise Fund Comparison	3
Capital Request	4
Debt Schedule	5
Revenues & Transfers	6-9
Expenditures by Department	10-62

Administration		Public Works		Expect Excellence	
Department Memo	10-11	Department Memo	30	Department Memo	45-46
Budget Request	12	Budget Request	31-33	Budget Request	47
Court		Parks & Recreation		Performing Arts	
Department Memo	13-14	Department Memo	34-37	Budget Request	48
Budget Request	15	Budget Request	38		
Finance		Sportsplex		Coastal Resources	
Department Memo	16	Budget Request	39	Department Memo	49-51
Budget Request	17			Budget Request	52
Community Development		Pool		Sewer	
Department Memo	18-19	Budget Request	40	Department Memo	53-54
Budget Request	20			Budget Request	55
Police		Golf		Refuse	
Department Memo	21-23	Budget Request	41	Budget Request	33
Budget Request	24				
Corrections		Sr. Center		Event	
Budget Request	25	Budget Request	42	Department Memo	56-57
				Budget Request	58
Communications		Tennis/Pickleball		Art	
Budget Request	26	Budget Request	43	Department Memo	59
				Budget Request	60
Fire		Fitness Center		Library	
Department Memo	27-28	Budget Request	44	Department Memo	61-62
Budget Request	29				



To: Mayor & City Council
From: Ford Handley, City Administrator/Finance Director
Date: December 15, 2025
Subject: 2026 Budget Memo

I have attached the full requested budget for the City of Orange Beach Fiscal Year 2026 for the period beginning January 1, 2026, and ending December 31, 2026. This budget includes departmental memos highlighting the scope and details of their operations. We are excited to be upgrading to new financial software for 2026. This will allow internal departments to operate more efficiently and will provide more transparency in our financial reporting to City Council and the public.

The General Fund operating budget total is \$79,646,219. This includes the proposed increases in pay from the salary study, citywide health insurance, the Wharf warrant, general operating expenses, and general fund debt. This also includes transferring 2% of lodging tax revenue to the Orange Beach School Board to fund city school operations in the amount of \$8,600,000. This is a 7% increase in expenses from the previous year. The City has consistently come in under budget in previous years.

Actual major revenues for 2025 are expected to be around \$84,000,000; citywide revenues are expected to total \$112,000,000. Projected revenue for 2026 is expected to remain steady; therefore, major revenues in the General Fund are budgeted at \$80,000,000, and citywide revenues are budgeted at \$111,567,790. This number includes \$9,196,290 in grant funds relating to capital projects. The entire budget, including all capital expenses, totals \$129,503,640.

Overall new and replacement capital for the City totals \$36,023,391. This includes \$7,000,000 for phase one of the new pool. A couple highlights of the proposed budget include completing both the pickleball courts and citywide multi-modal path project. A new FEMA-funded safe room, fire training building, fire drill field improvements, annual capital replacements, and annual street repaving are also included.

The City is expected to end the year with approximately \$120,000,000 in liquid assets. \$89,000,00 is currently held in investment accounts, and the remaining \$31,000,000 is in the General Fund checking account. Of the investment accounts, \$20,000,000 is set aside for our hurricane reserve.

I am confident that the City remains in a very strong financial position barring any natural disasters or substantial new projects. If one of these situations were to occur, keep in mind the City continues to hold a AA+ bond rating.

Ford Handley
City Administrator/Finance Director
fhandley@orangebeachal.gov

General Fund Operating Comparison

	25 Budget	26 Budget	Inc/(Dec)
Admin	6,219,593	6,648,370	428,777
CD	2,006,407	2,390,846	384,440
Coastal Resources	3,060,699	3,307,865	247,166
Communications	756,282	825,118	68,836
Corrections	896,447	898,903	2,456
Court	436,806	540,614	103,808
Expect Excellence	2,839,520	2,901,794	62,274
Finance	1,607,670	1,513,258	(94,412)
Fire	11,292,278	12,528,069	1,235,791
Landscape	1,493,689	1,424,037	(69,652)
P&R	534,387	877,845	343,458
Sportsplex	1,937,654	2,345,290	407,636
Pool	665,264	705,807	40,542
Sr. Center	338,430	342,873	4,442
Golf	797,255	898,332	101,076
Tennis/Pickleball	0	271,697	271,697
Fitness Center	1,123,320	952,085	(171,235)
Performing Arts	925,287	831,936	(93,351)
Police	8,989,807	9,819,037	829,230
Street	3,428,064	3,686,422	258,358
Health Insurance	5,650,000	6,300,000	650,000
School Funding	8,800,000	8,600,000	(200,000)
Wharf Agreement	2,500,000	2,500,000	0
GF Debt	7,564,812	8,536,022	971,210
GF Operating Expenses	73,863,670	79,646,219	5,782,549

Enterprise Fund Comparison

	24 Budget	25 Budget	Inc/(Dec)
Library	750,000	846,276	96,276
Refuse Revenue	2,750,000	2,755,000	5,000
Refuse Expenses	3,556,347	3,928,789	372,442
Refuse Capital	364,000	235,000	(129,000)
Surplus (deficit)	(1,170,347)	(1,408,789)	377,442
Sewer Revenues	7,200,000	7,955,000	755,000
Sewer Expenses	4,520,518	5,007,699	487,181
Sewer Debt	2,001,100	2,002,045	945
Sewer Capital	658,000	2,163,000	1,505,000
Surplus (deficit)	20,382	(1,217,744)	(1,238,126)
Event Revenues	200,000	142,000	(58,000)
Event Expenses	1,016,186	692,463	(323,723)
Event Capital	81,500	0	(81,500)
Surplus (deficit)	(897,686)	(479,720)	(347,223)
Art Revenue	648,500	730,000	81,500
Art Expenses	1,140,217	1,403,453	263,236
Art Capital	250,000	0	(250,000)
Surplus (deficit)	(741,717)	(673,453)	68,264
Total Enterprise Revenue	10,798,500	11,582,000	783,500
Total Enterprise Expense	14,337,868	16,278,725	1,940,857

2026 CAPITAL REQUEST

Description	Expense	Reimbursement	Notes
ADMIN CAPITAL EQUIPMENT			
ADMIN CAPITAL PROJECTS	1,600,000		Land acquisition(\$2M) , Old Finance Reno(\$1.5M), Veterans Memorial addition of Space Force(\$100k)
SCHOOL CAPITAL			
HAZARD MITIGATION SAFE ROOM	6,000,000	5,400,000	Grant Management, Architect Design, Engineering, Bid Specs
PERFORMING ARTS CAPITAL			
CITYWIDE RENOVATIONS	400,000		Citywide Cameras, and city sign redesign
NEW CIVIC CENTER	700,000		Building Design
COURT CAPITAL EQUIPMENT			
FINANCE CAPITAL EQUIP			
POLICE STATION CONSTRUCTION			
POLICE CAPITAL EQUIPMENT	1,550,500	1,025,000	New radios(\$1.212M -\$1M Grant), Command Truck(\$75k), 2 replace Tundra(\$92k), k9(\$25kGrant), Indoor Drone(\$30k), Pole Camera(\$25k), Golf Cart(\$12k), 3 Rams (\$105k)
FEMA PORT SECURITY POLICE GRANT			
CORRECTIONS CAPITAL EQUIP			
COMMUNICATIONS CAPITAL	90,000		Dispatch Console and Radio Console
FIRE STATION RENOVATION	5,000,000		New training/surf rescue building (\$2M), Drill Field Renovation(\$3M)
FIRE GRANT	1,000,000	1,000,000	AFG- SCBA for Fire Department
FIRE CAPITAL EQUIPMENT	1,467,810		Brush 2(\$85k), 1 replacement vehicle(\$60K), Lifeguard tower(88k),2 Lucas Device(43k), 3UTVs (\$75k),2 Zoll(\$116k), 2 Ambulance(\$1M)
ROADWAYS/PAVING/RESURFACE	1,500,000		Paving plus Jubilee Point and Bay Circle Extension
STREET CAPITAL EQUIPMENT	355,000		Skid Steer(\$110k), Dump Truck(\$205k), Versa Trac(\$40k)
WOLF BAY BRIDGE			
REC TRAIL PJT			No current project.
POWERLINE ROAD	39,000		Project designed and permitted if Council moves forward in future
JUBILEE POINT ROAD IMPROVEMENT			
RECREATION CTR COMPLEX	613,000		Parking Lot Pave(\$320k), Court Cabana(\$28k), Court Resurface(\$70k), 4 New Courts(\$875k) , Replace lights(\$195k)
EXPECT E EQUIPMENT	90,000		ADA Van
EXPECT E CAPITAL			
PAC CAPITAL EQUIPMENT	100,000		LED Screen Replacements
SPORTSPLEX	257,000		Turf fields(\$500k) , Replace '06 Truck(\$50k), Repaint Plex(\$90k) , Replace Equip(\$147k), Fans in Baseball/Softball (\$60k)
POOL	7,000,000		Pool Phase 1
PICKLEBALL	1,250,000		
WATERFRONT PARK	243,000		Replace Pavilion/Restroom Metal Roofs(\$120k), Kids Park surface reseal(\$23k), Shade Structure(\$100k)
SR. CENTER			
GOLF COURSE	190,000		Golf Carts(\$160k), Working Carts(\$30k)
CONTORNO PARK	400,000		Develop Contorno Lake Park(\$400k)
P & R CAPITAL EQUIPMENT	50,000		Site improvements: picnic tables, benches, bike racks etc(\$50k)
ART CENTER			
COASTAL FACILITIES	75,000		Beach monitoring (\$55k) and beach tilling (\$20k)
TAP SIDEWALK GRANT			
SIDEWALK CANAL	1,500,000		Wilson to Bay La & Project Management
LANDSCAPE CAPITAL	60,000		Truck replacement (\$60k)
COMMUNITY DEVELOPMENT CAPITAL EQUIP	90,000		2 replacement trucks
CITY TRAFFIC IMPROVEMENTS	550,000		Upgrade traffic detection cameras and signal operations citywide, Culvers/Wharf light (\$350k)
COASTAL RESOURCE CAPITAL EQUIP	120,000		Replace '15 Truck(\$50k), Replace '14 Flatbed(\$70k)
GOMESA WATERWAY ENHANCEMENT	-	-	Funds have already been received for grant. Grant closed.
SEA TURTLE (RESTORE)	256,700	1,318,000	Project will be complete and funds will be reimbursed 100%
COASTAL WILDLIFE CENTER	-	-	Project will be completed in 2025 and all funds will be reimbursed.
SHOOTING RANGE	375,000		Rifle Range (\$375k) Building moved into 2027
WATERFRONT SHORELINE PROJECT	230,000		Extension of the boardwalk from behind the Art Center to connect to the trail- no grant funds
ROSEMARY DUNES CABINS	123,000		Glamping office/laundry- funding is the balance of donations from Brett Robinson/Young Family
NFWF MARINE DEBRIS	-	-	Grant closed in 2025.
PPBEP GREENHOUSE PROJECT	57,656	57,565	Funds will be 100% reimbursed.
ADEM 319 GRANT	50,000	50,000	WWLC parking and drainage
NRDA MARINE DEBRIS GRANT	195,725	195,725	NRDA Marine Debris Grant- begins April 2025. (\$978,640 / 5 years= \$195,728 per year. Only 9 months in year one = \$146,796)
OB STORMWATER _ RESTORE	150,000	150,000	Bear Point
SEWER PLANT UPGRADES			
SEWER GROUND UPGRADES	2,026,000		Russian Rd (\$736k), Hwy 161 Sinkhole(\$55k), Wolf Bay Lift (\$85k), Plant Diffusers(\$175k), CR 4 lift (\$475k), Survey, design 5MGD Expansion (\$500K)
SEWER CAPITAL EQUIPMENT	137,000		Truck replacement (\$52k), 4in Godwin OPump(\$85k)
REFUSE CAPITAL	132,000		Vacuum \$82,000 2 ROW UTV \$50,000 4
EVENT BUILDING UPGRADES			Stage Replacement(\$75k), Video Replacement(\$50k), Sidewalk Replace(\$30k)
EVENT CAPITAL EQUIPMENT			
TOTAL CAPITAL EQUIPMENT AND PROJECTS	36,023,391	9,196,290	

Debt Payments by Year												
	SEWER	GENERAL	SCHOOL	GENERAL	GENERAL	S47%G53%	GENERAL	GENERAL				
YEAR	2006/2012	2021	2022A	2022B	2007B/2013	2009	2010A	2010B	TOTAL	SEWER	GENERAL	YEAR
2011	1,049,925				393,975	2,667,082	259,035	165,150	4,535,167	2,303,454	2,231,713	2011
2012	1,049,925				393,975	2,693,430	259,035	165,150	4,561,515	2,315,837	2,245,678	2012
2013	895,431				151,858	2,925,868	259,035	165,150	4,397,342	2,270,589	2,126,753	2013
2014	1,046,088				282,258	3,085,805	259,035	165,150	4,838,335	2,496,416	2,341,919	2014
2015	1,679,538				386,344	1,819,705	1,299,452	1,008,483	6,193,521	2,534,799	3,658,722	2015
2016	1,682,563				1,457,950	1,826,142	1,396,790	1,082,767	7,446,211	2,540,849	4,905,362	2016
2017	1,679,913				1,462,250	1,759,830	1,399,607	1,088,646	7,390,245	2,507,033	4,883,212	2017
2018	2,076,971				1,478,183	1,431,705	1,402,902	1,087,504	7,477,265	2,749,872	4,727,393	2018
2019	2,114,588				1,464,100	1,597,194	1,401,768	1,091,613	7,669,263	2,865,269	4,803,994	2019
2020	2,119,192				1,464,700		116,803	91,000	3,791,695	2,119,192	1,672,503	2020
2021	222,699	1,790,854			1,461,425				3,474,978	222,699	3,252,279	2021
2022	485,667	3,046,212	795,667	62,292	1,464,500				5,854,338	485,667	5,368,671	2022
2023	2,006,143	3,046,667	3,660,615	409,100					9,122,525	2,006,143	7,116,382	2023
2024	2,001,100	3,046,667	3,626,936	369,597					9,044,299	2,001,100	7,043,200	2024
2025	1,998,077	3,045,733	3,592,738	1,949,930					10,586,479	1,998,077	8,588,402	2025
2026	2,002,045	3,044,000	3,558,014	1,931,408					10,535,467	2,002,045	8,533,422	2026
2027	2,002,062	3,044,800	3,522,755	1,912,610					10,482,226	2,002,062	8,480,164	2027
2028	2,002,907	3,046,267	3,486,953	1,893,530					10,429,656	2,002,907	8,426,749	2028
2029	2,000,434	3,044,933	3,450,599	1,874,164					10,370,131	2,000,434	8,369,697	2029
2030	2,005,562	3,044,133	3,413,686	1,854,510					10,317,891	2,005,562	8,312,329	2030
2031		3,045,400	3,376,204	1,834,561					8,256,165		8,256,165	2031
2032		3,043,533	3,338,145	1,814,314					8,195,993		8,195,993	2032
2033		3,045,200	3,299,500	1,793,765					8,138,465		8,138,465	2033
2034		3,045,133	3,260,260	1,772,908					8,078,302		8,078,302	2034
2035		3,044,933	3,220,415	1,751,740					8,017,089		8,017,089	2035
2036		3,044,467	3,179,957	1,730,255					7,954,679		7,954,679	2036
2037		3,045,267	3,138,876	1,708,449					7,892,592		7,892,592	2037
2038		3,042,133	3,097,162	1,686,317					7,825,612		7,825,612	2038
2039		3,043,400	3,054,806	1,663,854					7,762,060		7,762,060	2039
2040		3,043,733	3,011,797	1,641,055					7,696,586		7,696,586	2040
2041		2,028,000	2,968,127	1,617,915					6,614,042		6,614,042	2041
2042			2,923,783	1,594,430					4,518,213		4,518,213	2042

2026 Budget Totals

Department	2025 Budget	2026 Budget	Inc/(Dec)
001-000-200 AD VALOREM TAXES	6,500,000	7,000,000	500,000
001-000-201 BEER TAXES	600,000	600,000	0
001-000-202 WINE TAXES	60,000	60,000	0
001-000-203 GASOLINE TAX	90,000	90,000	0
001-000-204 FRANCHISE TAX	1,600,000	1,800,000	200,000
001-000-205 SALES TAX	18,600,000	19,500,000	900,000
001-000-206 TOBACCO TAX	50,000	50,000	0
001-000-207 LODGING TAX	36,000,000	43,000,000	7,000,000
001-000-208 USE TAX	2,000,000	2,500,000	500,000
001-000-209 RENTAL TAX	500,000	600,000	100,000
001-000-226 BUSINESS LICENSE	3,000,000	3,700,000	700,000
001-000-228 BUILDING PERMITS	1,000,000	1,100,000	100,000
Major Revenue Total	70,000,000	80,000,000	10,000,000
001-000-231 IMPACT FEE P & R	100,000	100,000	0
001-000-232 IMPACT FEE FIRE	100,000	100,000	0
001-000-233 IMPACT FEE POLICE	50,000	50,000	0
001-000-234 IMPACT FEE TRANS	0	0	0
001-000-235 IMPACT FEE LIBRARY	0	0	0
001-000-237 OPIOID SETTLEMENT	0	50,000	50,000
001-000-251 ADEM (COASTAL MGT)	37,500	37,500	0
001-000-256 STATE PARK REIMBURSEMENT	60,000	80,000	20,000
001-000-257 CVB SPORTSPLEX REIMBURSEMENT	200,000	0	(200,000)
001-000-260 FIN INSTI EXCISE TAX	75,000	75,000	0
001-000-261 OIL PRODUCTION PRIV TAX	1,000	1,000	0
001-000-262 2% TAX ON ABC STORE SALES	30,000	30,000	0
001-000-272 TAP SIDEWALK GRANT	387,200	387,200	0
001-000-273 CANAL ROAD (RESTORE)	0	0	0
001-000-275 SEA TURTLE (RESTORE)	1,318,000	1,318,000	0
001-000-277 WILDLIFE REHAB CENTER (RESTORE)	200,000	0	(200,000)
001-000-280 HAZARD MITIGATION SAFE ROOM GRANT	641,731	5,400,000	4,758,269
001-000-281 P&R SALES REVENUE	265,000	265,000	0
001-000-282 P&R SALES TAX	26,500	26,500	0
001-000-283 P&R SALES TAX PAID	-20,000	-20,000	0
001-000-285 FEMA PORT SECURITY GRANT POLICE	347,463	0	(347,463)
001-000-290 OTHER GRANTS	4,765,145	2,091,090	(2,674,055)
001-000-301 BOA VARIANCE/APPEAL FEE	1,000	1,000	0
001-000-304 PLANNING APPLICATIONS	45,000	45,000	0
001-000-307 CONTRACTS/SVCI RGTS	855,000	1,000,000	145,000
001-000-310 COPIES	4,000	4,000	0
001-000-311 PERSONNEL SVC REIM	141,000	141,000	0
001-000-313 FINES/RESTITUTIONS	510,000	300,000	(210,000)
001-000-316 GIFTS	30,000	30,000	0
001-000-319 INTEREST EARNED	1,000,000	2,500,000	1,500,000
001-000-325 MISCELLANEOUS INCOME	55,000	55,000	0
001-000-326 COASTAL RESOURCES PROCEEDS	25,000	25,000	0
001-000-327 WWLC FEES	45,000	45,000	0
001-000-328 P&R CONCESSION SALES	295,000	250,000	(45,000)
001-000-330 P&R FACILITY FEES	400,000	600,000	200,000
001-000-332 P&R LESSONS	40,000	40,000	0
001-000-334 P&R PROGRAM FEES	85,000	100,000	15,000

2026 Budget Totals

Department	2025 Budget	2026 Budget	Inc/(Dec)
001-000-336 EXPECT EXCELLENCE FEE	145,000	145,000	0
001-000-337 RENTALS - LAND/BLDGS	150,000	200,000	50,000
001-000-338 FIRE EMS REVENUE	375,000	375,000	0
001-000-339 PERFORMING ARTS CENTER	50,000	50,000	0
001-000-340 SURPLUS PROCEEDS	50,000	50,000	0
001-000-341 FESTIVAL REVENUE	30,000	30,000	0
001-000-342 GOLF CART PERMITS	10,000	10,000	0
001-000-343 TENNIS CTR FEES	25,000	25,000	0
001-000-344 WWLC KAYAK RENTAL FEES	0	500	500
001-000-345 SHOOTING RANGE MEMBERSHIP FEES	0	40,000	40,000
001-000-347 SHOOTING RANGE MERCHANDISE FEES	0	30,000	30,000
001-000-363 INSURANCE PROCEEDS	0	2,000,000	2,000,000
001-000-365 SEWER FEE	1,500,000	1,500,000	0
Grant Total	7,659,539	9,196,290	1,536,751
Other GF	6,791,000	10,386,500	3,595,500
Total Other GF	14,450,539	19,582,790	5,132,251
100-000-284 VEHICLE TAGS	25,000	25,000	0
100-000-285 VEHICLE TAX	65,000	125,000	(60,000)
100-000-286 STATE PETRO FEE	2,500	2,500	0
100-000-287 STATE 4 CENT TAX	8,500	8,500	0
100-000-288 STATE 5 CENT TAX	4,500	4,500	0
100-000-289 STATE 7 CENT TAX	15,000	15,000	0
100-000-290 STATE VEHICLE LIC	1,500	1,500	0
100-000-292 AL TRUST FUND DIST	75,000	75,000	0
100-000-297 CT CLK JUD ADMIN FUND	20,000	20,000	0
100-000-298 ABM CONSERVATION FUND	16,000	16,000	0
100-000-300 REBUILD AL GAS TAX	50,000	50,000	0
100-000-319 INTEREST EARNED	10,000	10,000	0
200-000-319 INTEREST EARNED	50,000	50,000	0
Special Revenue	343,000	403,000	(60,000)
403-000-275 SEWER SERVICE FEES	7,200,000	7,200,000	0
403-000-276 SEWER TAP FEES	150,000	600,000	450,000
403-000-319 INTEREST EARNED	100,000	150,000	50,000
403-000-325 MISCELLANEOUS INCOME	5,000	5,000	0
404-000-280 GARBAGE SVC FEES	2,750,000	2,750,000	0
404-000-325 MISCELLANEOUS INCOME	5,000	5,000	0
411-000-275 EVENT RENTAL FEES	100,000	100,000	0
411-000-276 USAGE FEES	32,000	32,000	0
411-000-277 COMM CTR RENTAL FEES	10,000	10,000	0
430-000-275 RENTAL FEES	230,000	300,000	70,000
430-000-280 TICKET SALES	4,500	4,500	0
430-000-281 SALES REVENUE	235,000	240,000	5,000
430-000-282 SALES TAX	23,500	24,000	500
430-000-285 AL COUN ARTS GRANT	2,000	2,000	0
430-000-316 GIFTS	1,500	1,500	0
430-000-325 MISCELLANEOUS INCOME	2,000	2,000	0
430-000-332 LESSONS	85,000	85,000	0

2026 Budget Totals

Department	2025 Budget	2026 Budget	Inc/(Dec)
430-000-334 PROGRAMS	30,000	32,000	2,000
430-000-335 FESTIVALS REVENUE	35,000	39,000	4,000
ENTERPRISE TOTAL	11,000,500	11,582,000	(581,500)
GF Major Revenue	70,000,000	80,000,000	10,000,000
GF Other	6,791,000	10,386,500	3,595,500
Special Revenue	343,000	403,000	60,000
Grant Reimbursement	7,659,539	9,196,290	1,536,751
Enterprise	11,000,500	11,582,000	581,500
Revenue Subtotal	95,794,039	111,567,790	15,773,751

2026 Budget Totals

Department	2025 Budget	2026 Budget	Inc/(Dec)
TRANSFERS			
001-000-805 TRANSFER TO DEBT SVS FUND	10,586,479	10,535,467	(51,012)
001-000-903 TRANSFER TO SPEC REV FUND	343,000	403,000	60,000
001-000-904 TSF TO EVENTS CTR FUND	897,686	479,720	(417,966)
001-000-906 TSF TO WHARF	2,500,000	2,500,000	0
001-000-907 TSF TO ARTS	741,717	673,453	(68,264)
001-000-908 TSF TO REFUSE FUND	1,170,347	1,408,789	238,442
001-000-909 CITY HEALTH EXPENSE	5,650,000	6,300,000	650,000
001-000-910 HURR SALLY			0
001-000-911 LIBRARY AID	760,000	846,276	86,276
001-000-913 TSF TO OTHER GOVT	8,800,000	8,600,000	(200,000)
100-550-910 TSF TO GF/GAS TX	90,000	90,000	0
100-550-911 TSF TO GF/FIRE TX	5,000	5,000	0
100-550-914 TSF TO GF/AL TRUST FD	55,000	55,000	0
100-550-918 TSF TO GF/CCJAF	70,000	70,000	0
100-550-919 TSF TO GF/BEACH MOUSE	20,000	20,000	0
TRANSFER TOTALS	31,689,229	31,986,705	297,476
DEBT SERVICE FUND			
200-450-821 2021 GO WARR/INT	1,505,000	1,565,000	60,000
200-450-822 2021 GO WARR/INT	1,541,800	1,481,600	(60,200)
200-450-823 2022A GO WARR/PRIN	2,220,631	2,205,969	(14,662)
200-450-824 2022A GO WARR/INT	1,406,305	1,352,045	(54,260)
200-450-830 2022B GO WARR/PRIN/INT	500,000	1,931,408	1,431,408
403-000-830 SEWER BOND	1,998,077	2,002,045	3,968
Debt Service Total	9,171,813	10,538,067	1,366,254



Orange Beach Administration

Purpose: The City of Orange Beach Administrative Department is based at Orange Beach City Hall and is composed of the City Clerk's Office, Legal Division, Human Resources Division, Procurement Division, executive staff, and supporting administrative staff. The primary purpose of the Administration Department is to serve as a communication bridge between elected officials and the public. The Administration Department provides centralized support for the municipality's daily operations and long-term goals set by the Mayor and City Council.

Hours: Monday-Friday, 8 a.m. to 5 p.m.

Address: 4099 Orange Beach Boulevard

Phone: 251-981-6979

Website: <https://www.orangebeachal.gov>

Staff: 13 full-time employees

Director: City Clerk Renee Eberly

Budget: \$6,648,370 (FY2026)

Reason for 2026 budget increase: New HR software and requirement for all employees to have a city email. Increased workers compensation insurance.

Features:

- The **City Clerk** is a position appointed by City Council to serve as the Custodian of public records for the City of Orange Beach, which includes all minutes, resolutions, ordinances, contracts, and the City's Municipal Code. The City Clerk is required to attend all City Council meetings and is responsible for preparing the agendas and minutes of the City Council meetings. The Clerk oversees all municipal elections, including the administration of candidate statements, ballots, and legal advertising. In addition, the City Clerk is the official custodian of the City's corporate seal and has signature authority, which is required on all ordinances and resolutions and other official documents of the City. The City Clerk's Office is a citywide information and document resource center.
 - Employees: 1 full-time
- The **City Attorney** is a position appointed by City Council to represent the City in all causes in which the City is interested. The City Attorney provides legal counsel to the Mayor, City Council, and other City officials, such as Department Heads, agencies and boards relative to all aspects of City government, including ordinances, contracts, policies, procedure, compliance with state and federal law, claims and collections, enforcement of local ordinances, and real estate matters.
 - Employees: 2 full-time

- **Human Resources** recruits and retains the most qualified, competent, and motivated employees for the City. The city's employee-friendly environment offers competitive wages and a robust benefits package. The City's employees are its most important asset in accomplishing its varied goals and objectives to support the motto, "Life is Better Here."
 - Employees: 4 full-time
- **Procurement** supports all City Departments by sourcing quality goods and services in an ethical, cost-effective, and timely manner while ensuring that Federal and State regulations and City policies and procedures are being followed.
 - Employees: 1 full-time
- Executive and administrative staff at City Hall serve as liaisons between the public and elected officials. Staff also assist with disseminating information back to the public through various forms of communication including press releases, newsletters, City website, social media accounts, and electronic message boards.
 - Employees: 5 full-time

2026 Budget Totals

Department	2025 Budget	2026 Budget	Inc/(Dec)
001 Administration			
001-001-401 SALARIES	1,420,492	1,608,549	188,057
001-001-402 OVERTIME	4,000	4,000	0
001-001-460 RETIREMENT	88,000	120,941	32,941
001-001-470 FICA	104,001	123,360	19,359
001-001-490 SUTA	1,000	1,000	0
001-001-491 INSURANCE/WORK COMP	850,000	950,000	100,000
001-001-507 EQUIPMENT/SMALL	339,000	238,000	(101,000)
001-001-510 GAS/OIL	7,000	7,000	0
001-001-513 SUPPLIES/JANITORIAL	4,000	6,000	2,000
001-001-516 SUPPLIES/OPERATING	40,000	62,000	22,000
001-001-540 UNIFORMS	2,400	5,600	3,200
001-001-605 COMMUNICATIONS	35,000	50,000	15,000
001-001-608 DUES/MEMBERSHIP/SUBSCRIPT	17,000	18,000	1,000
001-001-610 INSURANCE/PTY&LIAB	1,400,000	1,400,000	0
001-001-612 PROFESSIONAL FEES	1,207,700	1,506,420	298,720
001-001-616 RPR/MAINT PLANT/BLDGS	164,000	54,000	(110,000)
001-001-618 RPR/MAINT EQUIPMENT	10,000	10,000	0
001-001-622 RPR/MAINT VEHICLES	10,000	10,000	0
001-001-630 TRAINING/TRAVEL	145,500	148,000	2,500
001-001-635 UTILITIES	35,000	50,000	15,000
001-001-640 MISCELLANEOUS	7,500	10,000	2,500
001-001-641 EMPLOYEE ADVISORY COMM	20,000	20,000	0
001-001-645 AID TO OTHER GOVTS	178,000	178,000	0
001-001-650 EXHIBITIONS & PROMOTIONS	130,000	67,500	(62,500)
001 Administration Subtotal	6,219,593	6,648,370	428,777



Orange Beach Municipal Court

Purpose: The Orange Beach Municipal Court has jurisdiction over misdemeanor traffic, non-traffic and municipal ordinances violations that occur within the city limits or within the police jurisdiction of the City of Orange Beach.

Hours: Monday-Friday, 8:00 a.m. to 5 p.m.

Phone: 251-981-2444

Website: <https://www.orangebeachal.gov/195/Municipal-Court>

Staff: 4 full-time employees

Director: Pamela Davis

Budget: Revenue: (2025 Revenue thru 10/29/25: \$363,523.74)
Expense: \$540,614

Reason for 2026 budget increase: Court Renovation (see below)

Features:

- The Orange Beach Municipal Court serves as the Judicial Branch of our Municipality. Court is held twice monthly, generally the second Wednesday and fourth Tuesday of each month.
- Our court staff includes Court Director Pam Davis, Magistrates Christy Palmer, Jill Weatherford and Johnnie Sue Gilbert, Judge Michael Dasinger, and Prosecutor Spencer Davis.
- The Municipal Court Judge presides over court proceedings, including misdemeanor traffic, non-traffic and municipal ordinance violations. The Judge also conducts the Initial Appearance Hearings as required for individuals arrested who cannot post bond within 72 hours of their arrest.
- On behalf of the City of Orange Beach, the Municipal Court Prosecutor handles the prosecution of persons charged with misdemeanor traffic, non-traffic and municipal ordinance violations. The Prosecutor also manages cases appealed from the Municipal Court to the Circuit Court of Baldwin County.
- The Court Director and Magistrates are responsible for the daily operations of the court. Our responsibilities are both judicial and administrative in accordance with state rules and laws. Magistrates hold positions of public trust. To maintain the integrity of court processes, Magistrates are required to uphold confidentiality for all cases filed with the court. The Magistrates are on-call 24/7 as needed to conduct various hearings and for consultation with our law enforcement officers.
- Additionally, the Court offers a Defensive Driving School for young drivers and adults. This option provides an alternative to convictions for moving offenses.

We offer two courses, taught by our National Safety Council certified officers. These courses are assigned to offenders from other municipal courts in the area, and are available to the public for a small fee.

Court Renovation:

The Municipal Court complex was built in 2002. All flooring is original. My proposal is to replace all flooring with a combination of polyaspartic coating and plank flooring, and also replace the wooden benches with chairs. In the Magistrate's admin office, two of the workstations are 30+ years old. All can be funded by the court's discretionary funds which are summarized below.

Court Clerks Judicial Admin Fund (12-19-310 Code of Alabama)

Ten dollars (\$10) of each fee in municipal court shall be retained by the presiding municipal judge or the municipal court clerk for the operation of the municipal court and are distributed to the municipality for the operation of the municipal courts.

Disposition of Funds (12-19-312 Code of Alabama)

(b) The fee allocated for the court clerk's fund shall be expended at the discretion of the clerk, to support the functions of the office of the clerk.

Corrections Fund (11-47-7.1, Code of Alabama)

These funds are allocated exclusively for the operation, maintenance and equipping of the municipal court complex and jail which includes renovation expenses. Currently, these funds are split each month 50/50 with the jail to offset their operating expenses.

2026 Budget Totals

Department	2025 Budget	2026 Budget	Inc/(Dec)
010 Court			
001-010-401 SALARIES	255,785	259,266	3,481
001-010-402 OVERTIME	19,000	13,000	(6,000)
001-010-460 RETIREMENT	17,500	20,420	2,920
001-010-470 FICA	21,021	20,828	(193)
001-010-490 SUTA	100	100	0
001-010-507 EQUIPMENT/SMALL	9,000	3,000	(6,000)
001-010-510 GAS/OIL	200	200	0
001-010-513 SUPPLIES/JANITORIAL	5,000	5,500	500
001-010-516 SUPPLIES/OPERATING	9,000	9,500	500
001-010-540 UNIFORMS	800	800	0
001-010-605 COMMUNICATIONS	2,700	3,200	500
001-010-608 DUES/MEMBERSHIP/SUBSCRIPT	3,200	3,300	100
001-010-612 PROFESSIONAL FEES	81,000	75,000	(6,000)
001-010-616 RPR/MAINT PLANT/BLDGS	10,000	125,000	115,000
001-010-622 RPR/MAINT VEHICLES	1,000	0	(1,000)
001-010-630 TRAINING/TRAVEL	1,500	1,500	0
010 Court Subtotal	436,806	540,614	103,808



Orange Beach Finance Department

Purpose: The Finance Department strives to provide the citizens, employees, and customers of the City of Orange Beach with quality financial management, financial reporting, and cost-effective acquisition of goods and services for the City consistent with local, state, and federal laws and governmental accounting and regulatory requirements.

Hours: Monday through Friday, 7 a.m. to 5 p.m.

Phone: 251-981-6096

Website: <https://www.orangebeachal.gov/267/Finance-Department>

Staff: 10 full-time employees

Director: Ford Handley

Budget: \$1,513,258

Change for 2026 budget: Finance is requesting either another full time accountant or part time revenue officer to assist with delinquencies.

Features:

- Business Licenses are issued by the Finance Department for new businesses as needed and annually, each January, for ongoing businesses. Renewal notices are mailed; however, it is the responsibility of the business to meet the renewal deadline, whether they have received the renewal notice or not. Anyone doing business or soliciting for business in the City of Orange Beach must have a Business License.
- The Finance Department collects various local taxes in Sales (general, automotive, machine/agriculture), Lodging, Use (general, automotive, machine/agriculture), and Lease (General, Auto/Linens, etc.).
- The Finance Department collects the city sewer service fees and manages the financial operations for all departments in the city.
- Finance handles all the revenues, accounts payables, payroll for the City.
- Our budget includes all of the financial software used by all the departments.

2026 Budget Totals

Department	2025 Budget	2026 Budget	Inc/(Dec)
020 Finance			
001-020-401 SALARIES	832,935	970,362	137,427
001-020-402 OVERTIME	1,000	1,000	0
001-020-460 RETIREMENT	59,367	59,367	0
001-020-470 FICA	63,796	74,309	10,513
001-020-490 SUTA	220	220	0
001-020-507 EQUIPMENT/SMALL	25,000	30,000	5,000
001-020-510 GAS/OIL	1,500	1,500	0
001-020-516 SUPPLIES/OPERATING	24,000	24,000	0
001-020-540 UNIFORMS	500	500	0
001-020-605 COMMUNICATIONS	35,000	35,000	0
001-020-608 DUES/MEMBERSHIP/SUBSCRIPT	500	500	0
001-020-612 PROFESSIONAL FEES	517,352	270,000	(247,352)
001-020-616 RPR/MAINT PLANT/BLDGS	15,000	15,000	0
001-020-618 RPR/MAINT EQUIPMENT	750	750	0
001-020-622 RPR/MAINT VEHICLES	750	750	0
001-020-630 TRAINING/TRAVEL	15,000	15,000	0
001-020-635 UTILITIES	15,000	15,000	0
020 Finance Subtotal	1,607,670	1,513,258	(94,412)



Orange Beach Community Development

Purpose: The Community Development Department carries out the following primary functions: City Planning, Building Permits & Inspections, Engineering, Construction Management, Code Enforcement, and Geographic Information Systems.

Hours: Monday through Friday, 8 a.m. to 5 p.m.

Phone: 251-981-2610

Website: <https://www.orangebeachal.gov/176/Community-Development>

Staff: 15 full-time employees

Director: Adam Roberson

Budget: \$2,390,846

Reason for 2026 budget increase:

- The 2026 budget request reflects a 27% increase. This includes a 10% salary increase to address any recommendations that may come from recent compensation study. The increase also accounts for two new staff positions and the necessary equipment to support them. Additional contributors to the budget rise include the purchase of a LiDAR drone to help identify and resolve stormwater issues within the City, as well as professional fees for a consultant to update the zoning code and complete the comprehensive plan.

Staff increase:

- The needs of an Engineering Assistant to provide field and inspection support, as ongoing growth and expanded responsibilities have made the City Engineer's workload—encompassing stormwater management, infrastructure inspections, design work, and compliance—unsustainable without additional help.
- The City needs a City Planner Assistant to support Griffin Powell, whose unsustainable workload—managing all development reviews, zoning compliance, public meetings, and upcoming Comprehensive Plan and Zoning Code updates—now exceeds what a single staff member can handle.

Features:

- The **Planning & Zoning and Code Enforcement Division** Provides assistance to the development community to ensure that future growth and change happens in accordance with policies and ordinances. This includes development review, environmental review, comprehensive long and short-term planning, and stormwater management & transportation planning. Promotes and maintains a safe and desirable living and working environment for Orange Beach residents and business owners. The code enforcement program is proactive in addressing unsightly yards and structures, public nuisances, trash abatement, vacant building monitoring and unpermitted construction.
 - Employees: 4
- The **Building Permitting & Inspections Division** regulates construction development to safeguard and ensure the health and safety of the public. The division provides permits, plan review, and building inspections to ensure compliance with building codes.
 - Employees: 5
- The **Construction Management Division** Manages all city construction projects along with maintaining the city facilities.
 - Employees: 3
- The **Engineering & Geographic Information Systems (GIS) Division** oversees all city engineering functions and infrastructure reviews and all stormwater management. Provides special data and analysis resources for the city's decision makers, staff and citizens. GIS functions include geographic projects, state-of-the-art map preparation and generation, addressing assignment, spatial data collection, development and maintenance.
 - Employees: 3

2026 Budget Totals

Department	2025 Budget	2026 Budget	Inc/(Dec)
030 Community Development			
001-030-401 SALARIES	1,204,741	1,350,254	145,513
001-030-402 OVERTIME	2,000	2,500	500
001-030-460 RETIREMENT	82,000	101,457	19,457
001-030-470 FICA	92,316	103,486	11,170
001-030-490 SUTA	250	250	0
001-030-507 EQUIPMENT/SMALL	43,400	92,600	49,200
001-030-510 GAS/OIL	12,000	12,000	0
001-030-513 SUPPLIES/JANITORIAL	2,500	2,500	0
001-030-516 SUPPLIES/OPERATING	33,500	28,500	(5,000)
001-030-540 UNIFORMS	4,500	5,000	500
001-030-605 COMMUNICATIONS	20,000	25,000	5,000
001-030-608 DUES/MEMBERSHIP/SUBS	32,700	40,000	7,300
001-030-612 PROFESSIONAL FEES	319,500	485,100	165,600
001-030-614 RENTALS	200	200	0
001-030-616 RPR/MAINT PLANT/BLDG	55,300	42,000	(13,300)
001-030-618 RPR/MAINT EQUIPMENT	4,500	4,500	0
001-030-620 RPR/MAINT GROUNDS	1,000	1,000	0
001-030-622 RPR/MAINT VEHICLES	13,500	13,500	0
001-030-630 TRAINING/TRAVEL	47,500	46,000	(1,500)
001-030-635 UTILITIES	35,000	35,000	0
030 Community Development Subtotal	2,006,407	2,390,846	384,440



Orange Beach Police Department

Purpose:

The mission of the Orange Beach Police Department is to create positive relationships through community engagement with a human-focused approach to law enforcement. The department is organized into multiple divisions including, Patrol, Marine, Investigative, Intelligence, Communications, Corrections and Support Services.

History:

Orange Beach Police became its own department in 1993. Prior to 1993, the city had a Department of Public Safety and the department utilized members who were police officers that were also cross-trained to be firefighters/paramedics and vice versa.

Hours: 24 hours a day, 365 days a year
Phone: 251-981-9777
Website: <https://www.orangebeachal.gov/293/Police-Department>
Staff: 94/106 full-time employees, 9 part-time employees
Director: Interim Chief David "Trent" Johnson
Budget: The Police Budget is broken down into Police, Communications and Corrections
Police: \$9,819,037
Communications Division: \$825,118
Corrections Budget \$898,903

2026 budget increases:

Police - Increase of \$829,230

Personnel- \$711,232 (includes salaries, overtime, retirement, FICA and SUTA)

We hired 7 police officers in 2025 and currently have 3 in the pipeline to begin in late 2025, early 2026

Small equipment increase to replace aging equipment

Communications - Increase of \$68,836

- Personnel - Budgeted for full staffing and merit increases
- Professional Fees - Astro/SUA Warranty/Maintenance 2025 payment deferred to 2026 due to billing cycle issues

Corrections - Increase of \$2,456

- Personnel - Adjusted personnel schedules to accommodate an even number of personnel

Features:

- The **Patrol Division** patrols the City to proactively prevent crime and be readily available to respond to calls for service and take reports for crimes committed. Uniform patrol is also responsible for traffic and DUI enforcement providing safe roadways and pedestrian paths for residents and guests.
 - Employees at full staffing: 43
- The **Investigative Division** conducts follow up investigations for all misdemeanor and felony crimes ranging from thefts, domestic violence, frauds, sex crimes and homicides.
 - Employees at full staffing: 8
- The **Intelligence Division** is responsible for gathering, storing, evaluating, and distributing criminal intelligence information. This information is collected for the purpose of identifying criminal patterns, trend developments, identification of suspects, and identifying officer safety issues. The Intelligence Division is also composed of the department's digital forensics investigators who are responsible for extracting and analyzing data from digital devices to aid in the identification, apprehension and prosecution of suspects.
 - Employees at full staffing: 5
- The **Communications Division** is the first point of contact between the need for law enforcement and the officers responding. They are trained to empathetically obtain the pertinent information, to include urgency and safety issues, and relay it timely and accurately for responding officers.
 - Employees at full staffing: 9
- The **Marine Division's** primary responsibility is to patrol our waterways to ensure boaters and vessel passengers are safe. They also enforce State law and city ordinances within the police jurisdiction on the water.
 - Employees at full staffing: 9
- The **Support Services Division** is composed of corrections, training, procurement, animal control, and support services technicians. Corrections is responsible for the safe and secure housing of pre-sentenced arrestees, ranging from misdemeanors to felonies (later transported to Baldwin County Jail) as well as sentenced inmates. Training is responsible for coordinating the necessary training all sworn law enforcement is required to have each year as well as our in house requirements. Animal Control is responsible for the safe capture and housing of a variety of domesticated animals as well as the enforcement of our animal control ordinances. Support Services are a catch all group responsible for a variety of tasks to include our school zone traffic, fleet management transportation and are extensively involved with our community outreach programs.
 - Employees at full staffing: 23

- The **Administrative Division** is composed of office, janitorial, and IT staff, as well as the chief and deputy chiefs. Office, janitorial and IT staff ensure that the day to day operations of the department run smoothly. The chief is responsible for ensuring the mission, vision and value of the department align with community values. The deputy chiefs are responsible for ensuring that the mission, vision and values are implemented at every level and in all operations of the department.
 - Employees at full staffing: 9

2026 Budget Totals

Department	2025 Budget	2026 Budget	Inc/(Dec)
100 Police			
001-100-401 SALARIES	5,685,153	6,123,787	438,634
001-100-402 OVERTIME	455,000	550,000	95,000
001-100-460 RETIREMENT	365,000	500,534	135,534
001-100-470 FICA	469,722	510,545	40,823
001-100-490 SUTA	1,300	2,541	1,241
001-100-507 EQUIPMENT/SMALL	391,165	456,145	64,980
001-100-510 GAS/OIL	270,000	260,000	(10,000)
001-100-516 SUPPLIES/OPERATING	120,000	125,000	5,000
001-100-540 UNIFORMS	120,000	125,000	5,000
001-100-605 COMMUNICATIONS	110,000	110,000	0
001-100-608 DUES/MEMBERSHIP/SUBSCRIPT	9,500	9,500	0
001-100-612 PROFESSIONAL FEES	416,967	438,145	21,178
001-100-614 RENTALS	41,000	41,000	0
001-100-616 RPR/MAINT PLANT/BLDGS	70,000	117,000	47,000
001-100-618 RPR/MAINT EQUIP	40,000	40,000	0
001-100-620 RPR/MAINT GROUNDS	50,000	40,000	(10,000)
001-100-622 RPR/MAINT VEHICLES	150,000	150,000	0
001-100-630 TRAINING/TRAVEL	140,000	139,840	(160)
001-100-635 UTILITIES	85,000	80,000	(5,000)
100 Police Subtotal	8,989,807	9,819,037	829,230

2026 Budget Totals

Department	2025 Budget	2026 Budget	Inc/(Dec)
110 Corrections			
001-110-401 SALARIES	507,020	510,000	2,980
001-110-402 OVERTIME	60,000	75,000	15,000
001-110-460 RETIREMENT	36,000	36,000	0
001-110-470 FICA	43,377	44,753	1,376
001-110-490 SUTA	200	300	100
001-110-507 EQUIPMENT/SMALL	10,000	30,900	20,900
001-110-510 GAS/OIL	1,800	1,000	(800)
001-110-513 SUPPLIES/JANITORIAL	3,500	3,500	0
001-110-516 SUPPLIES/OPERATING	88,000	64,500	(23,500)
001-110-540 UNIFORMS	12,000	15,000	3,000
001-110-605 COMMUNICATIONS	26,000	2,600	(23,400)
001-110-608 DUES/MEMBERSHIP/SUBSCRIPT	850	850	0
001-110-612 PROFESSIONAL FEES	45,000	35,000	(10,000)
001-110-616 RPR/MAINT PLANT/BLDGS	44,200	60,000	15,800
001-110-618 RPR/MAINT EQUIPMENT	1,500	2,500	1,000
001-110-622 RPR/MAINT VEHICLES	2,000	2,000	0
001-110-630 TRAINING/TRAVEL	15,000	15,000	0
110 Corrections Subtotal	896,447	898,903	2,456

2026 Budget Totals

Department	2025 Budget	2026 Budget	Inc/(Dec)
120 Communications			
001-120-401 SALARIES	431,655	462,230	30,575
001-120-402 OVERTIME	70,000	95,000	25,000
001-120-460 RETIREMENT	30,000	35,000	5,000
001-120-470 FICA	38,377	42,628	4,251
001-120-490 SUTA	250	270	20
001-120-507 EQUIPMENT/SMALL	35,000	8,800	(26,200)
001-120-516 SUPPLIES/OPERATING	3,500	3,000	(500)
001-120-540 UNIFORMS	9,500	7,500	(2,000)
001-120-605 COMMUNICATIONS	50,000	45,000	(5,000)
001-120-608 DUES/MEMBERSHIP/SUBSCRIPT	3,000	1,500	(1,500)
001-120-612 PROFESSIONAL FEES	65,000	104,190	39,190
001-120-618 RPR/MAINT EQUIPMENT	5,000	5,000	0
001-120-630 TRAINING/TRAVEL	15,000	15,000	0
120 Communications Subtotal	756,282	825,118	68,836



Orange Beach Fire Department

Purpose: The Orange Beach Fire & Rescue Department (OBFR) is dedicated to providing essential emergency response, prevention, and education services to the Orange Beach community with pride, honor, and integrity.

History: Orange Beach Fire became its own department in 1993. Prior to 1993, the city had a Department of Public Safety and the department utilized members who were firefighters and paramedics that were also cross-trained to be police officers and vice versa. In 1993, the fire department was composed of six full-time firefighter/paramedics, which cross-staffed a fire engine and a rescue truck, in addition to the fire chief.

Hours: 24/7 staffing with Admin office hours of Monday-Friday, 8 a.m. to 5 p.m.

Phone: 251-981-6166

Website: <https://www.orangebeachal.gov/169/Fire-Department>

Staff: 91 full-time employees, 42 part-time employees, 26 seasonal employees

Director: Chief Jeff Smith

Budget: \$12,528,069

Reason for 2026 budget increase:

Salaries:

Replacing 9 part time fire fighters with 3 full time fire fighters.

Increasing intern firefighter contracts to sixteen months to maintain full intern staffing throughout the year. Currently, four months of the contract are for recruit school. \$40,000

Salary increases for personnel based on current salary study.

Operating:

Supplies: Increase due to higher costs and the addition of the Training Facility.

Uniforms: Increase in the cost of uniforms as well as uniforms for an honor guard.

Communications: Increase due to additional cellular and tablet devices for apparatus and personnel. In addition, our new, grant funded, Motorola radios have GPS and LTE capabilities requiring a subscription above the normal costs to the County.

- Rentals: Increase is due to overlapping of two intern firefighter classes which requires doubling the sets of rented personal protective equipment from 12 to 24 sets.
- Training/Travel: Increase is due to additional EMT employees wishing to obtain their paramedic licenses.

Features:

- Currently, the department staffs 3 engine companies, 1 truck company, 3 transport units, and a battalion chief. All units are equipped for advanced life support medical care with cardiac monitors, lucas devices, and medications.
- Fire stations are staffed 24 hours a day, seven days a week with minimum daily staffing of 19 personnel.
- Major programs include EMS Transport, Surf Rescue, Hazardous Materials Response, High Angle Rescue, Technical Rescue, and Dive/Water Rescue - with many other programs that support the department's mission.
- The Orange Beach Fire & Rescue Department is the first to respond to all medical emergencies within the city and is the primary emergency transport agency. The department also provides all fire code enforcement activities and plan review services.
- One of 26 regional training centers for the Alabama Fire College hosting multiple certification classes each year, with participation from firefighters across the country. Our RTC also hosts an annual firefighter recruit school hosting our own intern firefighter candidates as well as recruits from other regional and local fire departments. Once complete, the 12 intern firefighters supplement career staffing on each shift, bringing the daily staffing up from 19 to 23 firefighters each day. Currently, 21 of our full time staff received their start in the fire service through our internship program.
- In 2024 the department received an ISO Class 1 rating from the Insurance Services Organization as well as receiving CAAS (Commission on Accreditation of Ambulance Services), being only the third fire department based ambulance service in the State to obtain this "gold standard" of care.

2026 Budget Totals

Department	2025 Budget	2026 Budget	Inc/(Dec)
175 Fire			
001-175-401 SALARIES	7,715,808	8,287,424	571,616
001-175-402 OVERTIME	350,000	600,000	250,000
001-175-460 RETIREMENT	515,000	666,557	151,557
001-175-470 FICA	594,237	679,888	85,651
001-175-490 SUTA	2,000	2,300	300
001-175-507 EQUIPMENT/SMALL	582,000	582,000	0
001-175-510 GAS/OIL	120,000	120,000	0
001-175-513 SUPPLIES/JANITORIAL	15,500	17,500	2,000
001-175-516 SUPPLIES/OPERATING	135,000	135,000	0
001-175-540 UNIFORMS	91,000	99,000	8,000
001-175-605 COMMUNICATIONS	68,000	160,000	92,000
001-175-608 DUES/MEMBERSHIP/SUBSCRIPT	5,000	6,000	1,000
001-175-612 PROFESSIONAL FEES	380,400	380,400	0
001-175-614 RENTALS	25,000	42,000	17,000
001-175-616 RPR/MAINT PLANT/BLDGS	170,000	170,000	0
001-175-618 RPR MAINT/EQUIPMENT	75,000	85,000	10,000
001-175-622 RPR/MAINT VEHICLES	268,333	280,000	11,667
001-175-630 TRAINING/TRAVEL	100,000	110,000	10,000
001-175-635 UTILITIES	80,000	105,000	25,000
175 Fire Subtotal	11,292,278	12,528,069	1,235,791



Orange Beach Public Works

Purpose: The City of Orange Beach Public Works Department is composed of the Street, Landscaping, Custodial and Refuse Divisions. The Public Works Department plays an integral role in emergency management and disaster recovery.

History: The Public Works Department moved from its long-time home on William Silvers Parkway to make way for the new Orange Beach Middle/High School and officially opened its new headquarters in March 2021 at 7394 Roscoe Road.

Hours: Monday through Friday, 6:30 a.m. to 3 p.m.

Phone: 251-923-5858

Website: <https://www.orangebeachal.gov/313/Public-Works>

Staff: 66 full-time employees

Director: Tim Tucker

Budget: \$9,039,248

Street: \$3,686,422

Landscaping: \$1,424,037

Refuse: \$3,928,789

Reason for 2026 budget increase: Operating line items for 2026 up \$37,810 from 2025. Supplies and operating increase \$12,375 based on YTD totals, uniform request up \$1,200 based on supplier info, added \$5,000 to rental account for unforeseen repairs or projects. Training/travel increase \$20,000 for employee CDL training and certification. Overall a 1% increase request. Landscape budget decrease \$94,761 as golf and sportsplex turf maintenance are completely off our budget.

Features:

- The **Street Division** maintains the streets, rights-of-ways, and drainage within the City of Orange Beach.
 - Employees:34
 - The **Landscaping Division** maintains city property grounds including the recreational parks, school facilities, and welcome areas.
 - Employees: 16
- The **Custodial Division** enhances the overall quality of life for employees, residents and visitors through clean, safe and sanitary facilities.
 - Employees: 7
- The **Refuse Division** keeps all of the rights-of-ways clear of trash and debris. Refuse also assists property owners in disposing of vegetative yard debris, household debris including appliances and furniture. Residential garbage and recycling is collected by a private contractor. Employees: 9

2026 Budget Totals

Department	2025 Budget	2026 Budget	Inc/(Dec)
200 Street			
001-200-401 SALARIES	2,042,649	2,189,520	146,871
001-200-402 OVERTIME	50,000	50,000	0
001-200-460 RETIREMENT	132,500	167,964	35,464
001-200-470 FICA	133,875	171,323	37,448
001-200-490 SUTA	700	700	0
001-200-507 EQUIPMENT/SMALL	33,000	33,000	0
001-200-510 GAS/OIL	120,000	120,000	0
001-200-513 SUPPLIES/JANITORIAL	33,000	33,000	0
001-200-516 SUPPLIES/OPERATING	123,750	136,125	12,375
001-200-540 UNIFORMS	11,990	13,190	1,200
001-200-605 COMMUNICATIONS	18,600	18,600	0
001-200-612 PROFESSIONAL FEES	60,000	60,000	0
001-200-614 RENTALS	15,000	20,000	5,000
001-200-616 RPR/MAINT PLANT/BLDGS	55,000	55,000	0
001-200-618 RPR/MAINT EQUIPMENT	136,000	136,000	0
001-200-620 RPR/MAINT GROUNDS	120,000	120,000	0
001-200-622 RPR/MAINT VEHICLES	66,000	66,000	0
001-200-630 TRAINING/TRAVEL	16,000	36,000	20,000
001-200-635 UTILITIES	260,000	260,000	0
200 Street Subtotal	3,428,064	3,686,422	258,358

2026 Budget Totals

Department	2025 Budget	2026 Budget	Inc/(Dec)
210 Landscaping			
001-210-401 SALARIES	749,711	771,516	21,805
001-210-402 OVERTIME	30,000	30,000	0
001-210-460 RETIREMENT	93,700	60,114	(33,586)
001-210-470 FICA	59,648	61,316	1,668
001-210-490 SUTA	500	500	0
001-210-507 EQUIPMENT/SMALL	50,000	50,000	0
001-210-510 GAS/OIL	76,000	76,000	0
001-210-516 SUPPLIES/OPERATING	100,000	100,000	0
001-210-540 UNIFORMS	5,610	6,171	561
001-210-605 COMMUNICATIONS	1,100	11,000	9,900
001-210-612 PROFESSIONAL FEES	50,000	25,000	(25,000)
001-210-614 RENTALS	3,000	3,000	0
001-210-616 RPR/MAINT PLANT/BLDG	45,000	25,000	(20,000)
001-210-618 RPR/MAINT EQUIPMENT	65,000	65,000	0
001-210-620 RPR/MAINT GROUNDS	135,000	110,000	(25,000)
001-210-622 RPR/MAINT VEHICLES	22,000	22,000	0
001-210-630 TRAINING/TRAVEL	4,000	4,000	0
001-210-635 UTILITIES	3,420	3,420	0
210 Landscaping Subtotal	1,493,689	1,424,037	(69,652)

2026 Budget Totals

Department	2025 Budget	2026 Budget	Inc/(Dec)
404 Refuse			
404-677-401 SALARIES	431,177	436,395	5,218
404-677-402 OVERTIME	10,000	10,000	0
404-677-460 RETIREMENT	27,595	33,480	5,885
404-677-470 FICA	33,750	34,149	399
404-677-490 SUTA	175	250	75
404-677-507 EQUIPMENT/SMALL	15,000	15,000	0
404-677-510 GAS/OIL	92,000	92,000	0
404-677-516 SUPPLIES/OPERATING	22,000	22,000	0
404-677-540 UNIFORMS	3,850	4,235	385
404-677-605 COMMUNICATIONS	6,000	6,000	0
404-677-612 PROFESSIONAL FEES	2,849,600	2,992,080	142,480
404-677-614 RENTALS	6,000	0	(6,000)
404-677-618 RPR/MAINT EQUIPMENT	107,000	120,000	13,000
404-677-622 RPR/MAINT VEHICLES	77,000	77,000	0
404-677-630 TRAINING/TRAVEL	3,000	3,000	0
404-677-635 UTILITIES	1,200	1,200	0
404-677-730 CAPITAL EQUIPMENT	235,000	82,000	(153,000)
404 Refuse Subtotal	3,920,347	3,928,789	8,442



Orange Beach Parks and Recreation

Purpose:

Parks and Recreation has a mission to provide fun, safe, and affordable recreational opportunities through exceptional park and recreational facilities that enhance the quality of life and promote healthy lifestyles for all participants and Orange Beach citizens. The department's motto is "Where Play Meets Paradise."

The facilities that make up Parks and Recreation include the Senior Center, Adult Fitness Center, Aquatics Center, Tennis Center, Golf Center, Sportsplex, History Museum, Waterfront Park, and Kids Park Playground. The department also oversees a variety of large-scale City events and community programs throughout the year.

In 2026, Parks and Recreation will expand to include the Event Center, Community Center, Arts Center, and the Expect Excellence divisions, bringing these programs and facilities under one departmental umbrella to enhance coordination, efficiency, and service to the community.

Hours: Vary by facility.
Phone: 251-981-2228
Website: <https://www.orangebeachal.gov/199/Parks-Recreation>
Staff: 38 full-time employees, 23 part-time employees, 19 seasonal employees
Director: Nicole Ard
Budget: \$6,397,429

Revenue: \$1,459,429.94 YTD through 10/30/25
Adult Fitness Center: \$952,085
Aquatics Center: \$705,807
Golf Center: \$898,332
Senior Center: \$342,873
Sportsplex: \$2,345,290
Tennis/Pickleball Center: \$296,697
Programs, Events, Museum: \$856,345

Reason for 2026 budget increase:

The main reason for the increase from 2025 to 2026 is tied to several upcoming changes in how we're structuring and funding our department.

- We're moving several employees from the Expect Excellence program into the Sportsplex payroll so their funding better matches where they actually work.

- Some of the larger City event and festival expenses will be shifted out of the main Administration budget and into specific event management lines.
- We're also adding an administrative position to help manage the significant departmental changes coming in 2026, including the addition of the Events Center, Community Center, Coastal Arts Center, and Expect Excellence divisions under the Parks and Recreation department umbrella.

While there's an initial cost increase, the new structure will ultimately save money and make our operations more efficient as staffing transitions occur over time.

Features:

- The **Adult Fitness Center** is a 17,400-square-foot, state-of-the-art facility dedicated to promoting health, strength, and community wellness. The open-concept layout features a variety of top-tier cardio machines, free weights, and strength-training equipment. A dedicated group fitness studio hosts a range of dynamic classes designed for all fitness levels, encouraging active lifestyles and social engagement among members. Members enjoy 24-hour access for flexibility, along with the option to work with certified personal trainers who provide individualized guidance and motivation. In addition to operating the Fitness Center, this division oversees the custodial staff responsible for maintaining the entire Recreation Complex, ensuring a clean, safe, and welcoming environment for all visitors.
 - Employees: 7 FT, 6 PT
 - Revenues: 2024: \$454,224.62 2025 YTD: \$438,341.07
- The **Aquatics Center** serves thousands of members each year and provides outdoor aquatic opportunities for all ages and abilities. The facility features a heated pool designed for lap swimming, aquatic fitness classes, and swim instruction, along with leisure areas for family enjoyment. Programs are designed to promote fitness, safety, and confidence in the water. The Aquatics Center also partners with OBMHS to host school swim meets as well as hosts OBST recreation league swim meets, lifeguard certification courses, and community water safety programs. Its dedicated staff ensures a safe, inclusive, and enjoyable environment for both recreational and competitive swimmers.
 - Employees: 3 FT, 9 PT, 10 Temp
 - Revenues: 2024: \$37,293.00 2025 YTD: \$27,092.95
 - *Membership revenues are included under the Adult Fitness Center*
- The **Golf Center** offers a beautifully maintained 9-hole, par-3 course that welcomes players of all skill levels. The facility features a fully lighted driving range, expansive practice putting and chipping greens, a sand bunker for short-game practice, a large artificial turf green, and a new simulation teaching room for year-round training. A well-stocked Pro Shop provides equipment, apparel, and professional instruction. Open seven days a week, the Golf Center continues to grow in the number of rounds played

each year and has become a staple of the community for local golfers. It serves both residents and visitors as a welcoming and accessible venue for recreation, practice, and fellowship.

- Employees: 8 FT, 6 PT
 - Revenues: 2024: \$620,994.87 2025 YTD: \$669,241.02
- The building that houses the **History Museum** was originally constructed in 1910 as a schoolhouse. It has served as a museum since 1995 and was relocated to its current site in 1999. The museum preserves and celebrates the city’s rich coastal heritage, featuring rotating exhibits, educational displays, and community programs that highlight the people, culture, and history of Orange Beach.
 - Employees: 1 FT
 - Revenues: N/A
- The **Senior Center** provides a welcoming space for active adults to connect, learn, and enjoy recreational opportunities. The facility includes an arts and crafts room, a game room, a multi-purpose room, and a screened porch overlooking Wolf Bay. It offers a full calendar of programs, classes, and social activities that promote engagement, creativity, and lifelong wellness. In addition, the Senior Center serves as a rental venue for a variety of local civic and private groups, hosting meetings, weddings, and small events that bring the community together.
 - Employees: 2 FT
 - Revenues: 2024: \$16,773 2025 YTD: \$15,400
- The **Sportsplex**, opened in the spring of 2001, is one of the region’s premier sports destinations. The complex includes softball, baseball, and football/soccer fields, along with a three-court sand volleyball area and three concession stands. Its 1,500-seat stadium features a press box and locker rooms, providing a professional experience for athletes and spectators alike. The Sportsplex serves as the home of Orange Beach Middle and High School soccer, baseball, softball, cross country, and other athletic programs. It also hosts numerous large-scale national tournaments, travel ball competitions, and community and trail events, contributing significantly to local sports tourism and economic activity.
 - Employees: 13 FT, 2 PT, 9 Temp
 - Revenues: 2024: \$224,123.15 2025 YTD: \$239,755.83
- The **Tennis Center** features eight lighted hard courts open seven days a week. The facility serves as the home of OBMHS tennis and regularly hosts USTA and local league tournaments. Currently undergoing renovations, the center will soon include a small meeting space and Pro Shop serving both tennis and pickleball players. **Pickleball Center** facilities are scheduled for completion in early 2026 and will feature 14 courts, a pavilion, and a restroom area, expanding recreational options for residents and visitors alike.
 - Employees: 1 FT
 - Revenues: 2024: \$16,776.25 2025 YTD: \$1,222.50
 - *Changed tennis pro format in 2025, affecting revenues*
- Orange Beach Parks and Recreation coordinates and supports a diverse lineup of community **Programs and Events** that bring residents and visitors together throughout

the year. Major annual events include Freedom Fest, Seafood Fest, and the Christmas Tree Lighting, each drawing large crowds and showcasing the community's coastal charm and hospitality. In addition to these cornerstone celebrations, the department organizes and supports a variety of smaller special events such as the Summer Soirée, Fido Fest, Pop-Up Park experiences, the Coastal Table culinary series, the Summer Sendoff, the Orange Beach Farmers Market, and History Tours that highlight the area's rich cultural heritage. Together, these programs and events represent the City's ongoing commitment to community engagement and quality of life. They encompass new wellness and fitness initiatives, recreational activities, and educational experiences that promote active, healthy living and lifelong learning for residents of all ages.

Employees: 2 FT - Works with all City employees and local organizations

Revenues: \$68,376.57 YTD 2025 **This includes the two grants from Alabama's Beaches for festivals and events*

2026 Budget Totals

Department	2025 Budget	2026 Budget	Inc/(Dec)
300 Parks & Recreation			
001-300-401 SALARIES	315,635	457,437	141,802
001-300-402 OVERTIME	4,000	4,000	0
001-300-460 RETIREMENT	50,000	34,608	(15,392)
001-300-470 FICA	24,452	35,300	10,848
001-300-490 SUTA	500	500	0
001-300-507 EQUIPMENT/SMALL	5,000	60,000	55,000
001-300-510 GAS/OIL	0	500	500
001-300-513 SUPPLIES/JANITORIAL	300	1,500	1,200
001-300-516 SUPPLIES/OPERATING	50,000	65,000	15,000
001-300-540 UNIFORMS	1,000	1,000	0
001-300-605 COMMUNICATIONS	4,000	6,500	2,500
001-300-608 DUES/MEMBERSHIP/SUBSCRIPT	5,000	5,000	0
001-300-612 PROFESSIONAL FEES	5,000	10,000	5,000
001-300-614 RENTALS	0	0	0
001-300-616 RPR/MAINT PLANT/BLDGS	5,000	8,000	3,000
001-300-618 RPR/MAINT EQUIPMENT	7,000	10,000	3,000
001-300-620 RPR/MAINT GROUNDS	1,000	8,000	7,000
001-300-622 RPR/MAINT VEHICLES	500	500	0
001-300-630 TRAINING/TRAVEL	6,500	9,000	2,500
001-300-635 UTILITIES	45,000	45,000	0
001-300-650 EXHIBITIONS & PROMOTIONS	3,500	93,500	90,000
001-300-660 COST OF GOODS SOLD RETAIL	1,000	1,000	0
300 Parks & Recreation Subtotal	534,387	856,345	321,958

2026 Budget Totals

Department	2025 Budget	2026 Budget	Inc/(Dec)
301 Parks & Recreation - Sportsplex			
001-301-401 SALARIES	692,746	835,000	142,254
001-301-402 OVERTIME	25,000	25,000	0
001-301-460 RETIREMENT	45,000	64,500	19,500
001-301-470 FICA	54,908	65,790	10,882
001-301-490 SUTA	500	500	0
001-301-507 EQUIPMENT/SMALL	85,000	100,500	15,500
001-301-510 GAS/OIL	5,000	10,000	5,000
001-301-513 SUPPLIES/JANITORIAL	3,000	5,000	2,000
001-301-516 SUPPLIES/OPERATING	420,000	175,000	(245,000)
001-301-540 UNIFORMS	5,000	5,000	0
001-301-605 COMMUNICATIONS	6,000	9,000	3,000
001-301-608 DUES/MEMBERSHIP/SUBSCRIPT	5,000	5,000	0
001-301-612 PROFESSIONAL FEES	215,000	201,000	(14,000)
001-301-614 RENTALS	15,000	15,000	0
001-301-616 RPR/MAINT PLANT/BLDGS	70,000	205,000	135,000
001-301-618 RPR/MAINT EQUIPMENT	50,000	50,000	0
001-301-620 RPR/MAINT GROUNDS	70,000	274,000	204,000
001-301-622 RPR/MAINT VEHICLES	5,500	5,000	(500)
001-301-630 TRAINING/TRAVEL	5,000	5,000	0
001-301-635 UTILITIES	160,000	130,000	(30,000)
001-301-660 COST OF GOODS SOLD	0	160,000	160,000
301 Parks & Recreation Subtotal	1,937,654	2,345,290	407,636

2026 Budget Totals

Department	2025 Budget	2026 Budget	Inc/(Dec)
302 Parks & Recreation - Pool			
001-302-401 SALARIES	311,390	361,400	50,010
001-302-402 OVERTIME	2,000	3,000	1,000
001-302-460 RETIREMENT	10,000	27,330	17,330
001-302-470 FICA	23,974	27,877	3,902
001-302-490 SUTA	300	300	0
001-302-507 EQUIPMENT/SMALL	26,000	30,000	4,000
001-302-513 SUPPLIES/JANITORIAL	3,000	3,000	0
001-302-516 SUPPLIES/OPERATING	28,000	38,000	10,000
001-302-540 UNIFORMS	3,200	3,500	300
001-302-605 COMMUNICATIONS	2,500	5,000	2,500
001-302-612 PROFESSIONAL FEES	68,000	5,500	(62,500)
001-302-614 RENTALS	0	1,000	1,000
001-302-616 RPR/MAINT PLANT/BLDGS	91,000	91,000	0
001-302-618 RPR/MAINT EQUIPMENT	7,000	7,000	0
001-302-620 RPR/MAINT GROUNDS	900	900	0
001-302-630 TRAINING/TRAVEL	7,000	8,000	1,000
001-302-635 UTILITIES	80,000	92,000	12,000
001-302-650 EXHIBITIONS & PROMOTIONS	1,000	1,000	0
302 Parks & Recreation Subtotal	665,264	705,807	40,542

2026 Budget Totals

Department	2025 Budget	2026 Budget	Inc/(Dec)
303 Parks & Recreation - Golf			
001-303-401 SALARIES	391,073	460,327	69,254
001-303-402 OVERTIME	10,000	10,000	0
001-303-460 RETIREMENT	20,000	34,525	14,525
001-303-470 FICA	30,682	35,980	5,298
001-303-490 SUTA	100	200	100
001-303-507 EQUIPMENT/SMALL	25,000	20,000	(5,000)
001-303-510 GAS/OIL	5,000	5,000	0
001-303-513 SUPPLIES/JANITORIAL	1,500	1,500	0
001-303-516 SUPPLIES/OPERATING	25,000	25,000	0
001-303-540 UNIFORMS	2,500	3,000	500
001-303-605 COMMUNICATIONS	7,000	7,000	0
001-303-608 DUES/MEMBERSHIP/SUBSCRIPT	200	1,300	1,100
001-303-612 PROFESSIONAL FEES	57,000	22,000	(35,000)
001-303-614 RENTALS	1,200	3,000	1,800
001-303-616 RPR/MAINT PLANT/BLDGS	25,000	53,000	28,000
001-303-618 RPR/MAINT EQUIPMENT	35,000	35,000	0
001-303-620 RPR/MAINT GROUNDS	95,000	95,000	0
001-303-622 RPR/MAINT VEHICLES	2,000	2,000	0
001-303-630 TRAINING/TRAVEL	3,000	3,500	500
001-303-635 UTILITIES	16,000	16,000	0
001-303-650 EXHIBITIONS & PROMOTIONS	10,000	10,000	0
001-303-660 COST OF GOODS SOLD RETAIL	35,000	55,000	20,000
303 Parks & Recreation Subtotal	797,255	898,332	101,076

2026 Budget Totals

Department	2025 Budget	2026 Budget	Inc/(Dec)
304 Parks & Recreation - Sr. Center			
001-304-401 SALARIES	113,402	132,670	19,268
001-304-402 OVERTIME	2,000	2,000	0
001-304-460 RETIREMENT	10,000	10,100	100
001-304-470 FICA	8,828	10,302	1,474
001-304-490 SUTA	100	200	100
001-304-507 EQUIPMENT/SMALL	15,000	15,000	0
001-304-510 GAS/OIL	1,000	1,000	0
001-304-513 SUPPLIES/JANITORIAL	1,500	1,500	0
001-304-516 SUPPLIES/OPERATING	12,000	14,000	2,000
001-304-540 UNIFORMS	500	500	0
001-304-605 COMMUNICATIONS	3,000	5,500	2,500
001-304-608 DUES/MEMBERSHIP/SUBSCRIPT	100	100	0
001-304-612 PROFESSIONAL FEES	12,500	12,500	0
001-304-614 RENTALS	0	0	0
001-304-616 RPR/MAINT PLANT/BLDGS	50,000	95,000	45,000
001-304-618 RPR/MAINT EQUIPMENT	1,500	1,500	0
001-304-620 RPR/MAINT GROUNDS	95,000	27,000	(68,000)
001-304-622 RPR/MAINT VEHICLES	1,000	1,000	0
001-304-630 TRAINING/TRAVEL	3,000	3,000	0
001-304-635 UTILITIES	8,000	10,000	2,000
001-304-650 EXHIBITIONS & PROMOTIONS	0	0	0
304 Parks & Recreation Subtotal	338,430	342,873	4,442

2026 Budget Totals

Department	2025 Budget	2026 Budget	Inc/(Dec)
305 Tennis/Pickleball			
001-305-401 SALARIES		66,800	66,800
001-305-402 OVERTIME		1,000	1,000
001-305-460 RETIREMENT		5,010	5,010
001-305-470 FICA		5,187	5,187
001-305-490 SUTA		200	200
001-305-507 EQUIPMENT/SMALL		75,000	75,000
001-305-513 SUPPLIES/JANITORIAL		0	0
001-305-516 SUPPLIES/OPERATING		8,000	8,000
001-305-540 UNIFORMS		500	500
001-305-605 COMMUNICATIONS		5,000	5,000
001-305-612 PROFESSIONAL FEES		35,000	35,000
001-305-614 RENTALS		0	0
001-305-616 RPR/MAINT PLANT/BLDGS		15,000	15,000
001-305-618 RPR/MAINT EQUIPMENT		20,000	20,000
001-305-620 RPR/MAINT PLANT/GROUNDS		2,000	2,000
001-305-630 TRAINING/TRAVEL		3,000	3,000
001-305-635 UTILITIES		43,000	43,000
001-305-660 COST OF GOODS RETAIL		12,000	12,000
305 Tennis/Pickeball Subtotal	0	296,697	296,697

2026 Budget Totals

Department	2025 Budget	2026 Budget	Inc/(Dec)
325 Fitness Center			
001-325-401 SALARIES	439,785	354,402	(85,383)
001-325-402 OVERTIME	2,500	2,500	0
001-325-460 RETIREMENT	40,000	26,580	(13,420)
001-325-470 FICA	33,835	27,303	(6,532)
001-325-490 SUTA	200	300	100
001-325-507 EQUIPMENT/SMALL	180,000	125,000	(55,000)
001-325-513 SUPPLIES/JANITORIAL	35,000	38,000	3,000
001-325-516 SUPPLIES/OPERATING	30,000	30,000	0
001-325-540 UNIFORMS	2,000	2,000	0
001-325-605 COMMUNICATIONS	10,000	10,000	0
001-325-612 PROFESSIONAL FEES	90,000	83,000	(7,000)
001-325-614 RENTALS	0	0	0
001-325-616 RPR/MAINT PLANT/BLDGS	155,000	130,000	(25,000)
001-325-618 RPR/MAINT EQUIPMENT	20,000	20,000	0
001-325-620 RPR/MAINT PLANT/GROUNDS	2,000	2,000	0
001-325-630 TRAINING/TRAVEL	3,000	3,000	0
001-325-635 UTILITIES	80,000	95,000	15,000
001-325-660 COST OF GOODS RETAIL	0	3,000	3,000
325 Fitness Center Subtotal	1,123,320	952,085	(171,235)



Orange Beach Expect Excellence

Purpose: Expect Excellence is a unique quality-of-life enhancing department of the City of Orange Beach that offers all Orange Beach residents opportunities in academics, continued education, arts and enrichment, and athletics. The Expect Excellence department includes a free after-school program for kindergarten-sixth grade students, a pre-K after school program, a Summer Camp program for rising first-seventh grade students, Performing Arts/Theatre for all ages, a teaching Music Studio for all ages, and a variety of athletic training camps and programs.

History: In 2018, Mayor Tony Kennon and the City Council began “Expect Excellence,” a program geared at after-school training in academics, arts and athletics. The program absorbed the successful Camp Sunshine and continues to grow.

Hours: After-School - 10 a.m. to 6 p.m., Summer Camp - 7 a.m. to 6 p.m.
Phone: 251-981-7836
Website: <https://www.orangebeachal.gov/418/Expect-Excellence>
Staff: 17 full-time employees, 110 part-time employees, 30 seasonal employees
Directors: Sara Carroll (Programs) and Polly Pittman (Administration)
Budget: Revenue: EE = \$151,498.00 (minus 3.66% = \$145,953.17), and PAC = \$62,597.25

Jan.-Oct. '25 REVENUE (350 & 375) = \$208,550

Expense: EE = \$2,901,794 and PAC = \$842,139

TOTAL EXPENSE (350 & 375) = \$3,743,933

Reason for 2026 budget increase:

\$82,712 increase in budget request for 2026 can be broken down into two categories:

Salaries:

Our budget will now account for one full time position previously absorbed by the Admin department, as well as adjusting our part time Academic Coordinator to their previous salary.

New Positions:

Arts and Enrichment Coordinator (Full Time): this role was previously fulfilled by the Creative Director position, which fell in the Admin budget.

Administrative position (Full Time): with a rise in the number of registrants and the addition of multiple programs, administrative tasks have increased exponentially. We have

requested an additional staff member in 2026 to assist with these.

- **Repair/Maint.-Buildings:**
 - We will need to replace an AC unit at the Recreation Center, as well as significant HVAC repairs at the Music Building.

Features:

- Expect Excellence After-School Care and Summer Camp are enhanced programs of Academics, Arts, and Athletics. The goal of Expect Excellence is to teach CHARACTER, INTEGRITY, WORK ETHIC, RESPECT, & DISCIPLINE.
 - Employees: 144
- Expect Excellence Theatre is based at the Orange Beach Performing Arts Center, producing performances throughout the year.
 - Employees: 8
- Expect Excellence Music Division works closely with the Expect Excellence after-school and summer camp programs, and also produces two musical programs each year at the Performing Arts Center.
 - Employees: 5

2026 Budget Totals

Department	2025 Budget	2026 Budget	Inc/(Dec)
350 Expect Excellence			
001-350-401 SALARIES	2,033,869	2,116,581	82,712
001-350-402 OVERTIME	40,000	30,000	(10,000)
001-350-460 RETIREMENT	57,000	65,000	8,000
001-350-470 FICA	158,651	164,213	5,562
001-350-490 SUTA	3,000	4,000	1,000
001-350-507 EQUIPMENT/SMALL	90,500	65,000	(25,500)
001-350-510 GAS/OIL	4,000	3,000	(1,000)
001-350-516 SUPPLIES/OPERATING	82,000	76,500	(5,500)
001-350-540 UNIFORMS	10,000	10,000	0
001-350-605 COMMUNICATIONS	9,500	9,500	0
001-350-608 LEASES/SUBSCRIPTION	2,000	1,000	(1,000)
001-350-612 PROFESSIONAL FEES	30,000	46,000	16,000
001-350-616 RPR/MAINT BLDG	212,000	200,000	(12,000)
001-350-618 RPR/MAINT EQUIPMENT	6,000	6,000	0
001-350-622 RPR/MAINT VEHICLES	10,000	12,000	2,000
001-350-630 TRAINING/TRAVEL	6,000	8,000	2,000
001-350-635 UTILITIES	85,000	85,000	0
350 Expect Excellence Subtotal	2,839,520	2,901,794	62,274

2026 Budget Totals

Department	2025 Budget	2026 Budget	Inc/(Dec)
375 Performing Arts Center			
001-375-401 SALARIES	393,009	273,992	(119,017)
001-375-402 OVERTIME	25,000	25,000	0
001-375-460 RETIREMENT	27,500	22,424	(5,076)
001-375-470 FICA	31,978	22,873	(9,105)
001-375-490 SUTA	200	400	200
001-375-507 EQUIPMENT/SMALL	120,000	147,050	27,050
001-375-510 GAS/OIL	6,000	6,000	0
001-375-513 SUPPLIES/JANITORIAL	1,000	2,000	1,000
001-375-516 SUPPLIES/OPERATING	49,100	49,100	0
001-375-540 UNIFORMS	1,200	2,000	800
001-375-605 COMMUNICATIONS	1,000	1,000	0
001-375-608 DUES/MEMBERSHIPS/SUBSCRIPTIONS	4,200	3,000	(1,200)
001-375-612 PROFESSIONAL FEES	61,100	88,300	27,200
001-375-614 RENTALS	4,000	2,000	(2,000)
001-375-616 RPR/MAINT PLANT/BLDGS	10,000	5,000	(5,000)
001-375-618 RPR/MAINT EQUIPMENT	35,000	35,000	0
001-375-630 TRAINING/TRAVEL	5,000	7,000	2,000
001-375-636 PRODUCTION COST	150,000	150,000	0
375 Performing Arts Center Subtotal	925,287	842,139	(83,147)



Orange Beach Coastal Resources

Purpose: The Coastal Resources Department is committed to preserving and maintaining the local beaches, shorelines, trails and wildlife, and other outdoor recreational amenities, all of which greatly enhance our quality of life and sustain the local tourism-based economy. The Department also plays roles in post-disaster recovery and FEMA coordination, Inter-agency coordination, and is represented on several State and Regional Boards and Commissions. The department has nine divisions: Administration, Beach, Trails, Wildlife, Wind & Water Learning Center, Special Projects, Regulatory, Shooting Complex and Waterways & Shoreline cleanup.

History: The Department began as a division of Community Development, in 2004. At that time, only 3 employees made up the division, but it grew slowly but steadily throughout the years as more responsibilities were added to the Division, such as the beach renourishment program, recreational project development, EMA roles, grant management, et al. In 2016, the City adopted the "Clean Beach Initiatives," which included the Leave Only Footprints program, Beach Ambassadors, and beach maintenance. Once this program was established, Coastal Resources became a stand-alone department, and grew rapidly in a short period of time. Most recently, the Department has taken on the responsibility of managing the Orange Beach Trap & Skeet facility and Rifle Range (under construction).

Hours: Monday through Friday, 8 a.m. to 5 p.m. (Beach Programs run 7 days a week, 365 days a year, 6 a.m. to 12:00 a.m.)

Phone: 251-981-1063

Website: <https://www.orangebeachal.gov/228/Coastal-Resources>

Staff: 25 full-time employees, 14 part-time employees, 20-30 seasonal

Director: Phillip West, AICP

Budget: \$3,307,865

Reason for 2026 budget increase: \$5,000 increase in overtime to cover additional staffing needs on holidays/festivals/field trips. \$28,000 in operating to cover additional truck load of clays for skeet range operation. \$5,000 increase in utilities for additional facilities coming on line.

Features:

- The **Administration Division** provides assistance to the development community to ensure growth along the beach is environmentally permitted by coordinating with state and federal agencies, and guides the direction of the Department to ensure the city's goals are being accomplished. Staff also handles the management of over \$20 million in grant funds and handles Emergency Management Coordination and post-disaster debris removal.

- Employees: 4 full-time
- The **Wind & Water Learning Center** is committed to enhancing life for locals and guests by providing coastal access, waterfront facilities, equipment, sailing and kayaking opportunities, and environmental education. WWLC is the official sailing facility for Orange Beach High School's Sailing Club, a designated Alabama Coastal Cleanup site, an active member of U.S. Sailing, and an affiliate of the American Canoe Association, following many of their accredited classes and guidelines.
 - Employees: 1 full-time; 1 part-time; up to 6 seasonal employees
- The **Beach Division** is committed to ensuring an optimal quality of life for its beach community and environment through education, advocacy, restoration, conservation, and protection. As part of the Share the Beach initiative, the division works to foster a suitable habitat for our local protected nesting turtle species. Through the Leave Only Footprints campaign staff works daily to maintain a pristine coastline for years to come, as well as providing Beach Ambassadors to make personal contact with beach visitors (up to 75,000 public interactions per year). This division is also responsible for the grooming of the beach and trash removal from the 8.5 miles of beach and four state-owned public beach accesses, as well as Pass Park.
 - Employees: 9 full-time; 2 part-time; 15-20 seasonal employees
- **Waterways & Shoreline Cleanup** - The City of Orange Beach began a pilot program in 2014 to address marine debris and waterborne trash titled the "Waterways and Shoreline Enhancement Program" (WSEP). The program was designed to mitigate marine debris and waterborne trash on a daily basis among the 46+ miles of shoreline, as well keeping "the islands" clean and suitable for public use and nesting shorebirds. The Division also assists frequently with field trips and other educational programs. This program has been expanded, staffed, equipped and funded through grant funding from GOMESA, NOAA and NFWF*.
 - Employees: 2 full-time/up to 4 part-time
- The **Trail Division** maintains and educates the public to ensure the safety of the Hugh S. Branyon Backcountry Trail system. This multipurpose trail is shared by hikers, cyclists, photographers, and nature lovers all year round. The division ensures that guests enjoy all six diverse ecosystems of the top-rated recreational trail in the country. This division also maintains the community garden, city dog park, and canoe trail sites around the city, and maintains the new Orange Beach Shooting Complex.
 - Employees: 2 full-time/3 part-time
- The mission of the **Special Projects Division** is to take an idea, a vision or project and design and construct it quickly and efficiently. From building benches and swings for the Backcountry Trail or designing and constructing enclosures and rehab facilities for the Wildlife Center to building the Police pistol range and the City Trap and Skeet Range. From designing and creating signs throughout the city to performing maintenance on existing facilities, Special Projects make ideas come to life.
 - Employees: 2 full-time/2 part-time
- The **Orange Beach Wildlife Center's** mission is the protection and preservation of wildlife through management, rescue, rehabilitation and education. The Center operates under state and federal permits and licenses to provide rehabilitation services for injured

and orphaned wildlife. In addition, it hosts a resident internship program and offers educational programming throughout the community.

- Employees: 2 full-time; 2 seasonal; up to 7 interns
- The **Alabama Coastal Bird Stewardship Program** started in 2018 and is thriving due to the partnership with the State of Alabama-Department of Conservation and Natural Resources and the National Audubon Society. These organizations continue to provide funding for a conservation position to promote public outreach, education, and communal support as well as ordinance enforcement.
 - Employees: 1 full-time
- The **Regulatory Program Division** oversees and manages the various regulatory and permitting programs for which the Department is responsible, including beachfront construction permitting (delegated to the city by the ADEM**), beach mouse permitting on Perdido Key, marine accessory structures, and serves as the Department liaison to the Orange Beach Planning Commission.
 - Employees: 1 full-time
- The **Orange Beach Shooting Complex** is the newest addition to the Coastal Resource's responsibilities, with the Trap & Skeet facility opening in September, 2025, with 5 trap and 5 skeet fields (superimposed) open to the public and serve as the home field for the Orange Beach High School and Middle schools Shooting Team. The staff—along with support from the Department's other Divisions, is currently working on a rifle range (up to 300-yards) that will be open to the public. Both the shotgun and rifle facilities will be "fee-based", providing additional revenue to the city.
 - Employees: 2 part-time, currently

*NFWF—National Fish & Wildlife Foundation; NOAA—National Atmospheric & Oceanic Administration; GOMESA—Gulf of Mexico Energy Security Act (offshore oil lease revenues)

**ADEM—Alabama Department of Environmental Management

2026 Budget Totals

Department	2025 Budget	2026 Budget	Inc/(Dec)
410 Coastal Resources			
001-410-401 SALARIES	1,837,370	1,847,370	10,000
001-410-402 OVERTIME	10,000	15,000	5,000
001-410-460 RETIREMENT	97,000	100,000	3,000
001-410-470 FICA	141,324	141,706	383
001-410-490 SUTA	1,000	1,000	0
001-410-507 EQUIPMENT/SMALL	196,000	196,000	0
001-410-510 GAS/OIL	86,500	86,500	0
001-410-513 SUPPLIES/JANITORIAL	11,000	11,000	0
001-410-516 SUPPLIES/OPERATING	121,000	154,000	33,000
001-410-540 UNIFORMS	9,650	9,650	0
001-410-605 COMMUNICATIONS	35,880	35,880	0
001-410-608 DUES/MEMBERSHIP/SUBSCRIPT	3,475	3,475	0
001-410-612 PROFESSIONAL FEES	75,000	75,000	0
001-410-614 RENTALS	31,000	31,000	0
001-410-616 RPR/MAINT PLANT/BLDGS	36,000	36,000	0
001-410-618 RPR/MAINT EQUIPMENT	46,000	46,000	0
001-410-620 RPR/MAINT GROUNDS	43,500	43,500	0
001-410-622 RPR/MAINT VEHICLES	39,000	39,000	0
001-410-630 TRAINING/TRAVEL	18,000	18,000	0
001-410-635 UTILITIES	72,000	77,000	5,000
001-410-640 EMA	100,000	100,000	0
001-410-650 AUDUBON	25,000	25,000	0
001-410-652 STATE PARK EXPENSES	25,000	25,000	0
410 Coastal Resources Subtotal	3,060,699	3,117,081	56,383



Orange Beach Sewer Department

Purpose: The City of Orange Beach Sewer Department is responsible for the collection and treatment of wastewater in Orange Beach and portions of the surrounding area. The Department is organized into two general areas of responsibility: Field Division and Plant Division.

History: The Wastewater Treatment Plant went into operation in 2011 with a permitted discharge capacity of 10 million gallons per day (MGD). The plant produces a crystal clear discharge into the Intracoastal Canal. Current flows range from around 2 MGD in the winter to over 4 MGD in the summer. Every month in 2025 through August has seen record sewer flow numbers with July being the highest with a 4.85 MGD average (up 4% from 2024). The plant is staffed 24/7 by certified operators.

Hours: Monday through Friday, 7:30 a.m. to 4 p.m.
Phone: 251-974-5617
Website: <https://www.orangebeachal.gov/322/Sewer>
Staff: 25 full-time employees, 4 part-time employees
Director: Robby Stalcup
Budget:

Revenue: \$7,955,000
Expense: \$9,333,699

Reason for 2026 budget increase:

We are requesting a budget increase to fund essential planning and infrastructure improvements to the sewer system.

The additional funds will cover the costs of surveying, design, and permitting for a 5 MGD expansion of the wastewater treatment plant, which is necessary to accommodate future growth and to ensure continued compliance with environmental regulations.

The budget increase will also support several critical system upgrades:

- Upgrading the County Road 4 lift station with a larger wet well to improve capacity and reliability.
- Rebuilding the Wolf Bay lift station, which has never been updated and is in need of a completed rehabilitation to maintain service reliability.
- Installing a new line extension down Russian Road to the shooting range.
- Replacing all aeration diffusers at the wastewater treatment plant to enhance operational efficiency and treatment performance.

Additionally, we plan to purchase another Godwin pump to provide backup support during lift station failures and maintenance events, minimalizing downtime and potential overflows.

These projects are necessary to to maintain operational efficiency, meet service growing demands, and ensure the long-term sustainability of our wastewater infrastructure.

Features:

- The **Field Division** deals primarily with customer service and the operation and maintenance of the collection system.
 - Employees: 11
- The Field Division is responsible for installing new taps and the general maintenance and necessary repairs to approximately 130 miles of sewer mains and 25 lift stations. This includes about 33 miles on the north side of the Intracoastal Canal and 14 miles on Ono Island.
- The **Plant Division** is responsible for the operation and maintenance of the Wastewater Treatment Plant. Each division has specific ADEM certification and staffing requirements.
 - Employees: 14
- We have **two** Superintendents: One for the Plant Division and one for the Field Division. The Field Superintendent is responsible for the efficient, reliable, and safe operation of the wastewater collection system. This includes supervising personnel, overseeing the maintenance and repair activities, and ensuring system reliability and compliance with safety standards. The Plant Superintendent is responsible for the overall planning, operations, maintenance, and supervision of the wastewater treatment plant. This role ensures the facility operates efficiently, effectively, and in full compliance with regulatory requirements.
- The Sewer Department has **two** administrative employees, they are responsible for budgeting, management, and strategic planning, while also overseeing the field and plant divisions to ensure efficient operations and long-term organizational success.

2026 Budget Totals

Department	2025 Budget	2026 Budget	Inc/(Dec)
403 Sewer			
403-676-401 SALARIES	1,691,348	1,901,961	210,613
403-676-402 OVERTIME	90,000	60,000	(30,000)
403-676-460 RETIREMENT	121,429	133,137	11,708
403-676-470 FICA	136,273	145,500	9,227
403-676-490 SUTA	450	600	150
403-676-507 EQUIPMENT/SMALL	25,000	25,000	0
403-676-510 GAS/OIL	65,000	65,000	0
403-676-516 SUPPLIES/OPERATING	480,000	480,000	0
403-676-540 UNIFORMS	19,000	19,000	0
403-676-605 COMMUNICATIONS	36,000	36,000	0
403-676-612 PROFESSIONAL FEES	132,500	132,500	0
403-676-614 RENTALS	5,000	10,000	5,000
403-676-616 RPR/MAINT PLANT/BLDGS	785,000	785,000	0
403-676-618 RPR/MAINT SMALL EQUIP	10,000	11,000	1,000
403-676-622 RPR/MAINT VEHICLES	80,000	88,000	8,000
403-676-630 TRAINING/TRAVEL	10,000	15,000	5,000
403-676-635 UTILITIES	1,100,000	1,100,000	0
403-676-655 BAD DEBTS	0	0	0
403-676-710 PLANT UPGRADES	0	0	0
403-676-720 GROUNDS UPGRADE	360,000	2,026,000	1,666,000
403-676-730 CAPITAL EQUIPMENT	320,000	137,000	(183,000)
403 Sewer Subtotal	5,467,000	7,170,699	1,703,698



Orange Beach Event Center

Purpose: The Event Center is home to nearly 100 events annually, from corporate conferences to small trade shows as well as banquets, sporting events, seminars and more. It's an asset for the city for locals and visitors. For smaller gatherings, the Community Center is available. Event Center staff also manage Mardi Gras.

History: The Wharf built and opened a 20,000-square-foot conference center in 2008. In April 2011, the City purchased the Wharf Conference Center for \$1.6 million, gaining immediate equity in the asset. Renamed the Orange Beach Event Center at The Wharf, the City continues to aggressively recruit trade shows, conferences, meetings, concerts and more to bring attendees to town to fill room nights in the City. The adjacent 132-room Marriott Springhill Suites hotel on The Wharf site has enhanced the value of the Event Center, which remains booked year round.

Hours: Office: Monday-Friday, 8 a.m.-4 p.m.

Phone: 251-981-6629

Website: <https://www.orangebeachal.gov/353/Event-Center>

Staff: 5 full-time employees, 2-3 (seasonal) part-time employees

Director: Angela Bateman

Budget: \$692,463

Revenue: \$165,000

Expenses: \$692,463

Reason for 2026 budget increase: Slight increase in operating expenses due to more use of Part time employees. We need more assistance in setting up and breaking down during busy seasons (September through mid December and January through mid May). The large increase is in Capital expenses. Event Center has spent minimal amounts on capital expenditures over the past few years and it is crucial that the stage be replaced as the current stage has been mended as much as is safe; the current video matrix has to be repaired and upgraded as various components no longer "speak" with one another; and the sidewalk in the parking lot is not ADA compliant and is a major liability.

Features:

- With 18,000 square feet of rentable space, the Event Center can be configured in a variety of ways to serve various-sized meetings, exhibits, and receptions. The Event Center can accommodate from 25 to 2500 people.

Orange Beach Community Center

Purpose: Included in the Event Center budget is the Orange Beach Community Center. It is geared towards hosting City programs and serves as a rental facility for smaller community events and gatherings.

History: The Community Center was built by the early families of Orange Beach in the 1950s and served as a general meeting place. The City leased the building from the Community Center board in the early 1990's and in 2022 the Orange Beach Community Center Corporation officially donated the building and the land to the City of Orange Beach.

Hours: unstaffed facility

Phone: 251-981-3231 (Kristin Wong, staff person responsible for booking)

Website: <https://www.orangebeachal.gov/353/Community-Center>

Staff: Event Center staff operate facility as needed

Director: Angela Bateman

Features:

- The Community Center is a 5,000-square-foot facility that can accommodate approximately 300 people and is available for meetings, events and parties.

2026 Budget Totals

Department	2025 Budget	2026 Budget	Inc/(Dec)
411 Event Center			
411-681-401 SALARIES	304,886	372,711	67,825
411-681-402 OVERTIME	7,500	7,500	0
411-681-460 RETIREMENT	20,742	28,516	7,774
411-681-470 FICA	23,898	29,086	5,188
411-681-490 SUTA	175	250	75
411-681-507 EQUIPMENT/SMALL	30,000	30,000	0
411-681-510 GAS/OIL	5,000	5,000	0
411-681-513 SUPPLIES/JANITORIAL	13,500	15,000	1,500
411-681-516 SUPPLIES/OPERATING	20,000	20,000	0
411-681-540 UNIFORMS	1,750	2,000	250
411-681-605 COMMUNICATIONS	10,000	35,000	25,000
411-681-608 DUES/MBRSHIPS/SUBSCRIPTIONS	400	400	0
411-681-612 PROFESSIONAL FEES	2,000	2,000	0
411-681-614 RENTALS	2,000	2,000	0
411-681-616 RPR/MAINT BUILDING	50,000	50,000	0
411-681-618 RPR/MAINT EQUIPMENT	10,000	10,000	0
411-681-620 RPR/MAINT GROUNDS	2,000	2,000	0
411-681-622 RPR/MAINT VEHICLES	3,000	3,000	0
411-681-630 TRAINING/TRAVEL	4,000	8,000	4,000
411-681-635 UTILITIES	77,000	60,000	(17,000)
411-681-650 EXHIBITS & PROMOTIONS	10,000	10,000	0
411-681-710 BUILDING UPGRADES	0	0	0
411-681-730 CAPITAL EQUIPMENT	0	0	0
411 Event Center Subtotal	597,851	692,463	94,612



Art Gallery/Hot Shop Studio/Clay Studio/Kids Studio
A "Quality of Life" facility for the community.

Purpose: Art Education for children and adults | Community Experiences | Event Venue
History: Previously located in an old home with foundation damage. The home was taken down in 2014. A new gallery was designed and built with the doors opening in August of 2017.
Hours: 9 a.m.-4 p.m., Monday-Friday
Staff: 11 full-time employees
Director: Desiree Hodge
Budget: *Revenue: \$730,000*
Expenses: \$1,403,453

Reason for 2026 budget increase: Increase is due to hot shop renovation in the amount of \$200,000

Features:

- Personalized glass blowing and clay classes.
- Homeschool classes and After School classes.
- Adult visual art classes.
- Concert series: "Acoustic Arts" in Jan/Feb; Frank Brown Int'l Songwriters Fest partner in Nov.
- Featured art exhibits and artist receptions
- "Best of the Vets" art contest in November for Veterans
- Three summer art camps for children.

Events:

- Orange Beach Festival of Art, 2nd weekend in March
- Baldwin Pops concert, September
- Arts Afire, October
- Locals Art day, November
- Light Up The Arts, December

Venue Space:

- Weddings
- Rehearsal dinners
- Corporate outings
- Meeting space
- Memorial services
- Galas/Fundraisers
- Community use of grounds

2026 Budget Totals

Department	2025 Budget	2026 Budget	Inc/(Dec)
430 Art			
430-682-401 SALARIES	567,183	575,000	7,817
430-682-402 OVERTIME	10,500	10,500	0
430-682-460 RETIREMENT	35,000	43,913	8,913
430-682-470 FICA	44,193	44,791	598
430-682-490 SUTA	210	250	40
430-682-507 EQUIPMENT/SMALL	40,000	40,000	0
430-682-510 GAS/OIL	500	500	0
430-682-513 SUPPLIES/JANITORIAL	4,000	5,000	1,000
430-682-516 SUPPLIES/OPERATING	24,000	26,000	2,000
430-682-605 COMMUNICATIONS	10,800	11,300	500
430-682-608 DUES/MEMBERSHIP/SUBSCRIPT/LEASE	0	2,500	2,500
430-682-612 PROFESSIONAL FEES	49,000	51,000	2,000
430-682-614 RENTALS	71,750	77,000	5,250
430-682-616 RPR/MAINT PLANT/BLDGS	15,000	220,000	205,000
430-682-618 RPR/MAINT EQUIPMENT	9,000	8,000	(1,000)
430-682-620 RPR/MAINT GROUNDS	9,500	8,500	(1,000)
430-682-622 RPR/MAINT VEHICLES	1,500	1,500	0
430-682-630 TRAINING/TRAVEL	3,200	3,200	0
430-682-635 UTILITIES	60,000	61,000	1,000
430-682-649 FESTIVALS EXPENSES	35,000	37,500	2,500
430-682-650 EXHIBITIONS & PROMOTIONS	20,500	21,000	500
430-682-659 RESALE INV/CENTER	30,000	30,000	0
430-682-660 RESALE INV/ARTISTS	125,000	125,000	0
430-682-661 SALES TAX PAID	0	0	0
430 Art Subtotal	1,165,836	1,403,453	237,618



Orange Beach Public Library

Purpose: The Orange Beach Public Library's mission is to provide the community free and open access to the trained professional personnel, information, materials, and services they need for life-long learning, civic engagement, entertainment, and the exchange of ideas.

History: Established in 1992, the Library operates under a unique model and is not unusual in the library world (Fairhope follows a similar model): we are part of the City of Orange Beach, but also a separate entity governed by a five-member Library Board. About 95% of our funding comes from the City, with the remaining support provided by grants, state funding, and our Friends of the Library - a 501(c)(3) nonprofit.

The Library Board hires and evaluates the Director, sets library policies, and oversees the Library's mission. In turn, the Director wears many hats (HR, PR and community engagement, budget manager, grant writer, acquisitions specialist, IT support, and more) while the rest of the staff have their overarching roles but are cross-trained to provide coverage in all areas.

Membership & Collaboration: We are part of the Baldwin County Library Cooperative, which provides daily courier service for materials shared among member libraries. Serving an average of 120,000 visitors annually, Orange Beach Public Library keeps pace with larger county libraries such as Foley, Daphne, and Fairhope, all of which serve populations at least twice as large as ours. We are tiny but mighty!

Hours: Monday, Tuesday, Wednesday, Friday: 9 a.m.–6 p.m.
Thursday: 9 a.m.–8 p.m.
Saturday: 9 a.m.–3 p.m.

Phone: 251-981-2923

Website: <https://www.orangebeachlibrary.gov>

Staff: 8 full-time employees

Director: Meagan Bing

Budget: \$846,276

Revenue: **

***Libraries aren't revenue-generating organizations in the traditional sense. But we do offer a lot for our community! ROI for OBPL= Value of Services ÷ Library Budget.*

2025 ROI = \$2,235,408 ÷ \$749,974 ≈ \$2.98

For every \$1 invested in the library, the community received almost \$3 in services and resources.

Reason for 2026 budget increase: After several years of level funding, the Library's FY2026 budget

request reflects a necessary increase driven by essential building and security upgrades requested by the City, the loss of external funding sources, an anticipated reduction in State Aid, and the impact of inflation. This increase ensures we can continue providing the high-quality service our community expects while preparing for future needs.

Features: The library actively offers educational, cultural, and recreational programs for residents and visitors of all ages. Ongoing initiatives include children's outreach to local schools and daycares, partnering with City departments and community organizations for outreach and special events, as well as in-house storytimes, arts and crafts

sessions for all ages, technology classes, books clubs and community outreach. In addition, the library continues to expand its technology access with our Makerspace and individualized services such as proctored tests, one-on-one technology training, and “Book-a-Librarian” appointments.



**REGULAR CITY COUNCIL MEETING
DECEMBER 16, 2025**

Departments: City Clerk

Description of Topic: Resolution authorizing the city to host community events for the benefit of citizens and visitors of the City of Orange Beach during 2026.

Background/Description:

Action Options/Recommendation:

Source of Funding (if applicable):

ATTACHMENTS:

1. 12-16-25 25-xxx Authorize Community Events 2026

RESOLUTION NO. 25-xxx

**A RESOLUTION AUTHORIZING THE CITY TO HOST
COMMUNITY EVENTS FOR THE BENEFIT OF CITIZENS AND VISITORS
OF THE CITY OF ORANGE BEACH DURING 2026**

FINDINGS:

1. The City hosts certain annually held events for the benefit of its citizens and visitors, specifically, the City Mardi Gras Parade, the Art Festival, the Seafood Fest at The Wharf, Parks and Recreation Month Events, Live at Waterfront Park Music Series, Freedom Fest at The Wharf, and the City Christmas Tree Lighting Event at The Wharf. These events are important to the local economy as well as to the general welfare and spirit of the community.
2. The City wishes to host the above stated events during the calendar year 2026.
3. The following personal property owned by the City of Orange Beach, Alabama, is no stated events will promote tourism and local businesses, stimulate economic growth in the community and provide benefit to the City's economy.
4. The events serve a public purpose by promoting the health, safety, morals, security, prosperity, contentment, and general welfare of the community.
5. The stated events will provide quality-of-life benefits to the community by bringing the community together, celebrating and enhancing the spirit of community.
6. The City Council has determined that providing such events serves a public purpose and is in the best interest of the citizens and visitors of the City of Orange Beach, Alabama.

NOW, THEREFORE, BE IT RESOLVED BY THE CITY COUNCIL OF THE CITY OF ORANGE BEACH, ALABAMA, AS FOLLOWS:

1. That the Orange Beach City Council, having determined that it serves a public purpose and is in the best interest of the City, hereby authorizes the use of certain public resources for the purpose of hosting annual community events in the City of Orange Beach, namely the City Mardi Gras Parade, the Art Festival, the Seafood Fest at The Wharf, Parks and Recreation Month Events, Live at Waterfront Park Music Series, Freedom Fest at The Wharf, and the City Christmas Tree Lighting Event at The Wharf;
2. That the Mayor be and is hereby authorized to sign such agreements as may be necessary for expending funds to host the events and/or for hosting the events generally; and
3. That this Resolution shall become effective immediately upon its adoption and remain effective until its expiration on December 31, 2026.

ADOPTED THIS 16th DAY OF DECEMBER, 2025.

Renee Eberly
City Clerk

C E R T I F I C A T E

I, Renee Eberly, City Clerk of the City of Orange Beach, Alabama, do hereby certify that the foregoing is a true and correct copy of Resolution No. 25-xxx, which was duly and legally adopted at a regular meeting of the City Council on December 16, 2025.

City Clerk



**REGULAR CITY COUNCIL MEETING
DECEMBER 16, 2025**

Departments: City Clerk

Description of Topic: Resolution authorizing the execution of a performance contract with Anne Gajda for golf instruction services.

Background/Description:

Action Options/Recommendation:

Source of Funding (if applicable):

ATTACHMENTS:

1. 12-16-25 25-xxx Authorize Performance Contract Golf Pro Anne Gajda
2. 2025.11.18 Performance Contract Anne Gajda Golf

RESOLUTION NO. 25-xxx

**A RESOLUTION AUTHORIZING THE EXECUTION OF A
PERFORMANCE CONTRACT WITH
ANNE GAJDA FOR GOLF INSTRUCTION SERVICES**

FINDINGS:

1. The City of Orange Beach and Anne Gajda have reached an agreement (attached Exhibit A) whereby Anne Gajda will provide golf instruction services for the City of Orange Beach.
2. After having reviewed the agreement, the City Council has determined that the provisions are in the best interest of the City of Orange Beach, Alabama.

NOW, THEREFORE, BE IT RESOLVED BY THE CITY COUNCIL OF THE CITY OF ORANGE BEACH, ALABAMA, AS FOLLOWS:

1. That the Mayor is hereby authorized to execute the agreement in substantially the form and of substantially the content now before the Council between the City of Orange Beach and Anne Gajda as an act for and on behalf of the City of Orange Beach subject to final approval by the City Attorney; and
2. That this Resolution shall become effective immediately upon its adoption.

ADOPTED THIS 16th DAY OF DECEMBER, 2025.

Renee Eberly
City Clerk

C E R T I F I C A T E

I, Renee Eberly, City Clerk of the City of Orange Beach, Alabama, do hereby certify that the foregoing is a true and correct copy of Resolution No. 25-xxx, which was duly and legally adopted at a regular meeting of the City Council on December 16, 2025.

City Clerk

PERFORMANCE CONTRACT

This Agreement is made and entered into by and between the City of Orange Beach, an Alabama municipal corporation (the “City”) and Anne Gajda (sometimes hereinafter “Contractor”), as follows:

1. Recitals:

- a. Contractor is a golf teacher who provides instruction.
- b. The City desires to engage Contractor to provide such services for the benefit of Orange Beach residents and visitors.
- c. In consideration of the mutual covenants and agreements hereinafter set forth to be kept and performed by the other, and other good and valuable consideration, the receipt and sufficiency of all of which are hereby acknowledged, the parties do hereby covenant and agree as follows.

2. Contractor’s Obligations:

- a. Contractor shall offer golf lessons, and related skill-development classes at the Orange Beach Golf Center.
- b. Contractor shall provide, at no charge at least twenty hours a year of golf instruction for the City’s Expect Excellence Program and/or the public schools within the City of Orange Beach.
- c. Contractor must have an Orange Beach Business License.
- d. Contractor will schedule lesson times with the Orange Beach Golf Center prior to the lessons.
- e. Contractor will assist with open houses and small programs for the Golf Center.
- f. Contractor shall maintain a limit of 10 people per group lesson and 2 baskets of balls for the driving range. This limit is essential to ensure that all participants have sufficient space on the range and that the range is shared equitably with members, programs, and other contractors.

3. City’s Obligations:

- a. City agrees to make available during normal operational hours an agreed portion of the range for the Contractor to provide lessons. (Morning time for (10 people) during group lessons).
- b. City will provide an indoor space (Simulator room) during weather events. Contractor will schedule lesson times in this space with the Orange Beach Golf Center and it is subject to availability.

4. Compensation:

Contractor will be permitted to retain the fees earned for the instructional services provided under this Agreement.

5. Term:

The term of this agreement shall begin on December 1, 2025, and end on April 30, 2026, unless terminated earlier in accordance with paragraph 10. This agreement may be renewed annually by resolution adopted by the City Council.

6. Independent Contractor:

- a. Notwithstanding any of the provisions of this Agreement, it is agreed that City has no financial interest in the business of Contractor and shall not be liable for any debts or obligations incurred by Contractor, nor shall City be deemed or construed to be a partner, joint venturer or otherwise interested in the assets of Contractor, or in the sums earned or derived by Contractor, nor shall

Contractor at any time or times use the name or credit of City in purchasing or attempting to purchase any car, equipment, supplies or other thing or things whatsoever.

- b. Contractor, in the performance of its operations and obligations hereunder, shall not be deemed to be an agent of City but shall be deemed to be an Independent Contractor in every respect and shall take all steps at its own expense, as City may from time to time request, to indicate that it is an Independent Contractor. City does not and will not assume any responsibility for the means by which or the manner in which the services by Contractor provided for herein are performed, but on the contrary, Contractor shall be wholly responsible therefor.

7. Assignment:

Contractor acknowledges that its identity and peculiar capacity to provide the services described hereinabove constitute a material consideration for City's having entered into this Agreement. Therefore, Contractor shall not transfer or assign this Agreement or any of the rights or privileges granted herein without the prior written consent of City; which such consent shall be granted or denied solely at City's discretion.

8. Insurance:

- a. Contractor shall procure and maintain, at its own cost, a policy or policies of insurance sufficient to insure against all liability, claims, demands, and other obligations assumed by Contractor under this Agreement, including the following, at a minimum:
 - i. Worker's compensation insurance as required by law; and
 - ii. Commercial general liability insurance with minimum coverage limits of \$100,000 per person and \$300,000 per occurrence, naming the City of Orange Beach and the City's officers, employees, and consultants as additional insured. The policy shall be with a carrier and in a form acceptable to the City at the City's sole discretion.
- b. Any insurance carried by the City, its officers, or its employees or contractors is excess and not contributory insurance to that provided by Contractor. Contractor shall be solely responsible for any deductible losses under any policy.
- c. Contractor shall provide to the City a Certificate of Insurance as evidence that required policies are in full force and effect.

9. Indemnity:

Contractor agrees to indemnify and hold the City, its elected and appointed officials, officers, agents, and employees, harmless from all costs, liabilities and claims for damages of any kind, including interest and attorneys' fees, arising in any way out of the performance of this Agreement and/or the activities of Contractor, its principals, directors, agents, servants and employees in the performance of this Agreement, for which the City is alleged to be liable. This section is not as to third parties or to anyone a waiver of any defense of immunity or statutory damages cap otherwise available to Contractor or City and these defenses and matters may be raised in the City's behalf in any action or proceeding arising from this Agreement.

10. Compliance with Law:

Contractor hereby agrees to comply strictly with all the laws of the State of Alabama and of the United States, and the laws and ordinances of any other jurisdiction in which contractor may perform any work pursuant to this agreement.

11. Termination:

This agreement may be terminated by either party for any reason upon thirty (30) days notice of the intent to terminate.

12. Final Agreement:

This Agreement is the final expression of the agreement between the parties, and the complete and exclusive statement of the terms agreed upon, and shall supersede all prior negotiations, understandings or agreements. There are no representations, warranties, or stipulations, either oral or written, not contained herein.

13. Modifications:

Any alterations, variations, modifications, or waivers of the provisions of this Agreement shall only be valid when they have been reduced to writing and signed by authorized representatives of the party against whom enforcement is sought.

14. Severability:

The provisions of this Agreement shall be deemed severable. If any part of this Agreement is rendered void, invalid or unenforceable, such rendering shall not affect the enforceability of the remainder of this Agreement unless the part or parts which are void, invalid or otherwise unenforceable shall substantially impair the value of the entire agreement with respect to any party.

15. Laws Governing:

This Agreement shall be governed by the laws of the State of Alabama, and the appropriate venue for any actions arising out of this Agreement would be Baldwin County, Alabama.

16. Permits, Licensing, etc:

Contractor shall obtain, at its own expense, all necessary licenses, permits, insurance, authorizations and assurances necessary in order to abide by the terms of this Agreement.

17. Confidentiality:

Contractor (including its employees, agents, subcontractors) acknowledges that all confidential business and personal information ("Protected Information") that it may obtain while performing services for the City, is deemed confidential and proprietary to the City. During Contractor's tenure with the City, Contractor agrees to use Protected Information only and strictly as required to perform its services on behalf of the City. Contractor will not disclose Protected Information to any person or entity without the prior written consent of the City and the written agreement of any third party. Contractor agrees to refer any request for public information or records to the City Clerk, who is the custodian of records for the City and is responsible for the disclosure of public records in accordance with the public records laws of the state. Contractor agrees that it will not duplicate or incorporate Protected Information into its own records or databases and that after the conclusion of its services to the City all Protected Information in the Contractor's possession will be turned over to the City. Contractor agrees not to disclose, use, transfer, or transmit the information to any person or entity for any purpose whatsoever. This includes records, passwords, access codes, manuals, statistics, software, audio/video recordings, or storage disks of any kind containing Protected Information.

18. Notices:

All notices of cancellation, requests, demands, or other communications shall be in writing and duly delivered to the addresses appearing below.

City of Orange Beach:

City Clerk
Post Office Box 458

Orange Beach, Alabama 36561

With Required Copy to:

City Attorney
Post Office Box 458
Orange Beach, Alabama 36561

And to Contractor:

Anne Gajda
8072 Park Lane
Ypsilanti, MI 48198

IN WITNESS WHEREOF, we have hereunto set our hands and seal on this the _____ day of _____, 2025.

CITY OF ORANGE BEACH,
An Alabama Municipal Corporation

By: _____
Mayor Anthony T. Kennon

ATTEST:

Renee Eberly, City Clerk

CONTRACTOR:

ANNE GAJDA

By: _____
Anne Gajda

STATE OF ALABAMA
COUNTY OF BALDWIN

I, the undersigned Notary Public in and for said County in said State, hereby certify that Tony Kennon and Renee Eberly, whose names as Mayor and City Clerk, respectively, of the City of Orange Beach, an Alabama Municipal Corporation, are signed to the foregoing agreement, and who are known to me, acknowledged before me on this day, that, being informed of the contents of the above and foregoing, they, as such officers and with full authority, executed the same voluntarily for and as the act of said municipal corporation on the day the same bears date.

Given under my hand and seal on the _____ day of _____, 2025.

(SEAL)

Notary Public
My Commission Expires: _____

STATE OF ALABAMA
COUNTY OF BALDWIN

I, the undersigned Notary Public in and for said County in said State, hereby certify that Anne Gajda is signed to the foregoing agreement, and who is known to me, acknowledged before me on this day, that, being informed of the contents of the above and foregoing, she, as such owner and with full authority, executed the same voluntarily for and as the act of said municipal corporation on the day the same bears date.

Given under my hand and seal on the _____ day of _____, 2025.

(SEAL)

Notary Public
My Commission Expires: _____



**REGULAR CITY COUNCIL MEETING
DECEMBER 16, 2025**

Departments: City Clerk

Description of Topic: Resolution authorizing the execution of a performance contract with Joan Hill for water aerobics instruction at the Aquatics Center.

Background/Description:

Action Options/Recommendation:

Source of Funding (if applicable):

ATTACHMENTS:

1. 12-16-25 25-xxx Authorize Performance Contract Water Aerobics Instructor Joan Hill
2. 2025.11.26 Performance Contract Joan Hill Water Aerobics Instructor

RESOLUTION NO. 25-xxx

**A RESOLUTION AUTHORIZING THE EXECUTION OF A
PERFORMANCE CONTRACT WITH
JOAN HILL FOR WATER AEROBICS INSTRUCTION
AT THE AQUATICS CENTER**

FINDINGS:

1. The City of Orange Beach wishes to engage independent contractors to provide various fitness classes for the benefit of Orange Beach residents and visitors.
2. Joan Hill is a certified water aerobics instructor who wishes to teach classes at the Orange Beach Aquatics Center.
3. The City of Orange Beach and Joan Hill have reached an agreement (attached Exhibit A) whereby the City of Orange Beach agrees to pay Joan Hill to lead water aerobics classes at the Orange Beach Aquatics Center.
4. After having reviewed the agreement, the City Council has determined that the provisions are in the best interest of the City of Orange Beach, Alabama.

NOW, THEREFORE, BE IT RESOLVED BY THE CITY COUNCIL OF THE CITY OF ORANGE BEACH, ALABAMA, AS FOLLOWS:

1. That the Mayor is hereby authorized to execute the agreement in substantially the form and of substantially the content now before the Council between the City of Orange Beach and Joan Hill as an act for and on behalf of the City of Orange Beach subject to final approval by the City Attorney; and
2. That this Resolution shall become effective immediately upon its adoption.

ADOPTED THIS 16th DAY OF DECEMBER, 2025.

Renee Eberly
City Clerk

C E R T I F I C A T E

I, Renee Eberly, City Clerk of the City of Orange Beach, Alabama, do hereby certify that the foregoing is a true and correct copy of Resolution No. 25-xxx, which was duly and legally adopted at a regular meeting of the City Council on December 16, 2025.

City Clerk

PERFORMANCE CONTRACT

This Agreement is made and entered into by and between the City of Orange Beach, an Alabama municipal corporation (the “City”) and Joan Hill (sometimes hereinafter “Contractor”), as follows:

1. Recitals.

- a. Contractor is a water aerobics instructor who provides instruction.
- b. The City desires to engage Contractor to provide such services for the benefit of Orange Beach residents and visitors.
- c. In consideration of the mutual covenants and agreements hereinafter set forth to be kept and performed by the other, and other good and valuable consideration, the receipt and sufficiency of all of which are hereby acknowledged, the parties do hereby covenant and agree as follows.

2. Contractor’s Obligations.

- a. Contractor shall offer water aerobics classes at the Orange Beach Aquatics Center
- b. Contractor must possess a current certification from (at least) one of the following nationally recognized certifying agencies: Aquatic Exercise Association (AEA), United States Water Fitness Association (USWFA), FiTour, and/or YMCA. (Certifications from organizations not listed may be accepted, pending approval by the Aquatics Facility Director).
- c. Contractor must have an Orange Beach Business License.
- d. Contractor will conduct each class scheduled, regardless of the number of participants present at the scheduled class time.
- e. Pre-determined cancellations must be decided no less than two hours prior to class time pursuant to the following policy:
 - i. Instructors may make recommendations for cancellations in cases of emergencies, illness, weather, or other unforeseen circumstances that may prevent them from conducting their scheduled classes.
 - ii. The final decision regarding cancellations will be made by the Aquatics Facility Director to ensure operational consistency.
 - iii. Instructor/s must notify the Aquatics Facility Director as soon as possible in the event of a potential cancellation. Advance notice allows for appropriate arrangements to be made to minimize disruption to the schedule.
 - iv. Whenever possible, substitute instructors should be used to minimize the impact on the community and ensure continuity of service.
 - v. Failure to adhere to this cancellation policy may result in penalties, including but not limited to a reduction in scheduled hours or termination of instructor’s contract.
 - vi. The City of Orange Beach reserves the right to cancel classes, combine or divide classes, change the time, date or place of classes, change the contract instructor and make other changes which become necessary for the best interests of the City and its participants.
- f. Contractor will hold classes for a minimum of fifty minutes.

3. City’s Obligations.

- a. City agrees to make available during normal operational hours lanes 5 and 6 and the deep end of the Aquatics Center for the Contractor to teach classes.
- b. City agrees to provide all necessary equipment for Contractor’s water aerobic classes.

4. Compensation.

Contractor will be paid at a fixed rate of \$30.00 per class on a bi-weekly basis. If inclement weather occurs during a class time, the current class will be cancelled, and the instructor will be paid for the full hour. This does not include pre-determined cancellations.

5. Term.

The term of this agreement shall begin on February 2, 2026, and end on November 30, 2026, unless terminated earlier in accordance with paragraph 11. This agreement may be renewed annually by resolution adopted by the City Council. Classes will not be held during the months of January and December.

6. Independent Contractor.

- a. Notwithstanding any of the provisions of this Agreement, it is agreed that City has no financial interest in the business of Contractor and shall not be liable for any debts or obligations incurred by Contractor, nor shall City be deemed or construed to be a partner, joint venturer or otherwise interested in the assets of Contractor, or in the sums earned or derived by Contractor, nor shall Contractor at any time or times use the name or credit of City in purchasing or attempting to purchase any car, equipment, supplies or other thing or things whatsoever.
- b. Contractor, in the performance of its operations and obligations hereunder, shall not be deemed to be an agent of City but shall be deemed to be an Independent Contractor in every respect and shall take all steps at its own expense, as City may from time-to-time request, to indicate that it is an Independent Contractor. City does not and will not assume any responsibility for the means by which or the manner in which the services by Contractor provided for herein are performed, but on the contrary, Contractor shall be wholly responsible therefor.

7. Assignment.

Contractor acknowledges that its identity and peculiar capacity to provide the services described hereinabove constitute a material consideration for City's having entered into this Agreement. Therefore, Contractor shall not transfer or assign this Agreement or any of the rights or privileges granted herein without the prior written consent of City; which such consent shall be granted or denied solely at City's discretion.

8. Insurance.

- a. Contractor shall procure and maintain, at its own cost, a policy or policies of insurance sufficient to insure against all liability, claims, demands, and other obligations assumed by Contractor under this Agreement, including the following, at a minimum:
 - i. Worker's compensation insurance as required by law; and
 - ii. Commercial general liability insurance with minimum coverage limits of \$100,000 per person and \$500,000 per occurrence, naming the City of Orange Beach and the City's officers, employees, and consultants as additional insured. The policy shall be with a carrier and in a form acceptable to the City at the City's sole discretion.
- b. Any insurance carried by the City, its officers, or its employees or contractors is excess and not contributory insurance to that provided by Contractor. Contractor shall be solely responsible for any deductible losses under any policy.
- c. Contractor shall provide to the City a Certificate of Insurance as evidence that required policies are in full force and effect.

9. Indemnity.

Contractor agrees to indemnify and hold the City, its elected and appointed officials, officers, agents, and employees, harmless from all costs, liabilities and claims for damages of any kind, including interest and attorneys' fees, arising in any way out of the performance of this Agreement and/or the activities of Contractor, its principals, directors, agents, servants and employees in the performance of this Agreement, for which the City is alleged to be liable. This section is not as to third parties or to anyone a waiver of any defense of immunity or statutory damages cap otherwise available to Contractor or City and these defenses and matters may be raised in the City's behalf in any action or proceeding arising from this Agreement.

10. Compliance with Law.

Contractor hereby agrees to comply strictly with all the laws of the State of Alabama and of the United States, and the laws and ordinances of any other jurisdiction in which contractor may perform any work pursuant to this agreement.

11. Termination.

This agreement may be terminated by either party for any reason upon one (1) week notice of the intent to terminate.

12. Final Agreement.

This Agreement is the final expression of the agreement between the parties, and the complete and exclusive statement of the terms agreed upon, and shall supersede all prior negotiations, understandings or agreements. There are no representations, warranties, or stipulations, either oral or written, not contained herein.

13. Modifications.

Any alterations, variations, modifications, or waivers of the provisions of this Agreement shall only be valid when they have been reduced to writing and signed by authorized representatives of the party against whom enforcement is sought.

14. Severability.

The provisions of this Agreement shall be deemed severable. If any part of this Agreement is rendered void, invalid or unenforceable, such rendering shall not affect the enforceability of the remainder of this Agreement unless the part or parts which are void, invalid or otherwise unenforceable shall substantially impair the value of the entire agreement with respect to any party.

15. Law Governing.

This Agreement shall be governed by the laws of the State of Alabama, and the appropriate venue for any actions arising out of this Agreement would be Baldwin County, Alabama.

16. Permits, Licensing, etc.

Contractor shall obtain, at its own expense, all necessary licenses, permits, insurance, authorizations and assurances necessary in order to abide by the terms of this Agreement.

17. Confidentiality.

Contractor (including its employees, agents, subcontractors) acknowledges that all confidential business and personal information ("Protected Information") that it may obtain while performing services for the City, is deemed confidential and proprietary to the City. During Contractor's tenure with the City, Contractor agrees to use Protected Information only and strictly as required to perform its services on behalf of the City. Contractor will not disclose Protected Information to any person or entity without the prior written consent of the City and the written agreement of any third party.

Contractor agrees to refer any request for public information or records to the City Clerk, who is the custodian of records for the City and is responsible for the disclosure of public records in accordance with the public records laws of the state. Contractor agrees that it will not duplicate or incorporate Protected Information into its own records or databases and that after the conclusion of its services to the City all Protected Information in the Contractor's possession will be turned over to the City. Contractor agrees not to disclose, use, transfer, or transmit the information to any person or entity for any purpose whatsoever. This includes records, passwords, access codes, manuals, statistics, software, audio/video recordings, or storage disks of any kind containing Protected Information.

18. Notices.

All notices of cancellation, requests, demands, or other communications shall be in writing and duly delivered to the addresses appearing below.

City of Orange Beach:

City Clerk
Post Office Box 458
Orange Beach, Alabama 36561

With Required Copy to:

City Attorney
Post Office Box 458
Orange Beach, Alabama 36561

And to Contractor:

Joan Hill
22595 Wedgewood Drive
Foley, AL 36535

IN WITNESS WHEREOF, we have hereunto set our hands and seal on this the _____ day of _____, 2025.

CITY OF ORANGE BEACH,
An Alabama Municipal Corporation

By: _____
Tony Kennon, Mayor

ATTEST:

Renee Eberly, City Clerk

CONTRACTOR

By: _____
Joan Hill

STATE OF ALABAMA

COUNTY OF BALDWIN

I, the undersigned Notary Public in and for said County in said State, hereby certify that Tony Kennon and Renee Eberly, whose names as Mayor and City Clerk, respectively, of the City of Orange Beach, an Alabama Municipal Corporation, are signed to the foregoing agreement, and who are known to me, acknowledged before me on this day, that, being informed of the contents of the above and foregoing, they, as such officers and with full authority, executed the same voluntarily for and as the act of said municipal corporation on the day the same bears date.

Given under my hand and seal on the _____ day of _____, 2025.

(SEAL)

Notary Public
My Commission Expires: _____

STATE OF ALABAMA
COUNTY OF BALDWIN

I, the undersigned Notary Public in and for said County in said State, hereby certify that Joan Hill is signed to the foregoing agreement, and who is known to me, acknowledged before me on this day, that, being informed of the contents of the above and foregoing, she executed the same voluntarily on the day the same bears date.

Given under my hand and seal on the _____ day of _____, 2025.

(SEAL)

Notary Public
My Commission Expires: _____



**REGULAR CITY COUNCIL MEETING
DECEMBER 16, 2025**

Departments: City Clerk

Description of Topic: Resolution to update the list of volunteer firefighters and reserve police officers covered under workers' compensation insurance.

Background/Description:

Action Options/Recommendation:

Source of Funding (if applicable):

ATTACHMENTS:

1. 12-16-25 25-xxx Workers Comp Update Fire Police

RESOLUTION NO. 25-xxx

**A RESOLUTION TO UPDATE THE LIST OF
VOLUNTEER FIREFIGHTERS AND RESERVE POLICE OFFICERS
COVERED UNDER WORKERS' COMPENSATION INSURANCE**

BE IT RESOLVED BY THE CITY COUNCIL OF THE CITY OF ORANGE BEACH, ALABAMA, AS FOLLOWS:

1. That the following listed reserve police officers are hereby covered by the City's workers' compensation insurance when said individuals are on duty as police personnel:

Alexander Bischoff
Douglas Malcolm Cole
Khyle Douglas Jackson
Shawn Lambert Temple
Terry Lynn Waldrop

The following are city employees who serve as reserve police officers:

Matthew Tyler Malone Finance Department
Kevin Lanford Fire Department

The following are reserve auxiliary police officers who do not carry a weapon:

Norman Robert Matzl
Bruce David McNelly

2. That the City of Orange Beach currently does not have volunteer firefighters to be covered by workers' compensation insurance;
3. That these lists will be updated annually by a vote of the City Council; and
4. That this Resolution shall become effective immediately upon its adoption.

ADOPTED THIS 16th DAY OF DECEMBER, 2025.

Renee Eberly
City Clerk

C E R T I F I C A T E

I, Renee Eberly, City Clerk of the City of Orange Beach, Alabama, do hereby certify that the foregoing is a true and correct copy of Resolution No. 25-xxx, which was duly and legally adopted at a regular meeting of the City Council on December 16, 2025.

City Clerk



**REGULAR CITY COUNCIL MEETING
DECEMBER 16, 2025**

Departments: City Clerk

Description of Topic: Resolution authorizing the execution of retainer agreements for outside counsel for the City of Orange Beach for 2026.

Background/Description:

Action Options/Recommendation:

Source of Funding (if applicable):

ATTACHMENTS:

1. 12-16-25 25-xxx Authorize Retainer Agreements Attorneys 2026
2. 2025.12.02 Letter of Engagement - Attorney Canupp
3. 2025.12.02 Letter of Engagement - Attorney Rutens
4. 2025.12.02 Letter of Engagement - Attorney Woodall
5. 2025.12.02 Letter of Appointment - Attorney Davis

RESOLUTION NO. 25-xxx

**A RESOLUTION AUTHORIZING THE EXECUTION OF RETAINER AGREEMENTS
FOR OUTSIDE COUNSEL FOR THE CITY OF ORANGE BEACH FOR 2026**

FINDINGS:

1. Chapter 2, Section 83 of the *Code of Ordinances for the City of Orange Beach* authorizes the City Attorney, with consent of the Mayor to appoint such other attorneys as are needed to carry on the legal business of the City with retainer agreements approved by the Council.
2. The City Attorney has recommended that:
 - a. Attorney Spencer E. Davis, Jr., be appointed as the City Prosecutor for Municipal Court;
 - b. Attorney Paul Woodall of the Jones Walker law firm in Birmingham be appointed to represent the City concerning real estate transactions, public finance, economic incentives, and other specialized legal services as may be directed by the City Attorney;
 - c. Attorney David Canupp of Lanier Ford Shaver & Payne, P.C. law firm in Huntsville, Alabama be appointed to represent the City concerning issues related to the City sign ordinance, employment law, and other specialized legal services as may be directed by the City Attorney; and
 - d. The law firm of Galloway, Wettermark & Rutens, LLP, be appointed to represent the City concerning specialized legal services as may be directed by the City Attorney.
3. The City Attorney has reviewed the attached retainer agreements and recommends approval of same.
4. The term of these agreements shall be for twelve (12) months commencing January 1, 2026, and ending December 31, 2026.
5. After reviewing the attached retainer contracts, the City Council has determined that the provisions are in the best interest of the City of Orange Beach, Alabama.

NOW, THEREFORE, BE IT RESOLVED BY THE CITY COUNCIL OF THE CITY OF ORANGE BEACH, ALABAMA, AS FOLLOWS:

1. That the Mayor is hereby authorized to execute the attached retainer agreements in substantially the form and of substantially the content now before the Council as an act for and on behalf of the City of Orange Beach, Alabama subject to final approval by the City Attorney; and
2. That this Resolution shall become effective upon its adoption.

ADOPTED THIS 16th DAY OF DECEMBER, 2025.

Renee Eberly
City Clerk

C E R T I F I C A T E

I, Renee Eberly, City Clerk of the City of Orange Beach, Alabama, do hereby certify that the foregoing is a true and correct copy of Resolution No. 25-xxx, which was duly and legally adopted at a regular meeting of the City Council on December 16, 2025.

City Clerk



LANIER FORD SHAVER & PAYNE P.C.
Attorneys at Law
2101 West Clinton Avenue, Suite 102 / 35805
Mailing Address:
Post Office Box 2087 · Huntsville, Alabama 35804

256-535-1100 Office
256-533-9322 Fax
www.LanierFord.com

David J. Canupp
djc@lanierford.com

December 2, 2025

Via Email Only

[\[jlogan@orangebeachal.gov\]](mailto:jlogan@orangebeachal.gov)

Jamie Logan, City Attorney
City of Orange Beach
P. O. Box 458 | 4099 Orange Beach Blvd.
Orange Beach, AL 36561

RE: Engagement for Performance of Professional Services

Dear Jamie:

This letter, and the attached terms and conditions, will confirm your engagement of this firm's services for the purpose of providing general legal advice and services related to general employment matters. Our services will be billed on an hourly basis. My hourly rate, and that of other shareholders in our firm, is \$315.00 per hour. The hourly rate for associate attorney work is \$285.00 and the rate for paralegal work is \$125.00 per hour.

Additional terms and conditions of this representation are set out in more detail in the enclosed Terms and Conditions document. If you find the terms of this representation satisfactory, please respond by either signing the consent section at page two of this letter and returning it to me, or sending me an e-mail indicating that you accept the terms provided herein. Such an acknowledgment and acceptance of the terms will provide me with the written consent from you that allows me to proceed with the representation.

I greatly appreciate the opportunity to assist you with your legal matters. If you have any questions or concerns whatsoever, please do not hesitate to give me a call.

Yours very truly,

LANIER FORD SHAVER & PAYNE P.C.

A handwritten signature in black ink that reads 'David J. Canupp'.

David J. Canupp

DJC/kc

December 2, 2025
Page 2

I hereby accept the terms and conditions of representation as outlined in the engagement letter provided to me and the appended Terms and Conditions document, and I authorize Lanier Ford Shaver & Payne, P.C. to commence the contemplated services.

Signature

REPRESENTATION AGREEMENT

This representation agreement ("Agreement") is entered into between the City of Orange Beach, Alabama ("Client") and the law firm of Galloway, Wettermark & Rutens, LLP ("Firm"). Client hereby engages Firm to represent Client from time to time on an as-needed basis, as authorized by the City Attorney or City Administrator.

Fees and Billing: In consideration of said representation, Client agrees to pay to Firm an attorney fee as follows:

- a. \$195 per hour of service by attorneys at the Firm, , and
- b. \$75.00 per hour of paralegal service, and

Client further agrees to pay all reasonable expenses incurred by Firm in representing Client, including but not limited to, all court fees, court reporter and/or videographer expenses, travel expenses, expert witness fees, research fees, copy service expense, in-house copy expenses, trial exhibit expenses and other such reasonable expenses. Such expenses shall be paid directly by Client or, if the firm elects to advance the expense(s), Client agrees to repay the same within thirty (30) days of being invoiced by the Firm.

Client agrees that all invoices for fees and/or expenses will be billed periodically and Client agrees to pay each bill in full within thirty (30) days from the date of mailing to Client by the Firm.

The Firm does not require a retainer, but may condition future legal representation services upon receipt of a reasonable retainer within twenty (20) days of request.

Termination of representation: Client has the right to terminate our services at any time. If you decide to terminate our services, you agree to give us prompt written notice of such termination. Upon our termination, you will remain obligated to pay for all services rendered and costs or expenses paid or incurred on your behalf prior to the date of such termination or which are reasonably necessary thereafter.

The Firm has the right to withdraw from this representation if, among other things, the Client fails to honor the terms of this engagement agreement, fails to make

payment of any statements in a timely manner, fails to cooperate or to follow the Firm's advice on a material matter, or any fact or circumstance occurs that would, in the Firm's view, render its continuing representation inappropriate, unlawful or unethical and the Firm determines that it is permitted to withdraw from representation. If the Firm elects to withdraw, the Client will take all steps necessary to free the Firm of any obligation to perform further services, including the execution of any documents necessary to complete the Firm's withdrawal. Notwithstanding such termination, the Client will remain obligated to pay for all services provided and to reimburse the Firm for all costs and expenses paid or incurred on the Client's behalf.

The Firm does not believe that its representation of Client will lead to any conflicts of interest or that any event or circumstance would otherwise compromise our ability to adequately represent Client or any other current or past clients of the Firm. Nevertheless, should such a conflict or event or circumstance arise, it is agreed that the Firm may withdraw from its representation of Client, upon seven days' notice, and Client agrees to support a motion, if filed by the Firm, to withdraw from our representation if resignation at that time is otherwise permissible under applicable professional rules.

Disputes: Client agrees that, if a dispute between the Firm and Client arises out of or related to or connected with in any way the Firm's representation of Client, Client waives the right to a trial by jury, and Client agrees that venue shall be in Mobile County, Alabama. If this waiver of the right to trial by jury is held invalid (or if the parties agree in writing) such dispute shall be resolved by a single neutral arbitrator who is an attorney licensed to practice in Mobile County, Alabama who is selected by the Presiding Judge of Mobile Circuit Court, and under such rules of discovery and evidence as the arbitrator may establish, with each party bearing its/his own costs and attorney fees. This Agreement constitutes the entire agreement between the parties. The parties agree that this Agreement will be construed according to the laws of the State of Alabama, excluding any choice of law principles under Alabama law.

Document Retention/Destruction: In the course of our representation of you, we

may come into possession of copies or originals of documents or other materials belonging to you or others (collectively, "materials"). In the absence of any other arrangements made with you, the Firm's records retention policy provides that upon the expiration of the period of time set forth by the Alabama State Bar after a matter has been closed (currently six years), all materials in the file may be destroyed or discarded without notice to you, except for "Category 1" documents or other "intrinsically valuable property," which either will be retained by Firm or returned to Client. Accordingly, if there are any documents or other materials you wish to have retrieved from your file at the conclusion of a matter, it will be necessary for you to advise us of that request to ensure that they are not destroyed.

Entire Agreement: This Agreement supersedes all other prior and contemporaneous written and oral agreements and understandings between us and contain the entire agreement between the parties. This agreement may be modified only by subsequent written agreement of the parties. You acknowledge that no promises have been made to you other than those stated in this agreement.

Severability: If any portion of this Agreement is determined by any court or arbitrator to be illegal or invalid, the validity of the remaining terms of the Agreement shall not be affected and said illegal or invalid portion shall be deemed not to be a part of this Agreement.

Done this _____ day of _____, 2025.

THE CITY OF ORANGE BEACH, AL

(signature)

(printed name)

(position)



Paul O. Woodall, Jr.
D: 205.244.5276
F: 205.244.5476
pwoodall@joneswalker.com

December 2, 2025

VIA EMAIL

Ms. Jamie Logan
City of Orange Beach
P.O. Box 458
Orange Beach, AL 36561

Re: 2026 Engagement Letter

Dear Jamie:

I am pleased that you have selected our firm to act as counsel for the City of Orange Beach in performing legal services for the 2026 calendar year, primarily in the areas of real estate, public finance, economic incentives and other matters. This letter will describe the terms under which our firm will provide representation and advice with respect to such matters, as well as any other matters that you may ask us to work on.

Our fees for legal services are based upon the amount of time expended on your matter and the guideline hourly billing rates for the attorneys and legal assistants involved. All of our professionals are assigned hourly rates that are a function of their seniority and experience. These hourly rates are revised from time to time, but normally not more often than annually. My present hourly rate on this matter will be \$395 for the 2026 calendar year, which is a discounted rate from my "preferred rate".

I will be the attorney in our firm with the overall responsibility for the supervision of the services rendered. You can anticipate, from time to time, that some of the work may be delegated to other attorneys or legal assistance in our office who have special expertise or who may be able to perform your work more efficiently or economically.

We may advance or incur certain costs and expenses that will be charged to you. Such charges might include filing fees, long distance telephone charges, photocopying, electronic legal research, travel expenses and certain other out-of-pocket expenses. When the amounts involved are large, we may forward the invoice to you for direct payment. Otherwise, we will advance the expenses on your behalf and include the expenses on the next monthly statement.

If you have any questions about the terms of our engagement or the billing arrangements set forth above, please let me know. Otherwise, please sign and date this letter and return it to me by e-mail or regular mail. You should retain a copy of this letter for your records as well. Please feel free to bring to my attention any questions that you may have about a statement or the services performed. Thank you for your confidence you have expressed in our firm, and I look forward to continuing to work with you.

Sincerely,

Paul O. Woodall, Jr.

Paul O. Woodall, Jr.

POWjr/ds

Agreed to and accepted this _____ day of December 2025.

CITY OF ORANGE BEACH

By: _____
Print Name: _____
Its: _____



December __, 2025

Spencer E. Davis, Jr., Esq.
Spencer E. Davis, LLC
109 N.W. First Street
Summerdale, Alabama 36580

RE: APPOINTMENT AS ATTORNEY

Dear Spencer:

Pursuant to Chapter 2 of the *Code of Ordinances* for the City of Orange Beach, and as approved by Resolution No. 25-xxx of the City Council for the City of Orange Beach, adopted December 16, 2025, you are hereby appointed as the City Prosecutor for the Municipal Court.

Your appointment shall be effective January 1, 2026, through December 31, 2026. As compensation for your services, you shall be paid, in advance, a base monthly fee of \$4,600 per month, plus any actual out-of-pocket expenses. Additionally, you will be paid on an actual time spent basis at the rate of \$150.00 per hour for appeals to the Court of Criminal Appeals or the Supreme Court of Alabama.

If you are in agreement with these terms, please sign below and return to my office.

Sincerely,

Jamie P. Logan
City Attorney

Accepted: _____
Spencer E. Davis, Jr., Attorney

Date: _____

City Approval: _____
Tony Kennon, Mayor

Date: _____



**REGULAR CITY COUNCIL MEETING
DECEMBER 16, 2025**

Departments: City Clerk

Description of Topic: Resolution appointing members and reappointing existing members to the Legislative Review Committee.

Background/Description:

Action Options/Recommendation:

Source of Funding (if applicable):

ATTACHMENTS:

1. 12-16-25 25-xxx Appoint Legislative Review Committee

RESOLUTION NO. 25-xxx

**A RESOLUTION APPOINTING MEMBERS AND
REAPPOINTING EXISTING MEMBERS
TO THE LEGISLATIVE REVIEW COMMITTEE**

FINDINGS:

1. Each year, the Alabama Legislature and the United States Congress consider legislation that may affect the City of Orange Beach and other municipalities in the Gulf Coast region as well as the throughout the state.
2. It is important for the City to keep abreast of legislative developments and to implement a process that will insure the City's interests are protected and properly communicated to elected officials.
3. On January 15, 2013, the City Council adopted Resolution No. 13-010 forming a legislative review committee to promote an effective and efficient response to legislative action and ensure that the public interest in such matters is protected.
4. It is necessary to appoint new or replacement members to the committee and to reappoint other existing members.

NOW, THEREFORE, BE IT RESOLVED BY THE CITY COUNCIL OF THE CITY OF ORANGE BEACH, ALABAMA, AS FOLLOWS:

1. That the following persons are appointed to serve on the Legislative Review Committee for the City of Orange Beach:
Ford Handley – City Administrator/ Business/ Revenue
Renee Eberly – General Municipal/ Procurement
Fire Chief Jeff Smith – Fire/ EMS/ Public Safety
Interim Police Chief David “Trent” Johnson – Law Enforcement/ Public Safety
Chris Pappas – Engineering / Transportation / Infrastructure
Pam Davis – Judicial / Court
Griffin Powell – Planning / Zoning
Adam Roberson – Building / Flood Management / Planning / Zoning
Nicole Woerner – EMA / Coastal / Environmental
Phillip West – Coastal / Environmental
Marc Anderson – Administration / Special Projects

Council Appointee – Ginger Harrelson, Councilmember
Council Appointee – Robert Stuart, Councilmember
Council Appointee – Jeff Silvers, Councilmember
Legal Advisor – Jamie Logan
Paralegal – Ashley Tidwell
2. That the Committee is directed to monitor legislation affecting the City; to develop a process by which staff and others can review such legislation and provide feedback to Committee members; propose official city policy with respect to particular legislative items; coordinate action concerning same, including, but not limited to activating lobbyists, necessary staff, professional associations and their lobbying resources, and joint efforts with other cities;
3. That the Committee shall make periodic reports to the full Council;

4. That all previous resolutions or parts in conflict with this resolution, to the extent of such conflict, are hereby repealed; and
5. That this Resolution shall become effective immediately upon its adoption.

ADOPTED THIS 16th DAY OF DECEMBER, 2025.

Renee Eberly
City Clerk

C E R T I F I C A T E

I, Renee Eberly, City Clerk of the City of Orange Beach, Alabama, do hereby certify that the foregoing is a true and correct copy of Resolution No. 25-xxx, which was duly and legally adopted at a regular meeting of the City Council on December 16, 2025.

City Clerk



**REGULAR CITY COUNCIL MEETING
DECEMBER 16, 2025**

Departments: City Clerk

Description of Topic: Resolution authorizing the City of Orange Beach, Alabama, to levy taxes within its police jurisdiction for the year 2026.

Background/Description:

Action Options/Recommendation:

Source of Funding (if applicable):

ATTACHMENTS:

1. 12-16-25 25-xxx Authorize Levy Taxes Police Jurisdiction 2026

RESOLUTION NO. 25-xxx

**A RESOLUTION AUTHORIZING THE CITY OF ORANGE BEACH, ALABAMA
TO LEVY TAXES WITHIN ITS POLICE JURISDICTION FOR THE YEAR 2026**

FINDINGS:

1. On November 13, 2007, the City Council of the City of Orange Beach passed Ordinance No. 2007-1036 “Business License Code of the City of Orange Beach, Alabama for the Year 2008 and Each Subsequent Year”, codified under Section 50, Article III of the *Code of Ordinances for the City of Orange Beach*. This ordinance authorizes collection of privilege license taxes from persons engaged in business within the police jurisdiction of the City of Orange Beach.
2. Sec. 50-51, “Levy of Tax” of the *Code of Ordinances for the City of Orange Beach* references Ala. Code §11-51-90 (1975) et seq. and its authorization for municipalities who have passed an ordinance establishing such to collect privilege license taxes from persons engaged in business within the corporate limits of the city and its police jurisdiction.
3. The Alabama League of Municipalities strongly suggests that municipalities who operate under the authority of 11-51-91 compare annually the amount of revenue collected from the Police Jurisdiction with the cost of supervision to the area.
4. The Legal Department conducted an internal audit of the City’s 2024 Municipal Police Jurisdiction Report submitted to the Department of Examiners of Public Accounts and has determined that the revenue collected from the Police Jurisdiction is less than the cost of supervision of the area and as such the levy of tax therein continues to be appropriate.
5. Having reviewed the findings and advice of the City Attorney, the Council has determined that the police jurisdiction levy for the next license tax year shall be reaffirmed as is in the best interest of the City of Orange Beach, Alabama.

NOW, THEREFORE, BE IT RESOLVED BY THE CITY COUNCIL OF THE CITY OF ORANGE BEACH, ALABAMA, AS FOLLOWS:

1. That the City Council of the City of Orange Beach reaffirms the collection of privilege license taxes from persons engaged in business within its police jurisdiction for the year 2026; and
2. That this Resolution shall become effective immediately upon its adoption.

ADOPTED THIS 16th DAY OF DECEMBER, 2025.

Renee Eberly
City Clerk

C E R T I F I C A T E

I, Renee Eberly, City Clerk of the City of Orange Beach, Alabama, do hereby certify that the foregoing is a true and correct copy of Resolution No. 25-xxx, which was duly and legally adopted at a regular meeting of the City Council on December 16, 2025.

City Clerk



**REGULAR CITY COUNCIL MEETING
DECEMBER 16, 2025**

Departments: City Clerk

Description of Topic: Resolution authorizing execution of a professional services agreement with Chris Litton for various special services.

Background/Description:

Action Options/Recommendation:

Source of Funding (if applicable):

ATTACHMENTS:

1. 12-16-25 25-xxx Authorize Professional Services Agreement Chris Litton
2. 2025.11.26 Professional Services Agreement Chris Litton

RESOLUTION NO. 25-xxx

**A RESOLUTION AUTHORIZING EXECUTION OF A
PROFESSIONAL SERVICES AGREEMENT WITH
CHRIS LITTON FOR VARIOUS SPECIAL SERVICES**

FINDINGS:

1. The City of Orange Beach has reached an agreement (attached Exhibit A) with Chris Litton, an individual, whereby Chris Litton will provide special services including but not limited to audio production, firearms training and youth shooting sports organization and management, disaster recovery management, and veterans programs management.
2. After having reviewed the agreement, the City Council has determined that the provisions are in the best interest of the City of Orange Beach, Alabama.
3. The term of this agreement shall be for twelve (12) months commencing January 1, 2026, and ending December 31, 2026.

NOW, THEREFORE, BE IT RESOLVED BY THE CITY COUNCIL OF THE CITY OF ORANGE BEACH, ALABAMA, AS FOLLOWS:

1. That the Council authorizes the Mayor and City Clerk to execute and attest, respectively, the agreement in substantially the form and of substantially the content now before the Council between the City of Orange Beach and Chris Litton as an act for and on behalf of the City of Orange Beach subject to final approval by the City Attorney; and
2. That this Resolution shall become effective upon its adoption.

ADOPTED THIS 16th DAY OF DECEMBER, 2025.

Renee Eberly
City Clerk

C E R T I F I C A T E

I, Renee Eberly, City Clerk of the City of Orange Beach, Alabama, do hereby certify that the foregoing is a true and correct copy of Resolution No. 25-xxx, which was duly and legally adopted at a regular meeting of the City Council on December 16, 2025.

City Clerk

PROFESSIONAL SERVICES CONTRACT

This Agreement is made and entered into by and between the City of Orange Beach, a Class 8 Alabama municipal corporation (hereinafter the "City") and Chris Litton, an individual (hereinafter the "Contractor"), as follows:

1. Recitals.

WHEREAS, the City desires to engage Contractor to provide special services and specialized organizational services due to contractor's experience and certifications including, but not limited to audio production, firearms training and youth shooting sports organization and management, disaster recovery management, veterans programs management;

WHEREAS, the Contractor is skilled in providing such services and is available and willing to perform such services on the terms and conditions set forth in this Agreement;

NOW, THEREFORE, for and in consideration of the mutual covenants and agreements hereinafter set forth to be kept and performed by the other, and other good and valuable consideration, the receipt and sufficiency of all of which are hereby acknowledged, the parties to hereby covenant and agree as follows:

2. Consulting Services to be Performed.

a) Contractor will perform such services with regard to the City's special events, performances, shooting and firearm classes, possibly emergency management skills and general support of city activities as needed, based on many years of experience and institutional knowledge.

3. Compensation.

a) As full and total compensation for the services to be provided pursuant to this Agreement, Contractor shall be paid \$40/hour, plus pre-approved expenses incurred as part of Contractor's performance of this contract, in accordance with City policies.

b) Contractor agrees to abide by the City's established policies, and agrees that any travel and expenses must be approved in advance by the City.

c) Contractor shall be paid per invoice following city activities and events, upon the City's receipt of a properly documented invoice for specialized services performed. All estimated hours and expenses shall be pre-approved in planning for city events and activities.

4. Term.

The term of this Agreement is twelve (12) months commencing January 1, 2026, and ending December 31, 2026.

5. Independent Contractor.

a) Notwithstanding any of the provisions of this Agreement, it is agreed that the City has no financial interest in the business of Contractor and shall not be liable for any debts or obligations incurred by Contractor, nor shall City be deemed or construed to be a partner, joint venturer or otherwise interested in the assets of Contractor, or in the sums earned or derived by Contractor.

b) Contractor, in the performance of its operations and obligations hereunder, shall not be deemed to be an agent of City but shall be deemed to be an independent Contractor in every respect and shall take all steps at its own expense as City may from time to time request to indicate that it is an independent Contractor. City does not, and will not, assume any responsibility for the means by which or the manner in which the services by Contractor provided for herein are performed but, on the contrary, Contractor shall be wholly responsible therefor.

6. Insurance.

- a) For the term of this Agreement, the Contractor shall acquire and maintain in full force and affect the policy of insurance evidenced by the certificate of insurance attached hereto, with the City being named as an additional insured.
- b) Said certificate shall require that said insurance coverage will not be altered or terminated unless City shall be given written notice of such alteration or termination delivered to City not less than thirty (30) days before the effective date of such alteration or termination.

7. Assignment.

Contractor acknowledges that its identity and peculiar capacity to provide the services described hereinabove constitute a material consideration for City's having entered into this Agreement. Therefore, Contractor shall not transfer or assign this Agreement or any of the rights or privileges granted herein without the prior written consent of City; which consent shall be granted or denied solely at City's discretion.

8. Compliance with Law.

Contractor hereby agrees to comply strictly with all the laws of the State of Alabama and of the United States, and the laws and ordinances of any other jurisdiction in which contractor may perform any work pursuant to this Agreement. Contractor further agrees to comply with all rules, regulations, policies, and City ordinances that apply to sporting or other activities at City properties and facilities.

9. Termination.

This Agreement may be terminated by either party for any reason upon thirty (30) days notice of the intent to terminate. Upon termination, Contractor shall be paid *pro rata* for all services actually rendered up to the effective date of termination. This Agreement may be terminated immediately by the City upon failure of the required background check or drug testing, as set out in paragraph 16, below.

10. Final Agreement.

This Agreement is the final expression of the Agreement between the parties, and the complete and exclusive statement of the terms agreed upon, and shall supersede all prior negotiations, understandings or agreements. There are no representations, warranties, or stipulations, either oral or written, not contained herein.

11. Modifications.

Any alterations, variations, modifications or waivers of the provisions of this Agreement shall only be valid when they have been reduced to writing, approved by the City Council, and signed by the duly authorized representatives of both parties.

12. Severability.

The provisions of this Agreement shall be deemed severable. If any part of this Agreement is rendered void, invalid or unenforceable, such rendering shall not affect the enforceability of the remainder of this Agreement unless the part or parts which are void, invalid or otherwise unenforceable shall substantially impair the value of the entire Agreement with respect to either party.

13. Law Governing.

This Agreement shall be governed by the laws of the State of Alabama, and the appropriate venue for any actions arising out of this Agreement would be Baldwin County, Alabama.

14. Permits, etc.

Contractor shall obtain, at its own expense, all necessary licenses, permits, insurance, authorizations and assurances necessary in order to abide by the terms of this Agreement.

15. Background Check and Drug Testing.

Contractor consents to the City of Orange Beach to conduct a background check and drug testing in order for Contractor to provide coaching services as set out herein. Contractor shall provide all required information to the City in order to conduct the background check and drug testing including, but not limited to, full name (maiden name), physical address, date of birth, social security number, driver's license state and number.

16. Notices.

All notices of cancellation, requests, demands or other communications shall be in writing and duly delivered to the addresses appearing below:

City of Orange Beach
City Clerk
Post Office Box 458
Orange Beach, AL 36561

Copy to:
City Attorney
P.O. Box 458
Orange Beach, AL 36561

And to Contractor:

Chris Litton
P.O. Box 441
Gulf Shores, AL 36542

IN WITNESS WHEREOF, we have hereunto set our hands and seal on this the ____ day of _____, 2025.

CITY OF ORANGE BEACH

By: _____
Tony Kennon
Mayor

ATTEST:

Renee Eberly, City Clerk

Chris Litton, an Individual

[ACKNOWLEDGEMENTS ON FOLLOWING PAGE]

STATE OF ALABAMA
COUNTY OF BALDWIN

I, the undersigned Notary Public in and for said County in said State, hereby certify that Tony Kennon and Renee Eberly, whose names as Mayor and City Clerk, respectively, of the City of Orange Beach, a municipal corporation, are signed to the foregoing agreement, and who are known to me, acknowledge before me on this day, that, being informed of the contents of the above and foregoing, they, as such officers and with full authority, executed the same voluntarily for and as the act of said municipal corporation on the day the same bears date.

Given under my hand and seal this the _____ day of _____, 2025.

(SEAL)

Notary Public
State of Alabama
My Commission Expires: _____

STATE OF ALABAMA
COUNTY OF BALDWIN

I, the undersigned Notary Public, in and for said County in said State, hereby certify that Chris Litton, an Individual, whose name is signed to the foregoing agreement, and who is known to me, acknowledged before me this day that, being informed of the contents of the above and foregoing agreement, he executed the same voluntarily on the day the same bears date.

Given under my hand and seal this the _____ day of _____, 2025.

(SEAL)

Notary Public
State of Alabama
My Commission Expires: _____



**REGULAR CITY COUNCIL MEETING
DECEMBER 16, 2025**

Departments: City Clerk

Description of Topic: Resolution extending the entertainment district at SanRoc Cay Marina / Perdido Beach Resort.

Background/Description:

Action Options/Recommendation:

Source of Funding (if applicable):

ATTACHMENTS:

1. 12-16-25 25-xxx Extend Entertainment District SanRoc Cay Marina Perdido Beach Resort

RESOLUTION NO. 25-xxx

**A RESOLUTION EXTENDING THE ENTERTAINMENT DISTRICT
AT SANROC CAY MARINA / PERDIDO BEACH RESORT**

FINDINGS:

1. On July 10, 2012, the City Council, pursuant to Alabama Code §28-3A-17.1, adopted Resolution No. 12-089 designating SanRoc Cay Marina / Perdido Beach Resort as an Entertainment District as allowed by Ordinance No. 2012-1150.
2. Extensions are issued annually by City Council with the current extension authorized by Resolution No. 24-220 expiring on December 31, 2025.
3. City Council deems it appropriate to extend the district designation for one year.

NOW, THEREFORE, BE IT RESOLVED BY THE CITY COUNCIL OF THE CITY OF ORANGE BEACH, ALABAMA, AS FOLLOWS:

1. That the Entertainment District at SanRoc Cay Marina / Perdido Beach Resort is hereby extended to December 31, 2026;
2. That a copy of this resolution shall be sent to the Alabama Beverage Control Board; and
3. That this Resolution shall become effective upon its adoption.

ADOPTED THIS 16th DAY OF DECEMBER, 2025.

Renee Eberly
City Clerk

C E R T I F I C A T E

I, Renee Eberly, City Clerk of the City of Orange Beach, Alabama, do hereby certify that the foregoing is a true and correct copy of Resolution No. 25-xxx, which was duly and legally adopted at a regular meeting of the City Council on December 16, 2025.

City Clerk



**REGULAR CITY COUNCIL MEETING
DECEMBER 16, 2025**

Departments: City Clerk

Description of Topic: Resolution extending the entertainment district at The Wharf.

Background/Description:

Action Options/Recommendation:

Source of Funding (if applicable):

ATTACHMENTS:

1. 12-16-25 25-xxx Extend Entertainment District Wharf

RESOLUTION NO. 25-xxx

**A RESOLUTION EXTENDING THE ENTERTAINMENT DISTRICT
AT THE WHARF**

FINDINGS:

1. On July 5, 2012, the City Council, pursuant to Alabama Code §28-3A-17.1., adopted Resolution No. 12-088 designating The Wharf as an Entertainment District as allowed by Ordinance No. 2012-1150.
2. Extensions are issued annually by City Council with the current extension authorized by Resolution No. 24-221 expiring on December 31, 2025.
3. City Council deems it appropriate to extend the district designation for one year.

NOW, THEREFORE, BE IT RESOLVED BY THE CITY COUNCIL OF THE CITY OF ORANGE BEACH, ALABAMA, AS FOLLOWS:

1. That the Entertainment District at The Wharf is hereby extended to December 31, 2026;
2. That a copy of this resolution shall be sent to the Alabama Beverage Control Board; and
3. That this Resolution shall become effective upon its adoption.

ADOPTED THIS 16th DAY OF DECEMBER, 2025.

Renee Eberly
City Clerk

C E R T I F I C A T E

I, Renee Eberly, City Clerk of the City of Orange Beach, Alabama, do hereby certify that the foregoing is a true and correct copy of Resolution No. 25-xxx, which was duly and legally adopted at a regular meeting of the City Council on December 16, 2025.

City Clerk



**REGULAR CITY COUNCIL MEETING
DECEMBER 16, 2025**

Departments: City Clerk

Description of Topic: Resolution authorizing the execution of a professional services agreement with McCollough Architecture, Inc., for architectural services.

Background/Description:

Action Options/Recommendation:

Source of Funding (if applicable):

ATTACHMENTS:

1. 12-16-25 25-xxx Authorize Professional Services Agreement McCollough Architecture
2. 2025.11.26 Professional Services Agreement McCollough Architecture

RESOLUTION NO. 25-xxx

**A RESOLUTION AUTHORIZING THE EXECUTION OF A
PROFESSIONAL SERVICES AGREEMENT WITH
MCCOLLOUGH ARCHITECTURE, INC., FOR
ARCHITECTURAL SERVICES**

FINDINGS:

1. The professional services agreement with McCollough Architecture, Inc., adopted by Orange Beach City Council through Resolution No. 23-155 adopted August 15, 2023, has expired.
2. The City of Orange Beach and McCollough Architecture, Inc., have reached an agreement (attached Exhibit A) whereby McCollough Architecture, Inc., will provide architectural services for the City of Orange Beach.
3. The Agreement authorizes work to be assigned by one or more task orders approved from time to time by the City Council.
4. After having reviewed the agreement, the City Council has determined that the provisions are in the best interest of the City of Orange Beach, Alabama.
5. The term of this agreement shall be for twenty-four (24) months commencing on January 1, 2026, and ending December 31, 2027.

NOW, THEREFORE, BE IT RESOLVED BY THE CITY COUNCIL OF THE CITY OF ORANGE BEACH, ALABAMA, AS FOLLOWS:

1. That the Mayor is hereby authorized to execute the agreement in substantially the form and of substantially the content now before the Council between the City of Orange Beach and McCollough Architecture, Inc., as an act for and on behalf of the City of Orange Beach subject to final approval by the City Attorney; and
2. That this Resolution shall become effective immediately upon its adoption.

ADOPTED THIS 16th DAY OF DECEMBER, 2025.

Renee Eberly
City Clerk

C E R T I F I C A T E

I, Renee Eberly, City Clerk of the City of Orange Beach, Alabama, do hereby certify that the foregoing is a true and correct copy of Resolution No. 25-xxx, which was duly and legally adopted at a regular meeting of the City Council on December 16, 2025.

City Clerk

PROFESSIONAL SERVICES CONTRACT

THIS PROFESSIONAL SERVICES CONTRACT (hereinafter “Agreement”) is made and entered into by and between the City of Orange Beach, an Alabama Municipal Corporation (hereinafter “City”), and McCollough Architecture, Inc. (hereinafter “Contractor”), as follows:

WHEREAS, Contractor is engaged in the business of providing Architectural services;

WHEREAS, City desires to engage Contractor to provide said services upon the following terms and conditions;

NOW THEREFORE,

WITNESSETH:

City and Contractor, for and in consideration of the mutual covenants and agreements hereinafter set forth to be kept and performed by the other, and other good and valuable consideration, the receipt and sufficiency of all of which are hereby acknowledged, do hereby covenant and agree as follows:

I. SERVICES TO BE PERFORMED

Contractor agrees to perform Architectural Services, and to represent the City as requested as their Architectural Consultant on a variety of assigned project. Each project will be assigned to Contractor in the form of a written Task Order describing the scope of work. A copy of this Agreement shall be attached to each Task Order.

Contractor agrees to perform services that may include, but not be limited to, programming, planning, design, construction documents, construction administration, architectural consultation to the City as requested, and other services as requested.

Civil, Environmental, and Geotechnical engineering required for projects associated with the Contractor’s work shall be provided by others. The Contractor shall work with the City’s engineer(s) assigned to the project.

II. COMPENSATION

Fees for work completed and reimbursable expenses will be invoiced to the City on a monthly basis, based on the following hourly rate schedule. It is anticipated that hourly fees will apply to conceptual and programming work in order to establish definitive scope of work for a specific project (Task Order). Once a project scope is identified, it is anticipated that a lump-sum fee will be established based on a percentage of the estimated cost of construction (see Alabama Building Commission Fee Schedule):

<u>Classification</u>	<u>Hourly Billing Rate</u>
Architect	\$ 150.00
CAD Operator (Draftsman)	\$ 85.00
Clerical	\$ 30.00
Engineering (Structural; Mechanical; Plumbing; Electrical)	Cost plus 15%
Interior Designer	\$ 100.00
Landscape Architect	\$ 125.00

III. TERM OF AGREEMENT

The term of this Agreement is twenty-four (24) months commencing January 1, 2026, and ending December 31, 2027, unless terminated earlier in accordance with the termination provisions of this Agreement. This Agreement may be renewed by resolution adopted by the City Council.

IV. GENERAL PROVISIONS

- A. Contractor agrees to permit at all reasonable times and places an audit of its books and records by City's duly authorized representatives.
- B. Notwithstanding any of the provisions of this Agreement, it is agreed that City has no financial interest in the business of Contractor and shall not be liable for any debts or obligations incurred by Contractor, nor shall City be deemed or construed to be a partner, joint venture or otherwise interested in the assets of Contractor, or in the sums earned or derived by Contractor, nor shall Contractor at any time or times use the name or credit of City in purchasing or attempting to purchase any car, equipment, supplies or other thing or things whatsoever.
- C. Contractor shall act as a representative of the City, under the direct supervision of the City. Contractor shall have no authority to obligate the City in any way whatsoever. In the performance of his duties, the Contractor shall be deemed an independent contractor.
- D. Contractor acknowledges that its identity and peculiar capacity to provide the services described hereinabove constitute a material consideration for City's having entered into this Agreement. Therefore, Contractor shall not transfer or assign this Agreement or any of the rights or privileges granted herein without the prior written consent of City; which such consent shall be granted or denied solely at City's discretion.
- E. Contractor hereby agrees to comply strictly with all ordinances of the City of Orange Beach, Alabama, and the laws of the State of Alabama and of the United States while performing its obligations under the terms of this Agreement.
- F. Contractor agrees that upon the violation of any of the covenants and agreements herein contained, on account of any act or omission or commission of Contractor, City may, at its option, terminate and cancel this Agreement.
- G. Contractor agrees that it will comply with Title 6 of the Civil Rights Act of 1964 which provides that no person will be excluded from participation in, or be denied benefits of, or otherwise be subjected to discrimination on the grounds of race, sex, color, national origin, or disability, in connection with federally funded programs.
- H. City may terminate this Agreement with or without cause at any time by giving written notice to Contractor of such termination (herein called a "Notice of Termination"), specifying the effective date thereof not less than thirty (30) calendar days before the effective date of the termination. Contractor shall have the right to terminate this Agreement by giving City written notice and remaining in service for a sufficient time to allow City to seek a suitable replacement. Should Contractor be terminated pursuant to the terms of this subpart, then this Agreement shall terminate on the last day of Contractor's current month of employment and City shall not be liable for any compensation beyond that date.
- I. Contractor agrees to indemnify and hold the City, its elected officials, officers, agents, and employees whole and harmless from all costs, liabilities and claims for damages of any kind arising in any way out of the negligent acts, errors or omissions of the contractor in performance

of this Agreement and/or the activities of the Contractor, its principals, directors, agents, servants and employees in the performance of this Agreement, for which the City is alleged to be liable. In the event the City, through no fault of its own, is made a party to any lawsuit or legal proceeding arising from Contractor's activities under this Agreement, Contractor agrees to indemnify and hold the City harmless from all costs, including attorneys' fees and expenses, associated with same. This indemnification extends only to third party claims and actions filed against the City as a result of any negligent actions by the Contractor under this Agreement. This duty shall survive the termination of this contract.

- J. All notices of cancellation, requests, demands, or other communications shall be in writing and duly delivered to the following address for City at:

Renee Eberly, City Clerk
P.O. Box 458
Orange Beach, Alabama 36561

Copy to: City Attorney

And to Contractor at:

McCollough Architecture
4790 Main Street Suite F-209
Orange Beach, Alabama 36561

- K. This Agreement is the final expression of the agreement between the parties, and the complete and exclusive statement of the terms agreed upon, and shall supersede all prior negotiations, understandings, or agreements. There are no representations, warranties, or stipulations, either oral or written, not contained herein.
- L. Any alterations, variations, modifications, or waivers of the provisions of this Agreement shall only be valid when they have been reduced to writing and signed by authorized representatives of the party against whom enforcement is sought.
- M. The provisions of this Agreement shall be deemed severable. If any part of this Agreement is rendered void, invalid or unenforceable, such rendering shall not affect the enforceability of the remainder of this Agreement unless the part or parts which are void, invalid or otherwise unenforceable shall substantially impair the value of the entire agreement with respect to any party.
- N. This Agreement shall be governed by the laws of the State of Alabama, and the appropriate venue for any actions arising out of this Agreement shall be Baldwin County, Alabama.
- O. Contractor shall obtain, at its own expense, all necessary licenses, permits, insurance, authorization and assurances necessary in order to abide by the terms of this Agreement.

V. INSURANCE

For the term of this Agreement, the Contractor shall acquire and maintain in full force and effect the following liability and comprehensive insurance issued by a company licensed and qualified to do business in the State of Alabama, which such insurance shall name the City of Orange Beach as an additional insured, and shall attach to this contract, as proof thereof, a certificate of insurance issued by an agent licensed and qualified to do business in the State of Alabama:

Worker's Compensation – as required by State of Alabama law

General Liability Insurance – public liability including premises, products, complete operations and automobile comprehensive and liability, including owned, non-owned, and hired vehicles.

Either:

- (1) Bodily injury liability
 - \$250,000 each person
 - \$500,000 each occurrence
- Property damage liability
 - \$100,000 each occurrence

Or,

- (2) Bodily injury and property damage combined
 - \$500,000 per occurrence

Professional Errors and Omissions – coverage limits of \$3,000,000 each claim and policy aggregate, an extended discovery period to apply for at least two (2) years after work is accepted by the City of Orange Beach, and a deductible not to exceed \$10,000 for which the Contractor will remain solely responsible.

If the certificate of insurance referenced in this Agreement does not evidence insurance of owned vehicles, said certificate and this sentence shall evidence the Contractor's covenant that it does not own any vehicles and that it will not purchase or obtain any vehicles during the term of this Agreement.

Said certificate shall require that said insurance will not be altered or terminated unless City shall be given written notice of such alteration or termination delivered to City not less than thirty (30) days before the effective date of such alteration or termination.

VI. CONFIDENTIALITY

Contractor (including its employees, agents, subcontractors) acknowledges that all confidential business and personal information ("Protected Information") that it may obtain while performing services for the City, is deemed confidential and proprietary to the City. During Contractor's tenure with the City, Contractor agrees to use Protected Information only and strictly as required to perform its services on behalf of the City. Contractor will not disclose Protected Information to any person or entity without the prior written consent of the City and the written agreement of any third party. Contractor agrees to refer any request for public information or records to the City Clerk, who is the custodian of records for the City and is responsible for the disclosure of public records in accordance with the public records laws of the state. Contractor agrees that it will not duplicate or incorporate Protected Information into its own records or databases and that after the conclusion of its services to the City all Protected Information in the Contractor's possession will be turned over to the City. Contractor agrees not to disclose, use, transfer, or transmit the information to any person or entity for any purpose whatsoever. This includes records, passwords, access codes, manuals, statistics, software, audio/video recordings, or storage disks of any kind containing Protected Information.

IN WITNESS WHEREOF, we have hereunto set our hands and seals on this the _____ day of _____, 20____.

CITY OF ORANGE BEACH, A Municipal Corporation

By: _____
Mayor Tony Kennon

ATTEST:

Renee Eberly, City Clerk

CONTRACTOR:

McCollough Architecture, Inc.

By: _____
Sted McCollough

Its: Principal

STATE OF ALABAMA
COUNTY OF BALDWIN

I, the undersigned Notary Public in and for said County in said State, hereby certify that Tony Kennon and Renee Eberly, whose names as Mayor and City Clerk, respectively, of the City of Orange Beach, a Municipal Corporation, are signed to the foregoing agreement, and who are known to me, acknowledged before me on this day, that, being informed of the contents of the above and foregoing, they, as such officers and with full authority, executed the same voluntarily for and as the act of said municipal corporation on the day the same bears date.

Given under my hand and seal this the _____ day of _____, 2025.

(SEAL)

Notary Public
State of Alabama At-Large
My Commission Expires: _____

STATE OF ALABAMA
COUNTY OF _____

I, the undersigned Notary Public, in and for said county in said state, hereby certify that Sted McCollough, whose name as Principal of McCollough Architecture, Inc., an Alabama corporation, is signed to the foregoing agreement, and who is known to me, acknowledged before me on this day that, being informed of the contents of the above and foregoing agreement, he as such officer and with full authority, executed the same voluntarily for and as the act of said corporation on the day the same bears date.

Given under my hand and seal this the _____ day of _____, 2025.

(SEAL)

Notary Public
State of Alabama At-Large
My Commission Expires: _____



**REGULAR CITY COUNCIL MEETING
DECEMBER 16, 2025**

Departments: City Clerk

Description of Topic: Resolution authorizing execution of a performance contract with Baldwin County Economic Development Alliance, Inc.

Background/Description:

Action Options/Recommendation:

Source of Funding (if applicable): Budgeted, Admin Aid to Other Governments, \$12,500 for FY2026

ATTACHMENTS:

1. 12-16-25 25-xxx Authorize Performance Contract Baldwin County Economic Development Alliance BCEDA
2. 2025.11.26 Performance Contract Economic Development Alliance BCEDA

RESOLUTION NO. 25-xxx

**A RESOLUTION AUTHORIZING EXECUTION OF A
PERFORMANCE CONTRACT WITH
BALDWIN COUNTY ECONOMIC DEVELOPMENT ALLIANCE, INC.**

FINDINGS:

1. The City Council for the City of Orange Beach, Alabama, has reviewed the performance of Baldwin County Economic Development Alliance, Inc., as the regional development agency.
2. The City Council desires to support the goals and initiatives of the Baldwin Economic Development Alliance, Inc.
3. The term of this agreement shall be for twelve (12) months commencing January 1, 2026, and ending December 31, 2026.

NOW, THEREFORE, BE IT RESOLVED BY THE CITY COUNCIL OF THE CITY OF ORANGE BEACH, ALABAMA, AS FOLLOWS:

1. That the Council authorizes the Mayor and City Clerk to execute and attest, respectively, the agreement (attached Exhibit A) in substantially the form and of substantially the content now before the Council between the City of Orange Beach and Baldwin County Economic Development Alliance, Inc., as an act for and on behalf of the City of Orange Beach subject to final approval by the City Attorney; and
2. That this Resolution shall become effective immediately upon its adoption.

ADOPTED THIS 16th DAY OF DECEMBER, 2025.

Renee Eberly
City Clerk

C E R T I F I C A T E

I, Renee Eberly, City Clerk of the City of Orange Beach, Alabama, do hereby certify that the foregoing is a true and correct copy of Resolution No. 25-xxx, which was duly and legally adopted at a regular meeting of the City Council on December 16, 2025.

City Clerk

STATE OF ALABAMA

COUNTY OF BALDWIN

PERFORMANCE CONTRACT

THIS PERFORMANCE CONTRACT (hereinafter “Agreement”) is made and entered into by and between the City of Orange Beach, an Alabama Municipal Corporation (hereinafter “City”) and the Baldwin County Economic Development Alliance, Inc., a 501(c)(6) non-profit corporation (hereinafter “Alliance”).

WHEREAS, the City has determined that the welfare of the City’s citizens requires a healthy, diverse economy, new capital investment, and job opportunities;

WHEREAS, the Alliance serves as the regional economic development agency covering Baldwin County and all municipalities within, with the goal of creating jobs, recruiting capital investment, and retaining existing business;

WHEREAS, the Alliance works to promote and market Baldwin County and specifically utilizes the relationship with the City of Orange Beach staff and officials to recruit new companies into the region and to assist existing business with expansion needs; and

NOW THEREFORE,

WITNESSETH:

The City expresses its support for the goals and initiatives of the Alliance, and the City and Alliance, for and in consideration of the mutual covenants and agreements hereinafter set forth to be kept and performed by the other, and other good and valuable consideration, the receipt and sufficiency of all of which are hereby acknowledged, do hereby covenant and agree as follows:

1. The term of this agreement shall begin upon the execution hereof and remain in full force for the calendar year of 2026.
2. The City agrees to invest \$12,500 in the Alliance for one year.
3. In response to the investment, the Alliance shall:
 - a. Provide and administer economic development services benefitting the City;
 - b. Endeavor to attract and promote new and expanding business prospects within Baldwin County, Alabama;
 - c. Create jobs and employment opportunities for citizens; and
 - d. Provided research and data as needed while marketing the region to prospects.
4. Notwithstanding any of the provisions of this contract, it is understood and agreed that the City has no financial interest in the business of the Alliance and shall not be liable for any debts or obligations incurred by the Alliance, nor shall the City be deemed or construed to be a partner, joint venture, or otherwise interested in the assets of the Alliance, or profits earned or derived by the Alliance, nor shall the Alliance at any time or times use the name or credit of the City in purchasing, or attempting to purchase equipment, supplies, or other things whatsoever.

5. The Alliance, in the performance of its duties, responsibilities, and obligations hereunder, shall not be deemed to be an agent of the City, but shall take all steps at its own expense, as the City may from time to time request, to indicate and assure that it is an independent contractor. The City does not, and will not, assume any responsibility for the means which, or manner in which, services by the Alliance, provided for herein, are performed, but on the contrary, the Alliance shall be wholly responsible therefore.
6. The Alliance shall not transfer or assign this Contract or any of the rights or privileges granted herein without the prior written consent of the City, the Alliance shall comply strictly with all the laws of Baldwin County, Alabama, the State of Alabama, the United States of America, and all the rules and regulations of all applicable agencies thereof.

IN WITNESS WHEREOF, we have hereunto set our hands and seals on this the ____ day of _____, 2025.

CITY OF ORANGE BEACH, A Municipal Corporation

By: _____
Anthony T. Kennon, Mayor

ATTEST:

Renee Eberly, City Clerk

BALDWIN COUNTY ECONOMIC DEVELOPMENT
ALLIANCE, INC.

By: _____
Lee Lawson, President and CEO



**REGULAR CITY COUNCIL MEETING
DECEMBER 16, 2025**

Departments: City Clerk

Description of Topic: Resolution appropriating funds to the Gulf Shores Airport Authority in an amount not to exceed \$75,000 for FY2026.

Background/Description:

Action Options/Recommendation:

Source of Funding (if applicable): Budgeted, Admin Aid to Other Governments, \$75,000 for FY2026

ATTACHMENTS:

1. 12-16-25 25-xxx Appropriate Funds JKA Airport Authority FY2026

RESOLUTION NO. 25-xxx

**A RESOLUTION APPROPRIATING FUNDS TO THE
GULF SHORES AIRPORT AUTHORITY
IN AN AMOUNT NOT TO EXCEED \$75,000 FOR FY2026**

FINDINGS:

1. On May 3, 2016, the Orange Beach City Council adopted Resolution No. 16-082 authorizing the Mayor to execute a performance contract with the Airport Authority of the City of Gulf Shores.
2. On February 21, 2017, Orange Beach City Council adopted Resolution No. 17-055 amending the performance contract to state that, “the City shall make an annual lump sum payment in the amount of Thirty-Five Thousand Dollars (\$35,000.00), or such other amount as may from time to time be approved by the Orange Beach City Council, on or before March 1st of every year. All such funds shall be maintained by the Authority and designated “Orange Beach Marketing Fund,” and shall be used solely for the purposes set forth in this contract.”
3. The Orange Beach City Council supports the expansion of services at the Jack Edwards National Airport, and would like to increase the contribution for Fiscal Year 2026 from \$35,000 to \$75,000.
4. City Council has determined that financially supporting the expansion of services at the Jack Edwards National Airport serves a public purpose for the City of Orange Beach.

NOW, THEREFORE, BE IT RESOLVED BY THE CITY COUNCIL OF THE CITY OF ORANGE BEACH, ALABAMA, AS FOLLOWS:

1. That Council appropriates a sum not to exceed Seventy-Five Thousand Dollars (\$75,000.00) to the Gulf Shores Airport Authority for FY2026 to be designated “Orange Beach Marketing Fund” to be used solely for the purposes set forth in the performance contract authorized through Resolutions No. 16-082 and 17-055; and
2. That this Resolution shall become effective immediately upon its adoption.

ADOPTED THIS 16th DAY OF DECEMBER, 2025.

Renee Eberly
City Clerk

C E R T I F I C A T E

I, Renee Eberly, City Clerk of the City of Orange Beach, Alabama, do hereby certify that the foregoing is a true and correct copy of Resolution No. 25-xxx, which was duly and legally adopted at a regular meeting of the City Council on December 16, 2025.

City Clerk



**REGULAR CITY COUNCIL MEETING
DECEMBER 16, 2025**

Departments: City Clerk

Description of Topic: Resolution authorizing execution of a professional services agreement with Socialize Your Bizness, Inc., for social media consulting and marketing services.

Background/Description: Contract renewal

Action Options/Recommendation:

Source of Funding (if applicable): Budgeted, Admin Professional Services, \$21,600 for FY2026

ATTACHMENTS:

1. 12-16-25 25-xxx Authorize Professional Services Agreement Socialize Your Bizness Social Media
2. 2025.11.26 Professional Services Agreement Socialize Your Bizness Social Media

RESOLUTION NO. 25-xxx

**A RESOLUTION AUTHORIZING EXECUTION OF A
PROFESSIONAL SERVICES AGREEMENT WITH
SOCIALIZE YOUR BIZNESS, INC., FOR
SOCIAL MEDIA CONSULTING AND MARKETING SERVICES**

FINDINGS:

1. The City Council for the City of Orange Beach, Alabama, has reviewed the performance of Socialize Your Bizness, Inc., for social media consulting and marketing services.
2. After having reviewed the agreement (attached Exhibit A), the City Council has determined that the provisions are in the best interest of the City of Orange Beach, Alabama.
3. The term of this agreement shall be for twelve (12) months commencing January 1, 2026, and ending December 31, 2026.

NOW, THEREFORE, BE IT RESOLVED BY THE CITY COUNCIL OF THE CITY OF ORANGE BEACH, ALABAMA, AS FOLLOWS:

1. That the Council authorizes the Mayor and City Clerk to execute and attest, respectively, the agreement in substantially the form and of substantially the content now before the Council between the City of Orange Beach and Socialize Your Bizness, Inc., as an act for and on behalf of the City of Orange Beach subject to final approval by the City Attorney; and
2. That this Resolution shall become effective upon its adoption.

ADOPTED THIS 16th DAY OF DECEMBER, 2025.

Renee Eberly
City Clerk

C E R T I F I C A T E

I, Renee Eberly, City Clerk of the City of Orange Beach, Alabama, do hereby certify that the foregoing is a true and correct copy of Resolution No. 25-xxx, which was duly and legally adopted at a regular meeting of the City Council on December 16, 2025.

City Clerk

PROFESSIONAL SERVICES CONTRACT

This Agreement is made and entered into by and between the City of Orange Beach, an Alabama municipal corporation (the “City”) and Socialize Your Bizness, Inc., an Alabama corporation (sometimes hereinafter “Contractor”), as follows:

1. Recitals.

WHEREAS, Contractor is a consulting firm that provides social media strategies for digital marketing;

WHEREAS, the City desires to engage Contractor to provide said services upon the following terms and conditions;

NOW, THEREFORE, for and in consideration of the mutual covenants and agreements hereinafter set forth to be kept and performed by the other, and other good and valuable consideration, the receipt and sufficiency of all of which are hereby acknowledged, the parties do hereby covenant and agree as follows:

2. Scope of Services.

Contractor will provide 20-30 hours per month for the following services:

- (a) General Social Media strategy and marketing consulting;
- (b) Social Media updates or creation, management and daily responsibility;
- (c) Facebook and Twitter pages;
- (d) Development and execution of a social content strategy. Any special events or product announcements will be incorporated per City request;
- (e) Management of posting, posting at least 1-2 times per day;
- (f) Cross promotion with industry related community projects, businesses, centers, activities, events, etc., upon request;
- (g) Responding and engaging with fans and followers to build relationships;
- (h) Reputation management, including approved responses to unfavorable community reviews;
- (i) Content writing as needed in the way of press releases, community flyers, notices and announcements;
- (j) Two (2) live videos per month;
- (k) Attendance at select City events, as needed.

3. Compensation.

Contract will be paid on a monthly retainer of \$1,800.00 for the services provided pursuant to this Agreement. Payments will be made upon receipt of an invoice from Contractor detailing work performed and hours worked.

4. Term.

The term of this Agreement is twelve (12) months commencing January 1, 2026, and ending December 31, 2026, unless terminated earlier in accordance with paragraph 9. This Agreement may be renewed by resolution adopted the City Council.

5. Independent Contractor.

Notwithstanding any of the provisions of this Agreement, it is agreed that City has no financial interest in the business of Contractor and shall not be liable for any debts or obligations incurred by Contractor, nor shall City be deemed or construed to be a partner, joint venturer or otherwise

interested in the assets of Contractor, or in the sums earned or derived by Contractor, nor shall Contractor at any time or times use the name or credit of City in purchasing or attempting to purchase any car, equipment, supplies or other thing or things whatsoever.

Contractor, in the performance of its operations and obligations hereunder, shall not be deemed to be an agent of City but shall be deemed to be an independent Contractor in every respect and shall take all steps at its own expense, as City may from time to time request, to indicate that it is an independent Contractor. City does not and will not assume any responsibility for the means by which or the manner in which the services by Contractor provided for herein are performed, but on the contrary, Contractor shall be wholly responsible therefor.

6. Assignment.

Contractor acknowledges that its identity and peculiar capacity to provide the services described hereinabove constitute a material consideration for City's having entered into this Agreement. Therefore, Contractor shall not transfer or assign this Agreement or any of the rights or privileges granted herein without the prior written consent of City; which such consent shall be granted or denied solely at City's discretion.

7. Indemnity.

Contractor agrees to indemnify and hold the City, its elected and appointed officials, officers, agents, and employees, harmless from all costs, liabilities and claims for damages of any kind (including interest and attorneys' fees) arising in any way out of the performance of this Agreement and/or the activities of Contractor, its principals, directors, agents, servants and employees in the performance of this Agreement, for which the City is alleged to be liable. This section is not as to third parties or to anyone a waiver of any defense of immunity or statutory damages cap otherwise available to Contractor or City and these defenses and matters may be raised in the City's behalf in any action or proceeding arising from this Agreement.

8. Compliance with Law.

Contractor hereby agrees to comply strictly with all the laws of the State of Alabama and of the United States, and the laws and ordinances of any other jurisdiction in which contractor may perform any work pursuant to this Agreement.

9. Termination.

This Agreement may be terminated by either party for any reason upon thirty (30) days notice of the intent to terminate. Upon termination, Contractor shall be paid pro rata for all services actually rendered up to the effective date of termination.

10. Final Agreement.

This Agreement is the final expression of the agreement between the parties, and the complete and exclusive statement of the terms agreed upon, and shall supersede all prior negotiations, understandings or agreements. There are no representations, warranties, or stipulations either oral or written, not contained herein.

11. Modifications.

Any alterations, variations, modifications or waivers of the provisions of this Agreement shall only be valid when they have been reduced to writing and signed by authorized representatives of the party against whom enforcement is sought.

12. Severability.

The provisions of this Agreement shall be deemed severable. If any part of this Agreement is rendered void, invalid or unenforceable, such rendering shall not affect the enforceability of the remainder of this Agreement unless the part or parts which are void, invalid or otherwise unenforceable shall be substantially impair the value of the entire agreement with respect to any party.

13. Law Governing.

This Agreement will be governed by the laws of the State of Alabama. The appropriate venue for any actions arising out of this Agreement would be Baldwin County, Alabama.

14. Permits, etc.

Contractor shall obtain, at its own expense, all necessary licenses, permits, insurance, authorizations and assurances necessary in order to abide by the terms of this Agreement.

15. Confidentiality.

Contractor (including its employees, agents, subcontractors) acknowledges that all confidential business and personal information (“Protected Information”) that it may obtain while performing services for the City, is deemed confidential and proprietary to the City. During Contractor’s tenure with the City, Contractor agrees to use Protected Information only and strictly as required to perform its services on behalf of the City. Contractor will not disclose Protected Information to any person or entity without the prior written consent of the City and the written agreement of any third party. Contractor agrees to refer any request for public information or records to the City Clerk, who is the custodian of records for the City and is responsible for the disclosure of public records in accordance with the public records laws of the state. Contractor agrees that it will not duplicate or incorporate Protected Information into its own records or databases and that after the conclusion of its services to the City all Protected Information in the Contractor’s possession will be turned over to the City. Contractor agrees not to disclose, use, transfer, or transmit the information to any person or entity for any purpose whatsoever. This includes records, passwords, access codes, manuals, statistics, software, audio/video recordings, or storage disks of any kind containing Protected Information.

16. Notices.

All notices of cancellation, requests, demands, or other communications shall be in writing and duly delivered to the addresses appearing below:

City of Orange Beach
City Clerk
Post Office Box 458
Orange Beach, Alabama 36561

With Required Copy to:
City Attorney
Post Office Box 458
Orange Beach, Alabama 36561

And to Contractor
Socialize Your Bizness
30365 Ono North Loop W
Orange Beach, Alabama 36561

IN WITNESS WHEREOF, we have hereunto set our hands and seals on this the ____ day of _____, 2025.

CITY OF ORANGE BEACH
An Alabama Municipal Corporation

By: _____
Tony Kennon, Mayor

ATTEST:

Renee Eberly, City Clerk

SOCIALIZE YOUR BIZNESS, INC.
An Alabama Corporation

By: _____
Cindy Ross, Owner

STATE OF ALABAMA
COUNTY OF BALDWIN

I, the undersigned Notary Public in and for said County in said State, hereby certify that Tony Kennon and Renee Eberly, whose names as Mayor and City Clerk, respectively, of the City of Orange Beach, a Municipal Corporation, are signed to the foregoing agreement, and who are known to me, acknowledged before me on this day, that, being informed of the contents of the above and foregoing, they, as such officers and with full authority, executed the same voluntarily for and as the act of said municipal corporation on the day the same bears date.

Given under my hand and seal this the _____ day of _____, 2025.

(SEAL)

Notary Public
State of Alabama At-Large
My Commission Expires: _____

STATE OF ALABAMA
COUNTY OF _____

I, the undersigned Notary Public, in and for said county in said state, hereby certify that Cindy Ross, whose name as Owner of Socialize Your Bizness, Inc., an Alabama corporation, is signed to the foregoing agreement, and who is known to me, acknowledged before me on this day that, being informed of the contents of the above and foregoing agreement, he as such officer and with full authority, executed the same voluntarily for and as the act of said corporation on the day the same bears date.

Given under my hand and seal this the _____ day of _____, 2025.

(SEAL)

Notary Public
State of Alabama At-Large
My Commission Expires: _____



**REGULAR CITY COUNCIL MEETING
DECEMBER 16, 2025**

Departments: City Clerk

Description of Topic: Resolution authorizing execution of a professional services agreement with Bob Riley and Associates, LLC, for lobbying services.

Background/Description: Contract renewal for lobbyist services.

Action Options/Recommendation:

Source of Funding (if applicable): Budgeted, Admin Professional Services, \$120,000 for FY2026

ATTACHMENTS:

1. 12-16-25 25-xxx Authorize Professional Services Agreement Bob Riley Associates Lobbyist
2. 2025.11.26 Professional Services Agreement Bob Riley Associates

RESOLUTION NO. 25-xxx

**A RESOLUTION AUTHORIZING EXECUTION OF A
PROFESSIONAL SERVICES AGREEMENT WITH
BOB RILEY AND ASSOCIATES, LLC, FOR LOBBYING SERVICES**

FINDINGS:

1. The City Council for the City of Orange Beach, Alabama, has reviewed the performance of Bob Riley and Associates, LLC, as lobbyist for the City.
2. The City Council desires to utilize the services of Bob Riley and Associates, LLC, to provide the City with direct representation and public affairs support services, to include lobbying during the regular and special legislative sessions and support at the state level.
3. The term of this agreement shall be for twelve (12) months commencing January 1, 2026, and ending December 31, 2026.

NOW, THEREFORE, BE IT RESOLVED BY THE CITY COUNCIL OF THE CITY OF ORANGE BEACH, ALABAMA, AS FOLLOWS:

1. That the Council authorizes the Mayor and City Clerk to execute and attest, respectively, the agreement (attached Exhibit A) in substantially the form and of substantially the content now before the Council between the City of Orange Beach and Bob Riley and Associates, LLC, as an act for and on behalf of the City of Orange Beach subject to final approval by the City Attorney; and
2. That this Resolution shall become effective upon its adoption.

ADOPTED THIS 16th DAY OF DECEMBER, 2025.

Renee Eberly
City Clerk

C E R T I F I C A T E

I, Renee Eberly, City Clerk of the City of Orange Beach, Alabama, do hereby certify that the foregoing is a true and correct copy of Resolution No. 25-xxx, which was duly and legally adopted at a regular meeting of the City Council on December 16, 2025.

City Clerk

PROFESSIONAL SERVICES CONTRACT

This Agreement is made and entered into by and between the City of Orange Beach, an Alabama municipal corporation (the “City”) and Bob Riley and Associates, LLC, an Alabama Limited Liability Corporation (sometimes hereinafter “Contractor”), as follows:

1. Recitals.

WHEREAS, Contractor is a consulting firm that employs one or more registered lobbyists to provide representation and public affairs support concerning legislative matters of interest to the City;

WHEREAS, Contractor also provides general consulting services for projects and issues outside Montgomery;

WHEREAS, the City desires to engage Contractor to provide said services upon the following terms and conditions;

NOW, THEREFORE, for and in consideration of the mutual covenants and agreements hereinafter set forth to be kept and performed by the other, and other good and valuable consideration, the receipt and sufficiency of all of which are hereby acknowledged, the parties do hereby covenant and agree as follows:

2. Scope of Services.

Contractor will provide lobbyists, direct representation and public affairs support services concerning legislative issues, more particularly described below. Contractor will use its best efforts in representing City and:

Lobbying and Direct Representation

- (a) Work with the Mayor and Council to identify issues of importance to City that are impacted by state government and assist in the favorable resolution of such issues;
- (b) Support the Mayor and Council as they work to meet the infrastructure needs of the community to allow for continued smart growth and development including, interaction with state agencies such as the Departments of Transportation, Environmental Management, Conservation and Natural Resources and others;
- (c) Provide an enhanced presence at the Alabama Department of Transportation to focus attention on key transportation needs and issues including the widening of Canal Road, developing a southern alternative evacuation route, extending the Foley Beach Express to I-10 and ultimately to I-65 and building a second bridge off the island;
- (d) Assist in coordinating meetings and events in Baldwin County to target members of the legislative leadership and members of key legislative committees to highlight the opportunities for growth and development of the community and its positive impact on the state of Alabama;
- (e) Provide a point of contact between the Mayor and Council and the local legislative delegation, and work to develop and enhance those relationships to further the City’s interests;
- (f) Monitor and provide lobbying services on any legislative issues of importance to the city including local legislation and matters of statewide impact; read and analyze first readings in the House and the Senate throughout the sessions; represent the city on any matters of concern and interest before the legislature;
- (g) Coordinate with the City’s Washington lobbyist on federal issues.

General Consulting / Public Affairs

- (h) Work with the Mayor and Council to implement a communications plan including op-eds, letters to the editor, editorial board briefings and other elements to gain earned media support for the city of Orange Beach in order to support the continued growth and development of the community. These activities will be designed to support the Mayor and Council with key state policy makers and the public, thereby enhancing the community's interaction and efforts at the state level.

3. Warranties and Representations.

Contractor warrants and represents that:

- (a) Contractor and all of its agents and employees will abide by all laws relating to the activities to be performed under this agreement, including where applicable, registration with the Alabama Ethics Commission;
- (b) Contractor will promptly report to City any complaints or investigations initiated by the Alabama Ethics Commission or other regulatory body;
- (c) Contractor will disclose in writing to Mayor and City Administrator any conflict of interest should the same arise during the term of this contract, and advise how Contractor proposes to handle such conflict;

4. Compensation.

As full and total compensation for the services to be provided pursuant to this agreement, Contractor shall be paid \$10,000.00 monthly, plus actual and reasonable expenses. Said payments shall be made upon receipt of an Invoice from Contractor. All out of state travel must be approved in advance by the Mayor.

5. Term.

The term of this agreement shall commence on January 1, 2026, and end on December 31, 2026, unless terminated earlier in accordance with paragraph 10. This agreement may be renewed annually by resolution adopted by the City Council.

6. Independent Contractor.

Notwithstanding any of the provisions of this Agreement, it is agreed that City has no financial interest in the business of Contractor and shall not be liable for any debts or obligations incurred by Contractor, nor shall City be deemed or construed to be a partner, joint venturer or otherwise interested in the assets of Contractor, or in the sums earned or derived by Contractor, nor shall Contractor at any time or times use the name or credit of City in purchasing or attempting to purchase any car, equipment, supplies or other thing or things whatsoever.

Contractor, in the performance of its operations and obligations hereunder, shall not be deemed to be an agent of City but shall be deemed to be an independent Contractor in every respect and shall take all steps at its own expense, as City may from time to time request, to indicate that it is an independent Contractor. City does not and will not assume any responsibility for the means by which or the manner in which the services by Contractor provided for herein are performed, but on the contrary, Contractor shall be wholly responsible therefor.

7. Insurance.

For the term of this Agreement, the Contractor shall acquire and maintain in full force and effect insurance naming the City as an additional insured, as reflected in the Certificate of Insurance attached hereto as Exhibit "A".

8. Assignment.

Contractor acknowledges that its identity and peculiar capacity to provide the services described hereinabove constitute a material consideration for City's having entered into this Agreement. Therefore, Contractor shall not transfer or assign this Agreement or any of the rights or privileges granted herein without the prior written consent of City; which such consent shall be granted or denied solely at City's discretion.

9. Compliance with Law.

Contractor hereby agrees to comply strictly with all the laws of the State of Alabama and of the United States, and the laws and ordinances of any other jurisdiction in which contractor may perform any work pursuant to this agreement.

10. Termination.

This agreement may be terminated by either party for any reason upon sixty (60) days notice of the intent to terminate. Upon termination, Contractor shall be paid pro rata for all services actually rendered up to the effective date of termination.

11. Final Agreement.

This Agreement is the final expression of the agreement between the parties, and the complete and exclusive statement of the terms agreed upon, and shall supersede all prior negotiations, understandings or agreements. There are no representations, warranties, or stipulations, either oral or written, not contained herein.

12. Modifications.

Any alterations, variations, modifications, or waivers of the provisions of this Agreement shall only be valid when they have been reduced to writing and signed by authorized representatives of the party against whom enforcement is sought.

13. Severability.

The provisions of this Agreement shall be deemed severable. If any part of this Agreement is rendered void, invalid or unenforceable, such rendering shall not affect the enforceability of the remainder of this Agreement unless the part or parts which are void, invalid or otherwise unenforceable shall substantially impair the value of the entire agreement with respect to any party.

14. Law Governing.

This Agreement shall be governed by the laws of the State of Alabama, and the appropriate venue for any actions arising out of this Agreement would be Baldwin County, Alabama.

15. Permits, etc.

Contractor shall obtain, at its own expense, all necessary licenses, permits, insurance, authorizations and assurances necessary in order to abide by the terms of this Agreement.

16. Notices.

All notices of cancellation, requests, demands, or other communications shall be in writing and duly delivered to the addresses appearing below:

City of Orange Beach:

City Clerk
Post Office Box 458
Orange Beach, Alabama 36561

With Required Copy to:

City Attorney
Post Office Box 458
Orange Beach, Alabama 36561

And to Contractor:

Bob Riley and Associates, LLC
3530 Independence Drive
Birmingham, Alabama 35209

IN WITNESS WHEREOF, we have hereunto set our hands and seal on this the _____ day
of _____, 2025.

CITY OF ORANGE BEACH,
An Alabama Municipal Corporation

By: _____
Tony Kennon, Mayor

ATTEST:

Renee Eberly, City Clerk

BOB RILEY AND ASSOCIATES, LLC

By: _____
Robert R. Riley, Owner

STATE OF ALABAMA

COUNTY OF BALDWIN

I, the undersigned Notary Public in and for said County in said State, hereby certify that Tony Kennon and Renee Eberly, whose names as Mayor and City Clerk, respectively, of the City of Orange Beach, a Municipal Corporation, are signed to the foregoing agreement, and who are known to me, acknowledged before me on this day, that, being informed of the contents of the above and foregoing, they, as such officers and with full authority, executed the same voluntarily for and as the act of said municipal corporation on the day the same bears date.

Given under my hand and seal this the _____ day of _____, 2025.

(SEAL)

Notary Public
State of Alabama At-Large
My Commission Expires: _____

STATE OF ALABAMA

COUNTY OF _____

I, the undersigned Notary Public, in and for said county in said state, hereby certify that Robert R. Riley, whose name as Owner of Bob Riley and Associates, Inc., a limited liability corporation, is signed to the foregoing agreement, and who is known to me, acknowledged before me on this day that, being informed of the contents of the above and foregoing agreement, he as such officer and with full authority, executed the same voluntarily for and as the act of said corporation on the day the same bears date.

Given under my hand and seal this the _____ day of _____, 2025.

(SEAL)

Notary Public
State of Alabama At-Large
My Commission Expires: _____



**REGULAR CITY COUNCIL MEETING
DECEMBER 16, 2025**

Departments: City Clerk

Description of Topic: Resolution authorizing execution of a professional services agreement with Van Scoyoc Associates for consulting services.

Background/Description: Renewal of contract for lobbyist services.

Action Options/Recommendation:

Source of Funding (if applicable): Budgeted, Admin Professional Services, \$72,000 for FY2026

ATTACHMENTS:

1. 12-16-25 25-xxx Authorize Professional Services Agreement Van Scoyoc Associates Consultant
2. 2025.11.26 Professional Services Agreement Van Scoyoc Associates

RESOLUTION NO. 25-xxx

**A RESOLUTION AUTHORIZING EXECUTION OF A
PROFESSIONAL SERVICES AGREEMENT WITH
VAN SCOYOC ASSOCIATES FOR CONSULTING SERVICES**

FINDINGS:

1. The City Council for the City of Orange Beach, Alabama, has reviewed the performance of Van Scoyoc Associates as consultants and advisors with regard to various federal agencies and legislative issues.
2. After having reviewed such performance, the City Council has determined that the continuing services of Van Scoyoc Associates are in the best interests of the City of Orange Beach, Alabama.
3. The term of this agreement shall be for twelve (12) months commencing January 1, 2026, and ending December 31, 2026.

NOW, THEREFORE, BE IT RESOLVED BY THE CITY COUNCIL OF THE CITY OF ORANGE BEACH, ALABAMA, AS FOLLOWS:

1. That the Council authorizes the Mayor and City Clerk to execute and attest, respectively, the agreement (attached Exhibit A) in substantially the form and of substantially the content now before the Council between the City of Orange Beach and Van Scoyoc Associates as an act for and on behalf of the City of Orange Beach subject to final approval by the City Attorney; and
2. That this Resolution shall become effective upon its adoption.

ADOPTED THIS 16th DAY OF DECEMBER, 2025.

Renee Eberly
City Clerk

C E R T I F I C A T E

I, Renee Eberly, City Clerk of the City of Orange Beach, Alabama, do hereby certify that the foregoing is a true and correct copy of Resolution No. 25-xxx, which was duly and legally adopted at a regular meeting of the City Council on December 16, 2025.

City Clerk

PROFESSIONAL SERVICES CONTRACT

This Agreement is made and entered into by and between the City of Orange Beach, a Class 8 Alabama municipal corporation (hereinafter the "City") and Van Scoyoc Associates, a corporation duly formed and existing under the laws of the District of Columbia (hereinafter the "Contractor"), as follows:

1. Recitals.

WHEREAS, the City desires to engage Contractor to provide representation and public affairs support concerning various federal legislative issues;

WHEREAS, the Contractor is skilled in providing such services and is available and willing to perform such services on the terms and conditions set forth in this Agreement;

NOW, THEREFORE, for and in consideration of the mutual covenants and agreements hereinafter set forth to be kept and performed by the other, and other good and valuable consideration, the receipt and sufficiency of all of which are hereby acknowledged, the parties to hereby covenant and agree as follows:

2. Retainer.

The City hereby retains Contractor as consultants and advisors with regard to various federal legislative issues.

3. Consulting Services to be Performed.

Contractor undertakes to monitor and evaluate various federal legislative issues and to advise the City on the components of an agency and legislative plan and the appropriate strategy necessary to achieve the goals of such a plan.

Contractor will perform such other services with regard to federal legislative issues as are mutually agreed to between the Contractor and the City.

4. Compensation.

As full and total compensation for the services to be provided pursuant to this Agreement, Contractor shall be paid the sum of \$6,000.00 per month, plus actual and reasonable expenses. For the purposes of this Agreement, reasonable expenses include charges for telephone, fax and transportation expenses actually incurred in the performance of services under this Agreement and directly attributable thereto. The City represents and warrants that these payments shall not be made with federally appropriated funds.

Contractor agrees to abide by the City's established travel policies, and agrees that any long distance travel and entertainment must be approved in advance by the City Administrator.

Contractor shall be paid monthly, in advance, upon the City's receipt of a properly documented invoice.

5. Term.

The term of this Agreement is twelve (12) months commencing January 1, 2026, and ending December 31, 2026.

6. Independent Contractor.

Notwithstanding any of the provisions of this Agreement, it is agreed that the City has no financial interest in the business of Contractor and shall not be liable for any debts or obligations incurred

by Contractor, nor shall City be deemed or construed to be a partner, joint venturer or otherwise interested in the assets of Contractor, or in the sums earned or derived by Contractor.

Contractor, in the performance of its operations and obligations hereunder, shall not be deemed to be an agent of City but shall be deemed to be an independent Contractor in every respect and shall take all steps at its own expense as City may from time to time request to indicate that it is an independent Contractor. City does not, and will not, assume any responsibility for the means by which or the manner in which the services by Contractor provided for herein are performed but, on the contrary, Contractor shall be wholly responsible therefor.

7. Insurance.

For the term of this Agreement, the Contractor shall acquire and maintain in full force and affect the policy of insurance evidenced by the certificate of insurance attached hereto, with the City being named as an additional insured.

Said certificate shall require that said insurance coverage will not be altered or terminated unless City shall be given written notice of such alteration or termination delivered to City not less than thirty (30) days before the effective date of such alteration or termination.

8. Assignment.

Contractor acknowledges that its identity and peculiar capacity to provide the services described hereinabove constitute a material consideration for City's having entered into this Agreement. Therefore, Contractor shall not transfer or assign this

Agreement or any of the rights or privileges granted herein without the prior written consent of City; which consent shall be granted or denied solely at City's discretion.

9. Compliance with Law.

Contractor hereby agrees to comply strictly with all the laws of the State of Alabama and of the United States, and the laws and ordinances of any other jurisdiction in which contractor may perform any work pursuant to this Agreement. It is understood that Contractor will be required to register on behalf of the City under the terms of the Lobbying Disclosure Act of 1995, as amended (2 USC §1601 et seq.) and any subsequent laws or regulations.

10. Termination.

Contractor agrees that upon the violation of any of the covenants and agreements herein contained, on account of any act or omission or commission of Contractor, City may, at its option, terminate and cancel this Agreement and have no further obligation to Contractor.

This Agreement may also be terminated by either party for any reason upon thirty (30) days notice of the intent to terminate. Upon termination, Contractor shall be paid pro rata for all services actually rendered up to the effective date of termination.

11. Final Agreement.

This Agreement is the final expression of the Agreement between the parties, and the complete and exclusive statement of the terms agreed upon, and shall supersede all prior negotiations, understandings or agreements. There are no representations, warranties, or stipulations, either oral or written, not contained herein.

12. Modifications.

Any alterations, variations, modifications or waivers of the provisions of this Agreement shall only be valid when they have been reduced to writing and signed by authorized representatives of both parties.

13. Severability.

The provisions of this Agreement shall be deemed severable. If any part of this Agreement is rendered void, invalid or unenforceable, such rendering shall not affect the enforceability of the remainder of this Agreement unless the part or parts which are void, invalid or otherwise unenforceable shall substantially impair the value of the entire Agreement with respect to either party.

14. Law Governing.

This Agreement shall be governed by the laws of the State of Alabama, and the appropriate venue for any actions arising out of this Agreement would be Baldwin County, Alabama.

15. Permits, etc.

Contractor shall obtain, at its own expense, all necessary licenses, permits, insurance, authorizations and assurances necessary in order to abide by the terms of this Agreement.

16. Notices.

All notices of cancellation, requests, demands or other communications shall be in writing and duly delivered to the addresses appearing below:

City of Orange Beach
City Clerk
Post Office Box 458
Orange Beach, AL 36561

Copy to:
City Attorney
P.O. Box 458
Orange Beach, AL 36561

And to Contractor: Van Scoyoc Associates, Inc.
800 Maine Avenue, SW, Suite 800
Washington, DC 20024
Attn: Brian Robinson, General Counsel

IN WITNESS WHEREOF, we have hereunto set our hands and seal on this the _____ day of _____, 2025.

CITY OF ORANGE BEACH

By: _____
Tony Kennon, Mayor

ATTEST:

Renee Eberly, City Clerk

VAN SCOYOC ASSOCIATES, INC.

By: _____
H. Stewart Van Scoyoc
Chairman, Founder, and CEO

STATE OF ALABAMA

COUNTY OF BALDWIN

I, the undersigned Notary Public in and for said County in said State, hereby certify that Tony Kennon and Renee Eberly, whose names as Mayor and City Clerk, respectively, of the City of Orange Beach, a Municipal Corporation, are signed to the foregoing agreement, and who are known to me, acknowledged before me on this day, that, being informed of the contents of the above and foregoing, they, as such officers and with full authority, executed the same voluntarily for and as the act of said municipal corporation on the day the same bears date.

Given under my hand and seal this the _____ day of _____, 2025.

(SEAL)

Notary Public
State of Alabama At-Large
My Commission Expires: _____

STATE OF ALABAMA

COUNTY OF _____

I, the undersigned Notary Public, in and for said county in said state, hereby certify that H. Stewart Van Scoyoc, whose name as Chairman, Founder, and CEO of Van Scoyoc Associates, Inc., a corporation duly formed and existing under the laws of the District of Columbia, is signed to the foregoing agreement, and who is known to me, acknowledged before me on this day that, being informed of the contents of the above and foregoing agreement, he as such officer and with full authority, executed the same voluntarily for and as the act of said corporation on the day the same bears date.

Given under my hand and seal this the _____ day of _____, 2025.

(SEAL)

Notary Public
State of Alabama At-Large
My Commission Expires: _____



**REGULAR CITY COUNCIL MEETING
DECEMBER 16, 2025**

Departments: City Clerk

Description of Topic: Resolution authorizing execution of a professional services agreement with Adams and Reese, LLP, for federal and state governmental relations and consulting services.

Background/Description:

Action Options/Recommendation:

Source of Funding (if applicable):

ATTACHMENTS:

1. 12-16-25 25-xxx Authorize Professional Services Agreement Adams and Reese Lobbyist
2. 2025.12.09 Professional Services Agreement Adams and Reese Lobbyist

RESOLUTION NO. 25-xxx

**A RESOLUTION AUTHORIZING EXECUTION OF A
PROFESSIONAL SERVICES AGREEMENT WITH ADAMS AND REESE, LLP, FOR
FEDERAL AND STATE GOVERNMENTAL RELATIONS AND CONSULTING SERVICES**

FINDINGS:

1. The City Council for the City of Orange Beach, Alabama, has reviewed the performance of Adams and Reese, LLP, as lobbyist for the City.
2. The City Council desires to utilize the services of Adams and Reese, LLP, to provide the City with governmental relations and consulting services during the regular and special legislative sessions at both the State and Federal level.
3. The term of this agreement shall be for the period commencing January 1, 2026, and ending December 31, 2026.

NOW, THEREFORE, BE IT RESOLVED BY THE CITY COUNCIL OF THE CITY OF ORANGE BEACH, ALABAMA, AS FOLLOWS:

1. That the Council authorizes Mayor and City Clerk to execute and attest, respectively, the agreement (attached Exhibit A) in substantially the form and of substantially the content now before the Council between the City of Orange Beach and Adams and Reese, LLP, as an act for and on behalf of the City of Orange Beach, subject to final approval by the City Attorney; and
2. That this Resolution shall become effective upon its adoption.

ADOPTED THIS 16th DAY OF DECEMBER, 2025.

Renee Eberly
City Clerk

C E R T I F I C A T E

I, Renee Eberly, City Clerk of the City of Orange Beach, Alabama, do hereby certify that the foregoing is a true and correct copy of Resolution No. 25-xxx, which was duly and legally adopted at a regular meeting of the City Council on December 16, 2025.

City Clerk

PROFESSIONAL SERVICES CONTRACT

This Agreement is made and entered into by and between the City of Orange Beach, an Alabama municipal corporation (the “City”) and Adams and Reese, LLP, a Limited Liability Partnership (sometimes hereinafter “Contractor”), as follows:

1. Recitals.

WHEREAS, Contractor is a consulting firm that employs one or more attorneys and government relations advisors to provide representation and public affairs support concerning projects and legislative matters of interest to the City at the State and Federal level;

WHEREAS, Contractor provides Federal and State Governmental Relations and Consulting Services;

WHEREAS, the City desires to engage Contractor to provide said services on the terms and conditions as set out herein.

NOW, THEREFORE, for and in consideration of the mutual covenants and agreements hereinafter set forth to be kept and performed by the other, and other good and valuable consideration, the receipt and sufficiency of all of which are hereby acknowledged, the parties do hereby covenant and agree as follows:

2. Scope of Services.

Contractor will provide lobbyists, direct representation and public affairs support services concerning legislative issues, more particularly described below. Contractor will use its best efforts in representing City and:

Federal Representation

- (a) Work with the Mayor and Council, and other designated staff, to discuss projects of importance to Orange Beach, both on-going and potential projects;
- (b) Work with the City’s current grants and federally funded projects team and perform a review of the City’s current process for submitting projects for Congressionally directed appropriations, evaluate its effectiveness, if needed refine the process going forward so the City is fully utilizing all its resources possible, and ensuring all their efforts will thoroughly compliment the City’s current efforts;
- (c) Work to present funding opportunities to the City on an ongoing basis for consideration based on the City’s priorities with direct input from Members of Congress and their staffs. Contractor will work with Members, and staffers as wells as state officials where needed regarding all funding requests, as well as with specific Executive Branch and agency contacts;
- (d) Organize and arrange visits by authorized representatives of the City to Washington, D.C. to visit with the Alabama Federal Delegation, House and Senate leadership and appropriate Executive Branch or Committee staff on each project or funding opportunity being pursued on behalf of the City;
- (e) Work through the legislative year with the Alabama Federal Delegation, House and Senate leadership, Committee and Subcommittee Staff and appropriate agency officials to help ensure the success , and their support, for the City’s projects and priorities;
- (f) Monitor and engage on behalf of the City on various authorization and regulatory issues identified as important to the City during the course of the legislative year. Contractor will provide regular updates on issues of importance to the City as they occur in Washington, D.C.;

State Representation

- (g) Develop a strategy in advance of the State legislative session based on the priorities of the City then implement and monitor the session(s) and committee hearings to provide real-time updates during the session on issues of importance to the City;
- (h) Report findings from meetings or other special events to keep the City updated on a regular basis. Contractor's professionals will remain immediately available to answer questions concerning legislative activity that could impact the City throughout the session;
- (i) Work with Alabama League of Municipalities on specific issues and legislation of importance to the City;
- (j) Represent the City at public hearings in Montgomery, and presenting the City's point of view to lawmakers, other decisions makers, agency representatives and the public;
- (k) Provide the City with the advanced notice needed to act quickly on issues critical to issues of importance to the City or items of concern to the City;
- (l) Assist in developing and promoting legislation important to the City's continued growth and success, including assistance with any local legislation;
- (m) Provide issue management, research services and other consulting services when needed to ensure a seamless integration between efforts made on behalf of the City at both State and Federal levels

Implementation

- (n) Contractor will take the following actions within the initial 30 days of this agreement:
 - (1) Meet with designated City representative(s) to review and discuss all pending, potential, and/or recent funding requests congressionally directed appropriation requests and discuss other pressing matters of importance to the City;
 - (2) Fully evaluate the City's current grant evaluating and submission process in order to strengthen its efficiency and provide comprehensive analysis and funding strategy going forward at both the Federal and State level;
 - (3) Contact appropriate Congressional and Senate staff members to ensure the Member and Senators are aware of any current pending funding requests and solicit and confirm their support for the requested funding as well as with all state agencies and state officials where needed.
 - (4) When appropriate, contact any federal or state agency representatives and arrange de-briefings to have the agency review the reasons any recently submitted funding requests were not awarded and evaluate if a modified grant application should be prepared and submitted for any subsequent funding opportunities.

3. Warranties and Representations.

Contractor warrants and represents that:

- (a) Contractor and all of its agents and employees will abide by all laws relating to the activities

to be performed under this agreement, including where applicable, registration with the Alabama Ethics Commission;

- (b) Contractor will promptly report to City any complaints or investigations initiated by the Alabama Ethics Commission or other regulatory body;
- (c) Contractor will disclose in writing to Mayor and City Administrator any conflict of interest should the same arise during the term of this contract, and advise how Contractor proposes to handle such conflict;

4. Compensation.

As full and total compensation for the services to be provided pursuant to this agreement, Contractor shall be paid \$9,750.00 monthly, plus actual and reasonable expenses approved in advance by the City or its authorized representatives. Said payments shall be made upon receipt of an Invoice from Contractor. All out of state travel must be approved in advance by the Mayor.

5. Term.

The term of this agreement shall commence on January 1, 2026, and end on December 31, 2026, unless terminated earlier in accordance with paragraph 10.

6. Independent Contractor.

Notwithstanding any of the provisions of this Agreement, it is agreed that City has no financial interest in the business of Contractor and shall not be liable for any debts or obligations incurred by Contractor, nor shall City be deemed or construed to be a partner, joint venturer or otherwise interested in the assets of Contractor, or in the sums earned or derived by Contractor, nor shall Contractor at any time or times use the name or credit of City in purchasing or attempting to purchase any car, equipment, supplies or other thing or things whatsoever.

Contractor, in the performance of its operations and obligations hereunder, shall not be deemed to be an agent of City but shall be deemed to be an independent Contractor in every respect and shall take all steps at its own expense, as City may from time to time request, to indicate that it is an independent Contractor. City does not and will not assume any responsibility for the means by which or the manner in which the services by Contractor provided for herein are performed, but on the contrary, Contractor shall be wholly responsible therefor.

7. Insurance.

For the term of this Agreement, the Contractor shall acquire and maintain in full force and effect general liability insurance and workman's compensation insurance as required by law.

8. Assignment.

Contractor acknowledges that its identity and peculiar capacity to provide the services described hereinabove constitute a material consideration for City's having entered into this Agreement. Therefore, Contractor shall not transfer or assign this Agreement or any of the rights or privileges granted herein without the prior written consent of City; which such consent shall be granted or denied solely at City's discretion.

9. Compliance with Law.

Contractor hereby agrees to comply strictly with all the laws of the State of Alabama and of the United States, and the laws and ordinances of any other jurisdiction in which contractor may

perform any work pursuant to this agreement.

10. Termination.

This agreement may be terminated by either party for any reason upon thirty (30) days notice of the intent to terminate. Upon termination, Contractor shall be paid pro rata for all services actually rendered up to the effective date of termination.

11. Final Agreement.

This Agreement is the final expression of the agreement between the parties, and the complete and exclusive statement of the terms agreed upon, and shall supersede all prior negotiations, understandings or agreements. There are no representations, warranties, or stipulations, either oral or written, not contained herein.

12. Modifications.

Any alterations, variations, modifications, or waivers of the provisions of this Agreement shall only be valid when they have been reduced to writing and signed by authorized representatives of the party against whom enforcement is sought.

13. Severability.

The provisions of this Agreement shall be deemed severable. If any part of this Agreement is rendered void, invalid or unenforceable, such rendering shall not affect the enforceability of the remainder of this Agreement unless the part or parts which are void, invalid or otherwise unenforceable shall substantially impair the value of the entire agreement with respect to any party.

14. Law Governing.

This Agreement shall be governed by the laws of the State of Alabama, and the appropriate venue for any actions arising out of this Agreement will be Baldwin County, Alabama.

15. Permits, etc.

Contractor shall obtain, at its own expense, all necessary licenses, permits, insurance, authorizations and assurances necessary in order to abide by the terms of this Agreement.

16. Notices.

All notices of cancellation, requests, demands, or other communications shall be in writing and duly delivered to the addresses appearing below:

City of Orange Beach:

City Clerk
Post Office Box 458
Orange Beach, Alabama 36561

With Required Copy to:

City Attorney
Post Office Box 458
Orange Beach, Alabama 36561

And to Contractor:

Adams and Reese, LLP
11 North Water Street
Suite 23200
Mobile, Alabama 36602

IN WITNESS WHEREOF, we have hereunto set our hands and seal on this the _____ day
of _____, 2025.

CITY OF ORANGE BEACH,
An Alabama Municipal Corporation

By: _____
Tony Kennon, Mayor

ATTEST:

Renee Eberly, City Clerk

ADAMS AND REESE, LLP

By: _____
C. Britton Bonner, Partner

STATE OF ALABAMA

COUNTY OF BALDWIN

I, the undersigned Notary Public in and for said County in said State, hereby certify that Tony Kennon and Renee Eberly, whose names as Mayor and City Clerk, respectively, of the City of Orange Beach, a Municipal Corporation, are signed to the foregoing agreement, and who are known to me, acknowledged before me on this day, that, being informed of the contents of the above and foregoing, they, as such officers and with full authority, executed the same voluntarily for and as the act of said municipal corporation on the day the same bears date.

Given under my hand and seal this the _____ day of _____, 2025.

(SEAL)

Notary Public
State of Alabama At-Large
My Commission Expires: _____

STATE OF ALABAMA

COUNTY OF _____

I, the undersigned Notary Public, in and for said county in said state, hereby certify that C. Britton Bonner, whose name as Partner of Adams and Reese, LLP, a limited liability partnership, is signed to the foregoing agreement, and who is known to me, acknowledged before me on this day that, being informed of the contents of the above and foregoing agreement, he as such officer and with full authority, executed the same voluntarily for and as the act of said corporation on the day the same bears date.

Given under my hand and seal this the _____ day of _____, 2025.

(SEAL)

Notary Public
State of Alabama At-Large
My Commission Expires: _____



**REGULAR CITY COUNCIL MEETING
DECEMBER 16, 2025**

Departments: City Clerk

Description of Topic: Resolution authorizing the purchase of Furniture for the Municipal Court through the BuyBoard Purchasing Cooperative from MityLite Inc. in the amount of \$32,847.64.

Background/Description:

Action Options/Recommendation:

Source of Funding (if applicable): Budgeted for FY2026.

ATTACHMENTS:

1. 12-16-25 25-xxx Authorize Purchase Furniture Court BuyBoard
2. 2025.12.12 Quote - Court - MityLite Chairs

RESOLUTION NO. 25-xxx

**A RESOLUTION AUTHORIZING THE PURCHASE OF
FURNITURE FOR THE MUNICIPAL COURT
THROUGH THE BUYBOARD PURCHASING COOPERATIVE
FROM MITYLITE INC. IN THE AMOUNT OF \$32,847.64**

BE IT RESOLVED BY THE CITY COUNCIL OF THE CITY OF ORANGE BEACH, ALABAMA, AS FOLLOWS:

1. That the City Council for the City of Orange Beach, Alabama, hereby authorizes the purchase of Furniture for the Municipal Court through the BuyBoard purchasing cooperative, approved by the State of Alabama and the Public Examiners Office, in the amount of \$32,847.64;
2. That the Mayor is hereby authorized to approve payment to MityLite Inc. in the amount of \$32,847.64 for 200 Chairs, 12 Tables, and Two Carts with delivery, per Quote No. SQ82083 dated December 12, 2025;
3. That the equipment as described in this Resolution is to be used only for official business of the City of Orange Beach; and
4. That this Resolution shall become effective upon its adoption.

ADOPTED THIS 16th DAY OF DECEMBER, 2025.

Renee Eberly
City Clerk

C E R T I F I C A T E

I, Renee Eberly, City Clerk of the City of Orange Beach, Alabama, do hereby certify that the foregoing is a true and correct copy of Resolution No. 25-xxx, which was duly and legally adopted at a regular meeting of the City Council on December 16, 2025.

City Clerk

QUOTE ACKNOWLEDGEMENT

THIS IS NOT AN INVOICE



Created On: 12/12/2025

Sales Quote Number: SQ82083

Mity Customer Number: A0124410

Page: 1 Of 2



Bill To:	Sell To:	Ship To:
City of Orange Beach Pamela Davis 4480 Orange Beach Blvd Orange Beach, AL 36561 United States	City of Orange Beach Pamela Davis 4480 Orange Beach Blvd Orange Beach, AL 36561 United States	City of Orange Beach Pamela Davis 4480 Orange Beach Blvd Orange Beach, AL 36561 United States

Ship Via	Payment Terms	Sales Person
ORIGIN, Freight Prepaid	Payment Terms Pending	Scott Bean

Item No.	Description	UOM	QTY	Unit Price	Total Price
CLHG	CLASSIC HOURGLASS-QUOTE Finish:Urban Bronze Back:Fixed Leg:Standard Ganging: Wire Glide:Nickel SeatUpholstery:Scatter - Flint Seat Cushion: Waterfall Seat	Each	200	\$130.61	\$26,122.00
RT3072GRB0213060000	RT 3072 GRB W30BLK ABS RECTANGLE TABLE 30" X 72" Top: Grey Bottom: Black Trim ABS Black Leg: Wishbone Leg/Base Color: Black Sand Height: 30in. Tall	Each	12	\$235.66	\$2,827.92
CRT5WCHHTBLK2V2	CART 5 WHEEL COMFORT BLK V2 COMFORT SEATING CART-5 WHEEL V2, BLACK; HOLDS 8,OR 10 ENCORE, CLASSIC, E2, OR ACCESS CHAIRS	Each	1	\$418.05	\$418.05
CRT3072FBLK2	CART 3072 FLAT BLK NM5 CART;HOLDS 3072 RECTANGULAR TABLE;FLAT;; BLK FRAME;NON MARRING 5" CASTERS Freight Estimate	Each	1	\$362.25	\$362.25
			1	\$3,117.42	\$3,117.42
				Subtotal	\$32,847.64
				Sales Tax	\$0.00
				Quote Total	<u>\$32,847.64</u>

BuyBoard contract # 789-25

(Lift gate \$410.00, if needed, not included)

Signature: _____

Date: _____

*** NET Pricing Applied. * Quotes are valid for 30-days. * Delivery is Dock-to-Dock. * Sales Tax may be applicable and is subject to change at time of shipment.**

*** Customer is responsible for offloading order at delivery time unless otherwise prearranged.**

***Freight Quotes are estimates. The Freight charge on your order, will reflect the current freight cost the day the order is placed.**

** Mity, Inc. charges a 3% processing fee for all credit card payments.*

*** The quoted price does not include any unforeseen tariff costs. These costs, if applicable, will be added based on the current market rate at the time of order placement.**



MityLite Inc. P.O. BOX 732698, Dallas, TX, 75373-2698 US | PHONE 801-224-0589 ext 4200 FAX 801-224-6191

QUOTE ACKNOWLEDGEMENT

THIS IS NOT AN INVOICE



Created On: 12/12/2025

Sales Quote Number: SQ82083

Mity Customer Number: A0124410

Page: 2 Of 2

MITYLITE **holsag** **BERTOLINI**

Bill

To: City of Orange Beach
Pamela Davis
4480 Orange Beach Blvd
Orange Beach, AL 36561
United States

Sell

To: City of Orange Beach
Pamela Davis
4480 Orange Beach Blvd
Orange Beach, AL 36561
United States

Ship

To: City of Orange Beach
Pamela Davis
4480 Orange Beach Blvd
Orange Beach, AL 36561
United States

Ship Via	Payment Terms	Sales Person
ORIGIN, Freight Prepaid	Payment Terms Pending	Scott Bean

Item No.	Description	UOM	QTY	Unit Price	Total Price
----------	-------------	-----	-----	------------	-------------

Subtotal \$32,847.64

Sales Tax \$0.00

Quote Total \$32,847.64

THANK YOU FOR CHOOSING MITY!

Signature: _____

Date: _____

* NET Pricing Applied. * Quotes are valid for 30-days. * Delivery is Dock-to-Dock. * Sales Tax may be applicable and is subject to change at time of shipment.

* Customer is responsible for offloading order at delivery time unless otherwise prearranged.

*Freight Quotes are estimates. The Freight charge on your order, will reflect the current freight cost the day the order is placed.

* Mity, Inc. charges a 3% processing fee for all credit card payments.

* The quoted price does not include any unforeseen tariff costs. These costs, if applicable, will be added based on the current market rate at the time of order placement.



MityLite Inc. P.O. BOX 732698, Dallas, TX, 75373-2698 US | PHONE 801-224-0589 ext 4200 FAX 801-224-6191



**REGULAR CITY COUNCIL MEETING
DECEMBER 16, 2025**

Departments: Community Development

Description of Topic: Public hearing for an ordinance amending Ordinance No. 172, the Zoning Ordinance, Case No. 0903-PUD-25, AC Hotel Orange Beach PUD.

Background/Description: Shiv Sagar Hospitality LLC requests Preliminary and Final PUD Approval to rezone 1.8 beachfront acres from Multi-Family Residential High Density (RM-2) to Planned Unit Development (PUD) for the purpose of converting an existing building into a hotel with 100 lodging rooms. The property is located at 23370 Perdido Beach Boulevard.

Action Options/Recommendation: The Planning Commission held a public hearing and considered this application at its regular meeting on November 10, 2025, and gave the request a **favorable recommendation** (7-2).

Source of Funding (if applicable): NA

ATTACHMENTS:

1. 0903-PUD-25 AC Hotel Orange Beach - Staff Memo
2. 0903-PUD-25 AC Hotel Orange Beach - Parking Platform Information
3. 0903-PUD-25 AC Hotel Orange Beach - PC Action Letter
4. 0903-PUD-25 AC Hotel Orange Beach - Responses to Certified Notices
5. 0903-PUD-25 AC Hotel Orange Beach - Application
6. 0903-PUD-25 AC Hotel Orange Beach - By-Right Plan

7. 0903-PUD-25 AC Hotel Orange Beach - Complete Master Plan Submission



PLANNING & ZONING
COMMUNITY DEVELOPMENT DEPARTMENT
P.O. BOX 2432
ORANGE BEACH, ALABAMA 36561



**ORANGE BEACH CITY COUNCIL
MEETING – DECEMBER 16, 2025**

**Case No. 0903-PUD-25
AC Hotel Orange Beach PUD
Preliminary and Final PUD Approval**

Owner:
Shiv Sagar Hospitality LLC
Ken Patel
23370 Perdido Beach Blvd.
Orange Beach, AL 36561
(251) 747-1461
ken@anrgroup.com

Applicant:
Same

Property Address:
23370 Perdido Beach Blvd.

Tax Parcel:
05-66-06-13-3-001-104.000

PPIN:
3292

I. GENERAL INFORMATION

Request: Preliminary and Final PUD Approval

Shiv Sagar Hospitality LLC requests preliminary and final PUD approval to rezone 1.8 beachfront acres from Multi-Family Residential High Density (RM-2) to Planned Unit Development (PUD) for the purpose of converting an existing building into a hotel with 100 lodging rooms.

Planning Commission: The Planning Commission held a public hearing and considered this project at its regular meeting on November 10, 2025. There was one participant in the public hearing who expressed concerns about the rooftop bar, noise levels, and possible impacts to the Beach Music development to the west. The Planning Commission approved its motion for positive recommendation on a 7-2 vote. Therefore, this project moves forward to the City Council with a **favorable recommendation**.

Location: This property is a beachfront lot located at 23370 Perdido Beach Boulevard. The existing building was formerly the Romar Beach Baptist Church and was constructed in 2007. In 2021 and 2023, the property owner obtained PUD approval to convert the church into a hotel. Both PUDs have expired.

Present Zoning: RM-2 (Multi-Family Residential High Density)

Present Use: Vacant (former location of Romar Beach Baptist Church)

Future Land Use: Resort High Intensity
The purpose of this PUD is to convert the former church building into a hotel with 100 lodging rooms. Hotels are not permitted by right in RM-2 zoning, thus a rezoning to PUD is required. Hotels are a recommended land use in this land use designation on the Future Land Use Map.

Surrounding Land Use and Zoning: **North:** Village of Tannin commercial area, PUD (Planned Unit Development - Village of Tannin)
South: Gulf of America
East: The Oasis at Orange Beach Condominium, PUD (Planned Unit Development – Phoenix West II)
West: Beach Music duplexes, RM-2 (Multi-Family Residential High Density)

Special Districts: **Overlay Zoning:** Beach Overlay District
Neighborhood District: Beach Resort
Airport Zone: None
Flood Zone: X-Shaded, AO, VE-15

Nearby Streets: This property has frontage on Perdido Beach Boulevard.

Site History:

Date	Description
August 2004	Romar Beach Baptist Church submitted a request for site plan review to expand its building to include a ground floor picnic area, an auditorium expansion on the second floor, and a dormitory on the third floor. The applicant pulled the request prior to Planning Commission consideration. (Case No. 0905-SP-04)
May 2006	Board of Adjustment approved a variance to Section 4.03, Table 4.0302, Minimum Setbacks, to allow an encroachment into the required 20-foot west side setback for a proposed parking structure. (Case No. 0503-V-06)
November 2006	Planning Commission approved the site plan review to allow the Romar Beach Baptist Church to reconstruct its building after it was destroyed by Hurricane Ivan in September 2004. The new church consists of five floors with a two-level parking garage being located between the church and the street. (Case No. 1105-SP-06)
January 2007	City Council approved the rezoning of this property from RS-1 to RM-2. (Case No. 0101-RS-07)
August 2021	City Council approved the preliminary and final PUD to rezone 1.8 acres from RM-2 to PUD for the purpose of converting the former Romar Beach Baptist Church into a hotel with 76 lodging rooms. This PUD expired in 2022. (Case No. 0704-PUD-21)
February 2023	City Council approved the preliminary and final PUD to rezone 1.8 acres from RM-2 to PUD for the purpose of converting the existing building into a hotel with 76 lodging rooms. Permits were obtained, but the permits expired in 2025. (Case No. 1203-PUD-22)

II. COMPREHENSIVE PLAN REVIEW

Section 7.03 of the zoning ordinance states the purpose and intent of the PUD ordinance to have developments that promote the goals of the comprehensive plan, and no PUD shall be approved unless it is consistent with the goals of the comprehensive plan. The *City of Orange Beach Preservation and Growth Management Plan, 2020-2035* shows this property as part of the **Beach Resort District**. The proposed PUD complies with the mission of this district as follows:

Beach Resort

The City of Orange Beach seeks to continue to adhere to the Beach Overlay District requirements, increase pedestrian paths that encourage pedestrian traffic between developments, sustain and enhance commercial development and expand facilities at existing beach access points.

Project's Response

The proposed development of the AC by Marriot supports the mission of the Beach Overlay District by introducing high-quality lodging and dining that enhances curb appeal, property values, and the overall coastal character of Orange Beach. The repurpose of a vacant building into a desirable lodging facility, aligning with the City's goal of sustaining and enhancing commercial development while contributing to the vitality of the beachfront community.

III. PUD DESIGN STANDARDS

Section 7.03 of the zoning ordinance requires all PUDs to achieve one or more of the following design standard objectives. The applicant indicates that one of the 12 design standards will be met.

- **Superior development and redevelopment which is more desirable than that which would occur through strict application of the zoning code.** Project's Response: Under the existing zoning (RM-2), this property could be developed as a 17-story condominium with up to 77 units, resulting in significant vertical construction impacts. Instead, the proposed PUD repurposes the existing vacant building into a first-class hotel, eliminating those impacts while still bringing economic activity and community value. By adapting and enhancing the site through redevelopment rather than pursuing maximum density, the proposed PUD provides a more balanced, desirable, and context-sensitive outcome than would otherwise be permitted.

IV. PUD MASTER PLAN REVIEW

Section 7.04 of the zoning ordinance states that an approved PUD shall be considered a separate zoning district in which development plans, as approved, establish the specific restrictions and regulations customized to fit the type of plan proposed by which the development shall be governed. Restrictions may be greater or lesser than the ones otherwise imposed by the zoning ordinance and subdivision regulations to achieve a development with fits the comprehensive plan and PUD design standards.

1. **Density: The criteria for establishing an average density includes the land use plan for the area, existing surrounding density, density permitted by the existing zoning classification, adequacy of existing and proposed public facilities and services and site characteristics.**

Density must generally conform to the requirements as set out in Article 4 of this ordinance and conform to the Comprehensive Plan. (Section 7.04, A.)

This beachfront property contains 1.83 acres. This hotel will be an AC Hotel by Marriot and will have 100 lodging rooms. All lodging rooms will be less than 600 SF and will count as 0.50 units when it comes to density calculations. The maximum densities allowed are 42 units per acre and 84 lodging rooms per acre. The hotel will have densities of 27.3 units per acre and 54.6 lodging rooms per acre.

In the 2021 and 2023 PUD submissions, the property owner had proposed a hotel with 76 lodging rooms, equating to densities of 20.7 units per acre and 41.5 lodging rooms per acre.

Under the current zoning (RM-2), multi-family residential condominiums are permitted by right, but hotels are not. The by-right plan for this property shows a 17-story condominium with 76 units and a density of 42 units per acre. The applicant contends that the hotel will have less density than by-right because it will take two lodging rooms to equal one unit, and the 100-room hotel represents 50 units.

Description	Zoning Allowance	By-Right Scenario	Proposed PUD
Units	76	76	50
Unit Density	42 units/acre	42 units/acre	27.3 units/acre
Lodging Rooms	153	--	100
Lodging Room Density	84 rooms/acre	--	54.6 rooms/acre

The by-right scenario also shows 173 bedrooms and a gross floor area exceeding 242,000 SF. The hotel will have 100 lodging rooms and 184 beds in total. The total floor area with the existing and new floor area combined will be less than 70,100 SF.

- 2. Common Open Space: At least 20 percent of the area covered by a Final Development Plan shall be landscaped or provide common open space owned and operated by the owner/developer or dedicated to a homeowner association or similar group. (Section 7.04, B.)**

The hotel will be a commercial entity that will own and manage the building and all outside areas.

- 3. Access and Parking: All streets, thoroughfares and access ways shall be designed to effectively relate to the major thoroughfare plans of the City of Orange Beach. Adequate off-street parking shall generally conform to the off-street parking requirements set forth in Article 8 of the Zoning Ordinance unless otherwise approved. (Section 7.04, C.)**

The hotel will have 100 lodging rooms. All lodging rooms will be less than 600 SF. For rooms of this size, the parking regulations require 1.25 spaces per room.

Use	Unit of Measure	Parking Ratio	Parking Regular	Parking HC
Lodging Rooms (less than 600 SF)	100 rooms	1.25 spaces per room	120	5
Total Parking Spaces Required			125	

The hotel will provide 125 spaces. All parking will be located underneath the building and within the two-story parking structure in front of the building. The applicant indicates the existing

parking structure will be demolished and reconstructed for ease of construction and column realignment for parking. There will be no increase in the square footage of the existing and new parking structure.

Of the 125 spaces, 78 spaces will be located on the lower level, while 47 spaces will be on the upper level. On the lower level, there will be double stacker (ParkPlus Double Stacker), which is a hydraulic 2-post, 2-level cantilevered vehicle lift for parking cars one above another. The double stacker will have 13 spaces on the lower platform and 13 spaces on the upper platform, accounting for 26 total spaces. According to the specifications, each platform can handle up to 6,000 pounds, and the height of the double stacking unit is almost 10 feet.

All parking will be valet and will be managed by a third-party company, such as Parking Management Company, which handles such services at several of the applicant's properties in Louisiana and Alabama.

Location	Total Spaces	Standard	Compact	Handicapped	Stacked
Lower Level	78	46	1	5	26
Upper Level	47	17	30	0	0
Total	125	63	31	5	26

While the proposed parking layout meets the parking requirements, the applicant estimates that the hotel will operate at full capacity for 50 to 60 days per year, meaning that most of the year the available parking supply will exceed demand.

Other Parking Notes:

- There will be 31 compact spaces, equating to 25 percent of the parking provided. The zoning ordinance allows up to 25 percent of required and 100 percent of excess spaces to be compact.
- The hotel will have a rooftop bar that will be for hotel guests only and will not be open to the public. A notation has been provided on the plans.
- The hotel will have a strict policy on having unauthorized vehicles on the premises towed.
- On employee parking, the hotel will have the following policy:
 - (a) The hotel will have 3 full-time employees, with only one permitted to park onsite during the workday;
 - (b) All other employees will be required to park at an offsite location designated by management; and
 - (c) The referenced employees will be transported to and from the property free of charge via a shuttle service operated by the hotel.

4. Perimeter Requirements: The Planning Commission the City Council may impose the requirement that structures, buildings and streets located at the perimeter of the development be permanently screened to protect the privacy of the adjacent existing uses. (Section 7.04, D.)

For a multi-family residential and commercial project on this property, a 30-foot land use buffer would be required on the west side due to the duplex residential land use to the west. In 2006, the Board of Adjustment approved a variance allowing an encroachment into the 20-foot west side setback for a proposed two-story parking structure for the Romar Beach Baptist Church. Presently, there is 5 feet between the parking structure and west side lot line.

For the third, fourth and fifth levels of the existing building, the hotel will construct additional floor space to these levels that will be located above the parking structure. On each floor, the new construction area will cover 10,171 SF. In addition, an additional floor will be added to the rooftop for a bar area. The bar area will cover more than 6,000 SF. The hotel requests a deviation to Section 4.05 of the zoning ordinance to allow the new construction to have a west side setback of 20 feet to match the side setback of the existing building.

The landscape plan on this and previous submissions shows landscaping being installed on the west side. Since the hotel will not have a swimming pool, Beach Music has expressed concerns that hotel guests may trespass to use its swimming pools. The hotel will provide an architecturally compatible wall on the west side to provide a buffer between it and Beach Music.

- 5. **Signage:** The size, location, design and nature of signs, if any, and the intensity and direction of area floodlighting shall be detailed in the application and must generally conform to the sign regulations in Article 15, unless the massing and scale of the PUD would make additional or different requirements desirable. Signs must nonetheless fit the design character of the development. (Section 7.04, E.)

The hotel will have signage on the front (street side) and rear (beach side) facades. Each of these signs will have a sign area covering more than 30 SF. There will also be letters on the front façade above the second level of the parking structure. The lettering will have a sign area covering 22 SF. There will also be a freestanding sign positioned between the parking structure and Perdido Beach Boulevard. All signage will comply with the sign regulations.

- 6. **Height Limitation:** The criteria for establishing height limitations include the land use plan for the area, existing surrounding building heights, heights permitted by the existing zoning classification, adequacy of existing and proposed public facilities and services and site characteristics. Height limitations must generally conform to the requirements as set out in Article 4 of this ordinance and conform to the Comprehensive Plan as well as the architectural standards set out in Article 10. (Section 7.04, F.)

The hotel project will increase the building height from 5 to 6 floors with the addition of the rooftop bar. The overall height, however, will decrease from 90’4” to 82 feet with the removal of the church steeple.

Level /Floor	Use
Ground	Parking (78 spaces)
Second	Parking (47 spaces), Reception Area, Lobby Lounge, Library, Offices
Third	Lodging Rooms (30 rooms), Fitness Room, Media Salon
Fourth	Lodging Rooms (35 rooms)
Fifth	Lodging Rooms (35 rooms)
Sixth	Rooftop Bar

- 7. **Landscaping and Tree Protection:** The criteria for landscaping, removal of trees and protection of heritage trees should generally conform to the requirements of Article 16. (Section 7.04, G.)

Landscaping will cover 24 percent of the developable area north of the Coastal Construction Line. Most of the landscaping will be situated around the building, along the west lot line, and between the parking structure and the front lot line. The trees planted will be a combination of Wax Leaf Ligustrum, Southern Live Oak, and Sabal Palms.

As with the previous PUD approvals, the hotel requests a deviation to Section 4.03 of the zoning ordinance to eliminate the 5-foot landscaped area between the east driveway and the east side lot line. The purpose of the deviation is to increase the width of the east side driveway to 26 feet for emergency access.

V. DEVIATIONS FROM THE ZONING ORDINANCE AND SUBDIVISION REGULATIONS

1. This PUD proposes the following deviations to the zoning ordinance.

	Section	Description	Required	Proposed
1	Section 4.03	Minimum Setbacks	5 feet between vehicle use area and side lot line for landscape buffer.	No landscape buffer; increase driveway width to 26 feet for emergency access.
2	Section 4.05	Buffering between Uses	30 feet between multi-family residential and commercial projects and low-impact land uses on the west side.	20 feet for new additions to the upper levels so that it matches the west side setback of the existing building and maintaining the existing 5-foot setback for the parking structure.

VI. STAFF COMMENTS

1. The property owner obtained PUD approvals in 2021 and 2023 to refurbish the existing building into a 76-room hotel. Both PUD approvals expired. This application follows the previous requests but increases the number of rooms from 76 to 100.
2. This project will add floor area to the upper floors of the existing building and an additional floor to the top. The project will increase the floor area on these levels by 10,171 SF, more than doubling the floor area for these levels. Overall, the floor area for the building will increase from what is currently at 23,376 SF to 70,062 SF.

Level	Existing Area	New Area	Total Area
Ground	0	0	0
Second	5,844 SF	10,171 SF	16,015 SF
Third	5,844 SF	10,171 SF	16,015 SF
Fourth	5,844 SF	10,171 SF	16,015 SF
Fifth	5,844 SF	10,171 SF	16,015 SF
Sixth	0	6,002 SF	6,002 SF
Total	23,376 SF	46,686 SF	70,062 SF

3. The floor additions on the third, fourth, and fifth levels will cantilever 6 feet over the driveway on the east side, leaving 20 feet of air space for emergency vehicles. The Fire Department has indicated the cantilever presents no issues.
4. The landscape plan on this and previous submissions shows landscaping being installed on the west side. Since the hotel will not have a swimming pool, Beach Music has expressed concerns that hotel guests may trespass to use its swimming pools. The hotel will provide an architecturally compatible wall and landscaping on the west side to provide a buffer between it and Beach Music.
5. With the proposed stacked parking system on the lower level, staff has expressed concerns about possible impacts on Beach Music from vehicle headlights on the upper platform. In this area, the height of the wall between the two developments may need to be increased.
6. The project will not provide a pedestrian-oriented area and 8-foot-wide sidewalk along Perdido Beach Boulevard, as it is no longer required in the Beach Overlay District.
7. All exterior lighting must be wildlife friendly per the City’s Lighting Ordinance 2025-1498.

VII. CITY COUNCIL OPTIONS

1. **APPROVAL** of Preliminary PUD Zoning and Master Plan Approval to rezone 1.8 beachfront acres from Multi-Family Residential High Density (RM-2) to Planned Unit Development (PUD) for the purpose of converting an existing building into a hotel with 100 lodging rooms.
2. **APPROVAL WITH CONDITIONS** of Preliminary PUD Zoning and Master Plan Approval.
3. **DENIAL** of Preliminary PUD Zoning and Master Plan Approval

Conditions of Approval
<ol style="list-style-type: none"> 1. Providing concurrence from the Alabama Department of Transportation for improvements to the existing driveway on Perdido Beach Boulevard. 2. Providing sign details for the proposed freestanding sign in front of the parking structure. 3. The height of the buffer wall between this development and Beach Music may need to be increased near the location of the double stack parking system to alleviate any negative impacts on Beach Music. 4. All exterior lighting must be wildlife friendly per the City's lighting ordinance 2025-1498.

VIII. PICTURES, MAPS & PLANS

Site Pictures

Eagle View Aerial, Looking North (October 2024)



Eagle View Aerial, Looking South (October 2024)



Street View, Looking South (May 2024)



Aerial Map



Building Elevations (Color)

View facing Perdido Beach Boulevard



View facing the beach



View facing Perdido Beach Boulevard



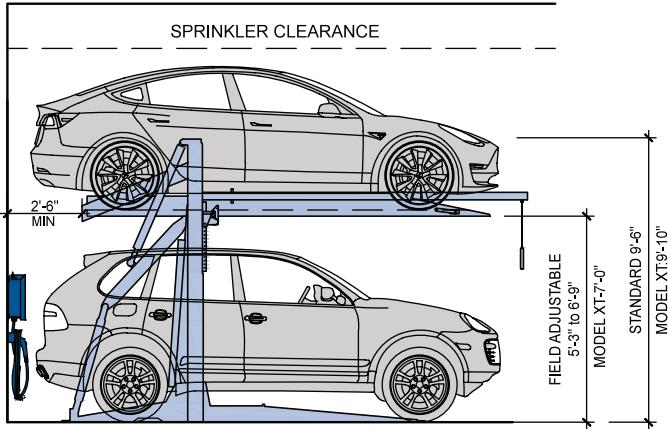

The **PARKPLUS DP003** Double Stacker is a hydraulic 2-post, 2-level cantilevered vehicle lift for parking cars one above another. The **DP003** raises and locks a platform in place so that a second vehicle can be parked at grade.

Entire assembly comes pre-welded and is assembled in the field. Stackers may be installed as single units or in arrays with shared common legs. Stacker is designed to be mounted on grade, concrete or asphalt. Approved foundation system may be required for installation of stackers.

The **PARKPLUS DP003** Double Stacker is designed to be installed indoors and outdoors. Platform height is field adjustable in 1 1/2" increments. Each city may have minimum height requirements and different clear requirements for code required parking. Owner/Architect should review with local planning and building departments. **MEP coordination with project team must meet code requirements and satisfy equipment clearances.**

Suitable For

- Standard passenger vehicles
- SUVs

Specifications

- Load per Platform:** 6,000 lbs.
- Weight of Unit:** +/- 3,050 lbs.
- Length of Platform:** 13'-6"
- Length incl. Overhang:** 16'-6"
- Width of Unit:** 7'-11" to 9'-0"
- Height of Unit:** 9'-6" to 9'-10"
- Operation:** Hydraulic
- Control:** Push Button Pendant

**Custom height and width available*

Power Pack

Hydraulic Power System (HPS)

- HPS1:** **1-2 units**
(208-230V / 1 PH / 60 HZ / 2-3 HP / 18 FLA)
- HPS-1P10:** **1-30 units**
(208-230V / 1 PH / 60 HZ / 10 HP / 40 FLA)
- HPS-3P10:** **1-30 units**
(208-230V / 3 PH / 60 HZ / 10 HP / 28.4 FLA)

Electrical

- 1 Disconnect required per HPS
- 3 PH 208-230V / 40Amp
- 1 PH 208-230V / 60Amp
- All control wiring is a Class 2 Circuit 24V*

Applications

DP003 Double Stacker can be installed in attended/valet and self-park applications:

- Single & Multi-Family Residential Buildings
- Indoor & Outdoor Installations
- Low & High Rise Buildings
- Commercial Buildings
- Surface Lots

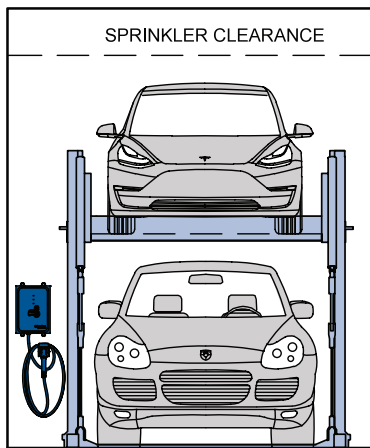

Clearance	
Model	Height
C/C	10'-6"
C/S	12'-2"
S/S	14'-0"
S/S*	14'-6"

C = Compact/Sedan
S = Standard/SUV
* LA City requirement

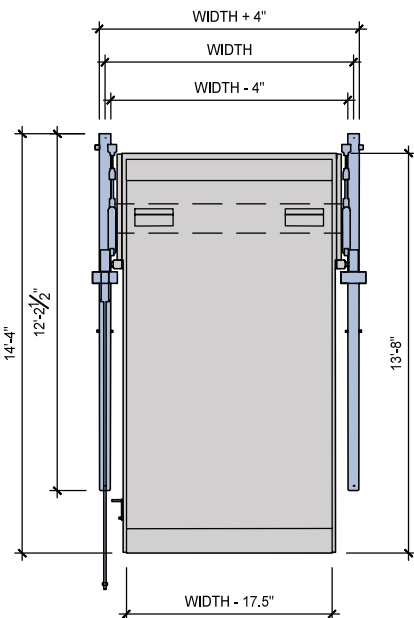

Width	
Model	Width
W01	7'-11"
W02	8'-3"
W03	8'-6"
W04	9'-0"
W05	Custom

WIDTH =
Center of Leg to Center of Leg

- ◇ IN-HOUSE DESIGN, MANUFACTURING, INSTALLATION & SERVICE
- ◇ MINIMAL MOVING PARTS – REDUCED MAINTENANCE

- ◇ GALVANIZED, COMMERCIAL-GRADE MACHINES
- ◇ PREMIUM QUALITY HYDRAULIC CYLINDERS

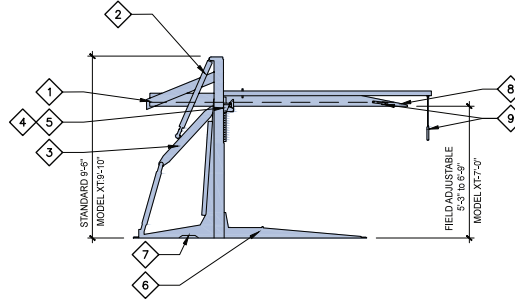
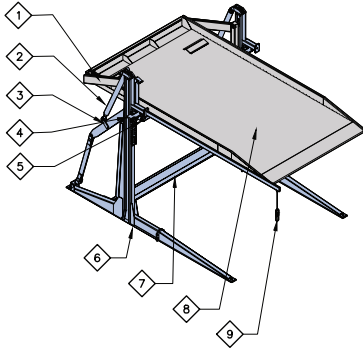

Components

- ① Cradle Frame Assembly
- ② Hydraulic Cylinder
- ③ Parallel Arm Assembly
- ④ Adjustable Height Assembly
- ⑤ Safety Locks Assembly
- ⑥ End Leg Assembly
- ⑦ Seismic Beam Assembly
- ⑧ Platform Assembly
- ⑨ Push Button Controls

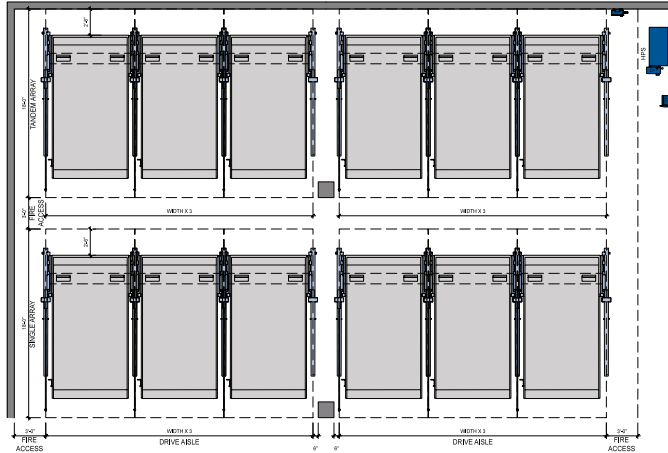

Layout

PARKPLUS DP003 Double Stacker can be arranged in single or tandem arrays on either side of a drive aisle. Queuing space of at least 2 vehicles must be provided to allow for shuffling of cars. Queuing space may be in drive aisle. For commercial projects, during peak traffic, all platforms will be lowered for quick filling of stackers. Surface space to be provided for code-required Accessible Parking.

ADDITIONAL INFORMATION

Safety

Device is equipped with safety locking system. 'Posi-lock' double suspension system holds full weight of vehicle on platform in locked position. Device can be equipped with individual keyed controller for extra safety. Self-attended applications may require additional sensors to detect objects located under platform or entering the area below platform.

Fire Protection

In most metropolitan areas, car stackers are reviewed as similar to high piled storage and non-building structures. Fire rating of structural components is not required. Sprinklers may be required per following section. Each city may have different fire department guidelines.

Fire Sprinklers

Outdoor: 1. Most cities do not require fire sprinklers. 2. May need to conform to additional zoning regulations and building code requirements.

Indoor: 1. Installation shall be in a sprinklered garage. In tandem array, additional sprinkler requirements may apply. 2. Sprinkler Plans filed and approved by local municipality. 3. Sprinkler system designed as required by NFPA 13 and local building codes. 4. Clear building height within parking area must accommodate height of equipment plus additional requirements for adequate coverage of fire sprinklers.

Temperature

Device is designed to operate between 20° and 120° F. For below freezing environments, hydraulic heaters for Power Packs are recommended.

Loading

Structural design and loading is provided on a project by project basis and is dependant on seismic zones, soil conditions and other environmental conditions.

Warranty

12-month Standard Manufacturer's Warranty on new equipment. Equipment Lifespan: Indoor = 7,500 cycles; Outdoor = 5,000 cycles.

Service

At end of 12-month warranty period a service contract is available upon request. Rental option may include Service & Maintenance for full term.

Approvals

- MEA/OTCR Certified, City of New York
- LAETL Approved, LARR#930501, City of Los Angeles
- California Seismic Code Compliant
- Miami Dade County Compliant
- Approved in multiple U.S. Cities

TURNKEY PROJECT SOLUTIONS

PARKPLUS is the leading provider of high density parking systems, with the most completed projects, and the most extensive product range, in the United States. **PARKPLUS** was established over 50 years ago, our experience is based on a multitude of projects spanning over half a century.

To ensure the highest quality in our parking solutions, **PARKPLUS** provides complete service across every project. We employ professional full-time staff dedicated to **Design & Engineering, Assembly & Installations, Procurement & Manufacturing, and Service & Support.**

HIGH DENSITY PARKING SYSTEMS



Automated Systems
Advanced technologies for robotic parking solutions

Mechanical Stackers
Attended systems for multi-level basic stacking

Custom Solutions
Creative solutions for custom design & exposure

OUR USA PROJECT FOOTPRINT

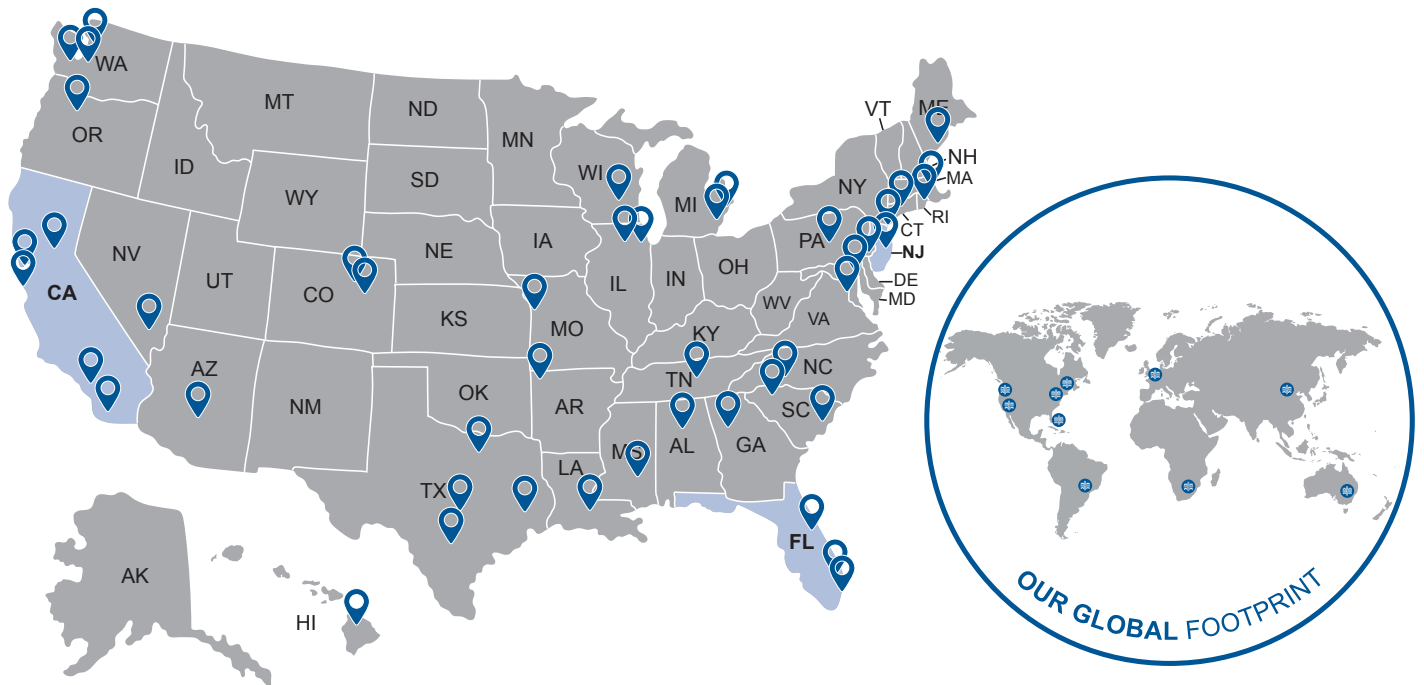

PARKPLUSINC.COM
INFO@PARKPLUSINC.COM

☎ +1 (844) 472 7575 / 8 444 PARKPLUS

PARKPLUS, INC. HEADQUARTERS
160 E UNION AVENUE,
EAST RUTHERFORD, NJ 07073

☎ +1 (201) 917 5778

PARKPLUS CALIFORNIA
8640 TAMARACK AVENUE, LOS
ANGELES, CA 91352. **CSLB# 1018794**

☎ +1 (800) 459 2604

PARKPLUS FLORIDA, INC.
1111 OLD GRIFFIN ROAD
DANIA BEACH, FL 33004

☎ +1 (954) 929 7511



PLANNING & ZONING
COMMUNITY DEVELOPMENT DEPARTMENT
P.O. BOX 2432
ORANGE BEACH, ALABAMA 36561



VIA EMAIL - ken@anrgroup.com

November 17, 2025

Ken Patel
Shiv Sagar Hospitality LLC
23370 Perdido Beach Boulevard
Orange Beach, AL 36561

**RE: Planning Commission Action Letter
Preliminary and Final PUD Approval
Case No. 0903-PUD-25, AC Hotel Orange Beach PUD**

Dear Mr. Patel,

On November 10, 2025, the Orange Beach Planning Commission held a public hearing and considered the above referenced application. The motion for favorable recommendation was approved. Therefore, this application will go forward to the City Council with a **positive recommendation** subject to the following conditions:

1. Approval of the requested deviations to Sections 4.03 and 4.05 of the zoning ordinance.
2. Providing concurrence from the Alabama Department of Transportation for improvements to the existing driveway on Perdido Beach Boulevard.
3. Providing sign details for the proposed freestanding sign in front of the parking structure.
4. The height of the buffer wall between this development and Beach Music may need to be increased near the location of the double stack parking system to alleviate any negative impacts on Beach Music.
5. All exterior lighting must be wildlife friendly per the City's lighting ordinance 2025-1498.

Staff will place this application on the City Council's Committee of the Whole agenda on November 18, 2025, to set the date for the public hearing and first reading. The tentative date for the public hearing and first reading will be December 16, 2025, at 5:00 p.m.

Please contact our office if you have any questions.

Regards,

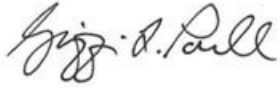
A handwritten signature in black ink, appearing to read "Griffin L. Powell". The signature is written in a cursive style with a large initial "G".

Griffin L. Powell
City Planner

Cc: Sean Brumley, GIS Specialist
Sherri Descalzo, Planning Coordinator
Zach Hoyt, A&R Group
Chris Pappas, City Engineer
Adam Roberson, CDD Director/Building Official

Notice of Public Hearing
October 13, 2025- 4:00 P.M.
Orange Beach Municipal Complex – Council Chambers
4099 Orange Beach Blvd.

Case No. 0903-PUD-25, AC Hotel Orange Beach PUD

Shiv Sagar Hospitality LLC requests recommendation to the City Council for Preliminary and Final PUD Approval to rezone 1.8 beachfront acres from Multi-Family Residential High Density (RM-2) to Planned Unit Development (PUD) for the purpose of converting an existing building into a hotel with 100 lodging rooms. The property is located at 23370 Perdido Beach Boulevard. Deferred from the Regular Meeting on September 8, 2025.

Please provide the following information and mail back to the City of Orange Beach if you plan to attend the public hearing on this matter. This information will enable the City to inform you if, for any reason, the public hearing on this matter is postponed or cancelled. It is very important that this form be returned if you are planning to attend as it could save you an unnecessary trip if the hearing is cancelled or if this item is removed from the agenda.

If you cannot attend the meeting but wish to submit your comments, please use the space below. You may email your form or comments to sdescalzo@orangebeachal.gov

Name: Bill Feid

Mailing Address: 3A market st Orange Beach AL 36561

City, State, Zip: _____

Day Phone (415) 336 6894

Please return this form to:

Sherri Descalzo
Orange Beach Planning Commission
P.O. Box 2432
Orange Beach, AL 36561
(251) 981-6794
Email: sdescalzo@orangebeachal.gov

Comments:



DEVELOPMENT PERMIT APPLICATION

To be completed by Community Development Department Staff

APPLICATION DATA

Application #: 0903-PUD25

Total Fees Paid: 1500.00

Check Number: 1112

TYPE OF APPLICATION

- Administrative Site Plan Review
- Site Plan Review
- Preliminary/Final Minor Subdivision Approval
- Preliminary Major Subdivision Approval
- Final Major Subdivision Approval
- Rezoning
- Preliminary PUD Approval
- Final PUD Approval
- PUD Modification
- Temporary Portable Building

RECEIVED

JUL 31 2025

O.B. COMMUNITY DEV.

NAME OF PROJECT: AC Hotel Orange Beach, AL

PROJECT DESCRIPTION: *(Provide Brief Description of Proposed Development, Subdivision, Rezoning, Portable Building, or Special Event; To include lot sizes, square footage of building coverage, number of lots, proposed land uses, number of units, number of buildings, a project narrative, etc.; if more space is needed attach a separate page)*

Rezoning from RM-2 to PUD

100-Room Hotel

PROPERTY INFORMATION:

Address: 23370 Perdido Beach Blvd Tax Parcel #(s): 66-06-13-3-001-104.000
Orange Beach, AL 36561

Existing Use: Vacant Building Zoning: RM-2 PPIN #(s) 003292

APPLICANT INFORMATION:

Name: Shiv Sagar Hospitality LLC Contact Person: Virendra (Ken) Patel

Address: 23370 Perdido Beach, Boulevard, Orange Beach, AL 36561

Phone #: (251) 747-1461 Fax #: () Email: ken@anrgroup.com

OWNER INFORMATION:

Name: Shiv Sagar Hospitality LLC Contact Person: Virendra (Ken) Patel

Address: 23370 Perdido Beach Boulevard, Orange Beach, AL 36561

Phone #: (251) 747 - 1461 Fax #: () Email: ken@anrgroup.com

Signature (Applicant): Date: 7/29/25

Signature (Owner): Date: 7/29/25



1 FRONT RENDERING
SCALE: NTS



2 REAR RENDERING
SCALE: NTS

ALL DRAWINGS, SPECIFICATIONS, PLANS, IDEAS, ARRANGEMENTS AND DESIGNS REPRESENTED OR REFERRED TO ARE THE PROPERTY OF JCER DESIGN CONSULTANTS, WHETHER THE PROJECT FOR WHICH THEY ARE PREPARED IS EXECUTED OR NOT. THEY ARE CREATED, EVOLVED, DEVELOPED AND PRODUCED SOLELY FOR USE ON AND IN CONNECTION WITH THIS PROJECT AND MAY NOT BE DISCLOSED OR GIVEN TO OR USED BY ANY PERSON, FIRM OR CORPORATION FOR ANY USE OR PURPOSE WHATSOEVER, EXCEPT UPON WRITTEN PERMISSION AND DIRECTION OF JCER DESIGN CONSULTANTS.

OWNER

OWNER NAME
A&R DEVELOPMENT
GULF SHORES, AL

PROJECT TEAM

CIVIL ENGINEER
Engineering Design Group
DAVID DICHAHA
DICHAHA@EDGALABAMA.COM

REVISIONS

PUD REVIEW	09.29.2025
PUD REVIEW	10.27.2025

PROJECT NAME

AC RETREAT, BY MARRIOTT
ROMAR BEACH, AL

DRAWING NAME

FRONT AND REAR RENDERING

SEAL + SIGNATURE

DATE 09.29.2025

PROJECT NUMBER 22.200

DRAWING NUMBER

A-100.00

PAGE NUMBER

© JCER Design Consultants 2025



1 FRONT RENDERING
SCALE: NTS

J C E R DESIGN
 J C E R DESIGN CONSULTANTS LLC
 NEW YORK
 325 GOLD STREET STE 604
 BROOKLYN, NY 11201

ALL DRAWINGS, SPECIFICATIONS, PLANS, IDEAS, ARRANGEMENTS AND DESIGNS REPRESENTED OR REFERRED TO ARE THE PROPERTY OF J C E R DESIGN CONSULTANTS. WHETHER THE PROJECT FOR WHICH THEY ARE PREPARED IS EXCLUDED OR NOT, THEY ARE CREATED, EVOLVED, DEVELOPED AND PRODUCED SOLELY FOR USE ON AND IN CONNECTION WITH THIS PROJECT AND MAY NOT BE DISCLOSED OR GIVEN TO OR USED BY ANY PERSON, FIRM OR CORPORATION FOR ANY USE OR PURPOSE WHATSOEVER, EXCEPT UPON WRITTEN PERMISSION AND DIRECTION OF J C E R DESIGN CONSULTANTS.

OWNER

OWNER NAME
 ASR DEVELOPMENT
 GULF SHORES, AL

PROJECT TEAM

CIVIL ENGINEER
 Engineering Design Group
 DAVID DICHARA
 DICHARA@EDGALABAMA.COM

REVISIONS

	PLD REVIEW	09.29.2025
	PLD REVIEW	10.27.2025

PROJECT NAME

AC RETREAT, BY MARRIOTT
 ROMAR BEACH, AL

DRAWING NAME

FRONT RENDERING

SEAL+SIGNATURE DATE 09.29.2025

PROJECT NUMBER 22.200

DRAWING NUMBER

A-101.00

PAGE NUMBER

© J C E R Design Consultants 2025

ALL DRAWINGS, SPECIFICATIONS, PLANS, IDEAS, ARRANGEMENTS AND DESIGNS REPRESENTED OR REFERRED TO ARE THE PROPERTY OF JCR DESIGN CONSULTANTS WHETHER THE PROJECT FOR WHICH THEY ARE PREPARED IS EXECUTED OR NOT. THEY ARE CREATED, EVOLVED, DEVELOPED AND PRODUCED SOLELY FOR USE ON AND IN CONNECTION WITH THIS PROJECT AND MAY NOT BE DISCLOSED OR GIVEN TO OR USED BY ANY PERSON, FIRM OR CORPORATION FOR ANY USE OR PURPOSE WHATSOEVER, EXCEPT UPON WRITTEN PERMISSION AND DIRECTION OF JCR DESIGN CONSULTANTS.

OWNER
 OWNER NAME
 ASR DEVELOPMENT
 GULF SHORES, AL

PROJECT TEAM
 CIVIL ENGINEER
 Engineering Design Group
 DAVID DICHIARA
 DICHIARA@GALABAMA.COM

REVISIONS		
	RJD REVIEW	09.29.2025
	RJD REVIEW	10.27.2025

PROJECT NAME
 AC RETREAT, BY MARRIOTT
 ROMAR BEACH, AL

DRAWING NAME
 FIRST AND SECOND FLOOR
 PLAN

SEAL-SIGNATURE	DATE	09.29.2025
	PROJECT NUMBER	22.200
	DRAWING NUMBER	A-102.00
	PAGE NUMBER	
© JCR Design Consultants 2025		

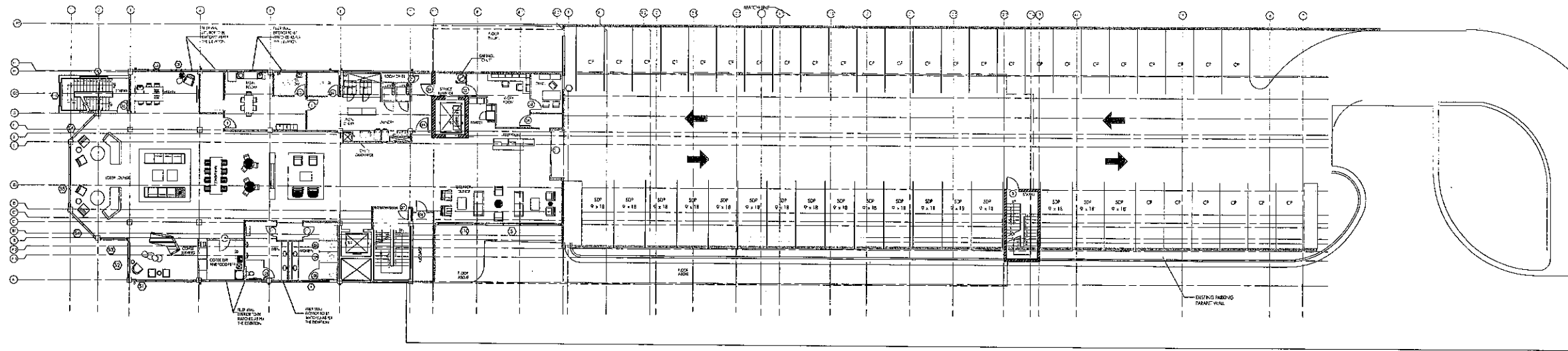

2 SECOND FLOOR PLAN
 SCALE: 1/16"=1'-0"

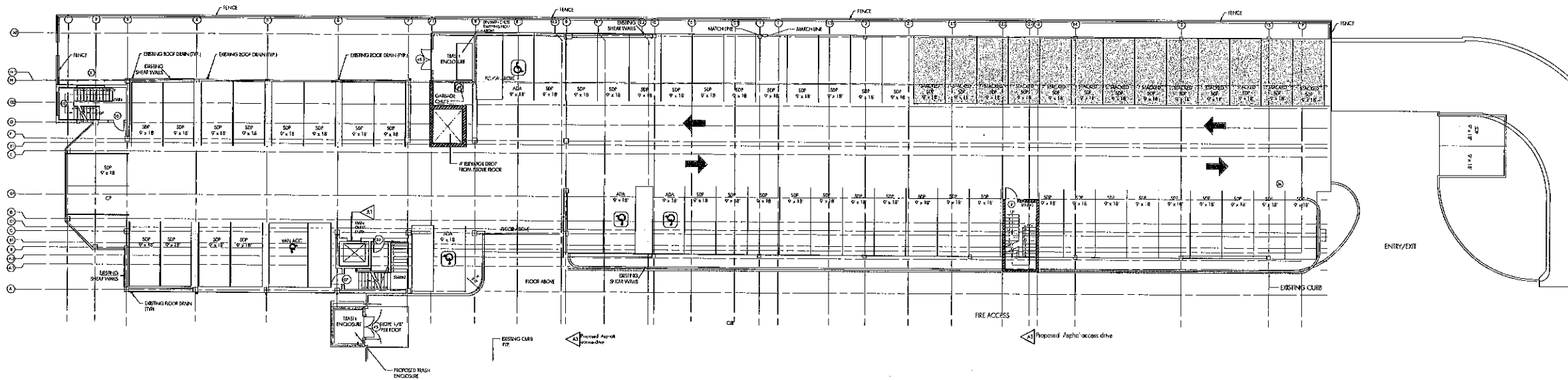

1 FIRST FLOOR PLAN
 SCALE: 1/16"=1'-0"

ALL DRAWINGS, SPECIFICATIONS, PLANS, IDEAS, ARRANGEMENTS AND DESIGNS REPRESENTED OR REFERRED TO ARE THE PROPERTY OF JCER DESIGN CONSULTANTS WHETHER THE PROJECT FOR WHICH THEY ARE PREPARED IS EXECUTED OR NOT. THEY ARE CREATED, EVOLVED, DEVELOPED AND PRODUCED SOLELY FOR USE ON AND IN CONNECTION WITH THIS PROJECT AND MAY NOT BE DISCLOSED OR GIVEN TO OR USED BY ANY PERSON, FIRM OR CORPORATION FOR ANY USE OR PURPOSE WHATSOEVER, EXCEPT UPON WRITTEN PERMISSION AND DIRECTION OF JCER DESIGN CONSULTANTS

OWNER
OWNER NAME
A&R DEVELOPMENT
GULF SHORES, AL

PROJECT TEAM
CIVIL ENGINEER
Engineering Design Group
DAVID DICHABA
DICHABED@GULFARABAMA.COM

REVISIONS		
	RUD REVIEW	09.29.2025
	RUD REVIEW	10.27.2025

PROJECT NAME
AC RETREAT, BY MARRIOTT
ROMAR BEACH, AL

DRAWING NAME
THIRD FLOOR PLAN
TYPICAL FLOOR PLAN

SEAL+SIGNATURE	DATE	09.29.2025
	PROJECT NUMBER	22.200
	DRAWING NUMBER	A-103.00
	PAGE NUMBER	
	© JCER Design Consultants 2025	

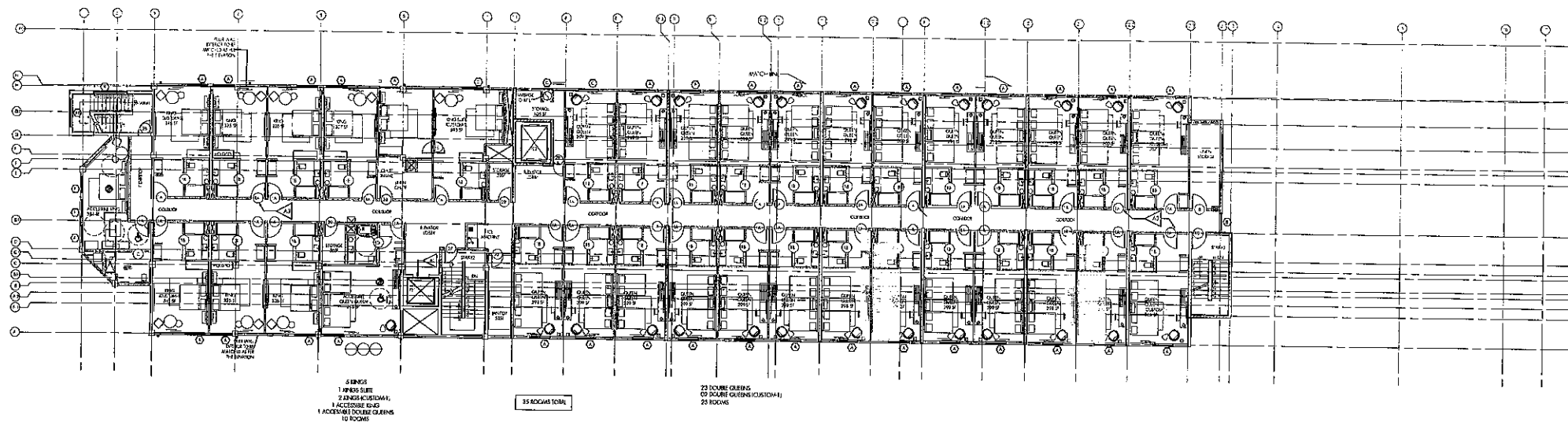

2 FOURTH AND FIFTH FLOOR PLAN
SCALE: 1/16"=1'-0"

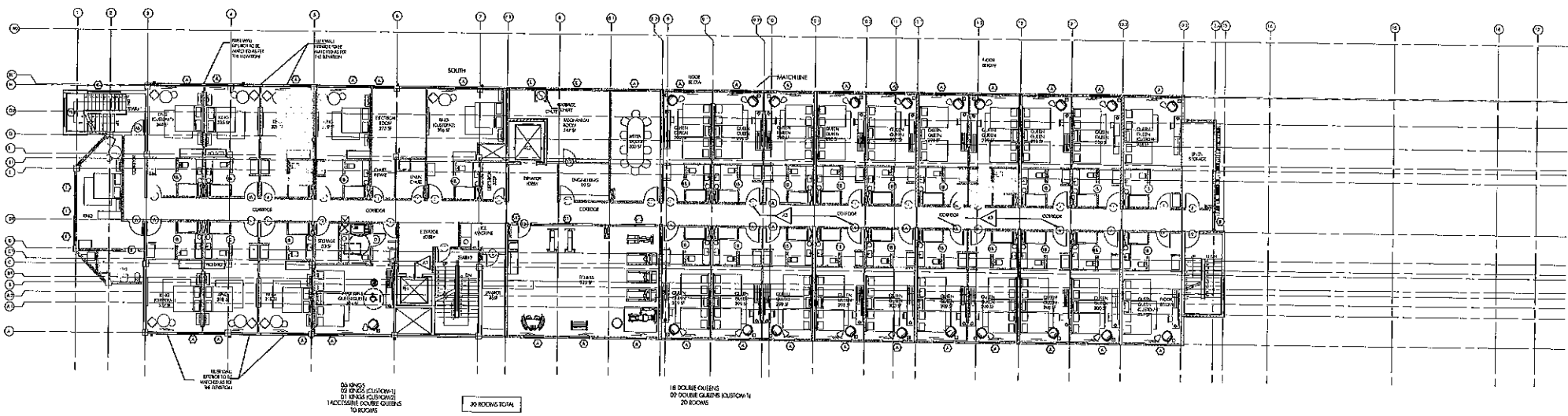

1 THIRD FLOOR PLAN
SCALE: 1/16"=1'-0"

ALL DRAWINGS, SPECIFICATIONS, PLANS, IDEAS, ARRANGEMENTS AND DESIGNS REPRESENTED OR REFERRED TO ARE THE PROPERTY OF JCEER DESIGN CONSULTANTS. WHETHER THE PROJECT FOR WHICH THEY ARE PREPARED IS EXECUTED OR NOT, THEY ARE CREATED, EVOLVED, DEVELOPED AND PRODUCED SOLELY FOR USE ON AND IN CONNECTION WITH THIS PROJECT AND MAY NOT BE DISCLOSED OR GIVEN TO OR USED BY ANY PERSON, FIRM OR CORPORATION FOR ANY USE OR PURPOSE WHATSOEVER EXCEPT UPON WRITTEN PERMISSION AND DIRECTION OF JCEER DESIGN CONSULTANTS.

OWNER

OWNER NAME
A&R DEVELOPMENT
GULF SHORES, AL

PROJECT TEAM
CIVIL ENGINEER
Engineering Design Group
DAVID DICHA
DICHA@JCEERDESIGN.COM

REVISIONS		
	RUD REVIEW	09.29.2025
	RUD REVIEW	10.27.2025

PROJECT NAME
AC RETREAT, BY MARRIOTT
ROMAR BEACH, AL

DRAWING NAME
ROOF PLAN AND PROJECT
MATRIX

SEAL + SIGNATURE	DATE	09.29.2025
	PROJECT NUMBER	22.200
	DRAWING NUMBER	A-104.00
	PAGE NUMBER	
© JCEER Design Consultants, 2025		

PROJECT MATRIX

ROOM MATRIX	FLOOR					TOTAL	
	1	2	3	4	5		
GUESTROOMS							
STANDARD KING		9	7	7		23	25%
ACCESSIBLE KING *		0	1	1		2	
STANDARD QUEEN/QUEEN		20	25	29		70	73%
ACCESSIBLE QUEEN/QUEEN *		1	1	1		3	
KING SUITE						2	3%
TOTAL		30	35	35		100	100
ACCESSIBLE ROOMS *						5	8%

	FLOOR AREA (SF)		
	EXISTING	EXISTING + NEW CONSTRUCTION	NEW CONSTRUCTION
1ST LEVEL PLAN (PODIUM)	-	-	-
2ND LEVEL PLAN (FCH + BOH + PARKING)	5,844 SF	16,015 SF	10,171 SF
3RD LEVEL FLOOR PLAN	5,844 SF	16,015 SF	10,171 SF
4TH LEVEL FLOOR PLAN	5,844 SF	16,015 SF	10,171 SF
5TH LEVEL FLOOR PLAN	5,844 SF	16,015 SF	10,171 SF
ROOF TOP LEVEL FLOOR PLAN	-	6,002 SF	6,002 SF
TOTAL	23,376 SF	70,062 SF	46,886 SF

PARKING TYPE	PARKINGS MATRIX	
	REQUIRED	PROVIDED
ACCESS. PARKING SPACE	5	5
VAN PARKING SPACE	1 INCLUDED IN 5 REQUIRED	1 INCLUDED IN 5 REQUIRED
STANDARD PARKING SPACE	89 TOTAL REQ'D	89
COMPACT PARKING SPACE	25% MAX ALLOWED INCLUDED IN TOTAL REQ'D	31
TOTAL PARKING SPACES	125	125

NOTE: 100 ROOMS X 1.25 PARKING SPACES = 125 PARKING SPACES REQUIRED. EMPLOYEE PARKING (1) X 0.33 = 0.33 SPACES. TOTAL REQUIRED PARKING SPACES = 125 SPACES. TOTAL PROVIDED = 125.

NOTE: ONLY (1) ONE EMPLOYEE WILL BE PERMITTED TO PARK ON-SITE. ALL OTHER EMPLOYEES WILL BE SHUTTLED FROM AN OFF-SITE LOCATION

NOTE: NO SELF PARKING. 100% VALET PARKING ONLY.

NOTE: BED COUNT INFORMATION SHOWN IN THIS TABLE IS PROVIDED FOR INFORMATIONAL PURPOSES ONLY. BED COUNT MAY BE MODIFIED AT OWNER DISCRETION AS NEEDED; SO LONG AS THE ROOM COUNT DOES NOT EXCEED THE TOTAL LISTED IN THIS TABLE.

NOTE: ROOFTOP BAR FOR HOTEL GUESTS ONLY.

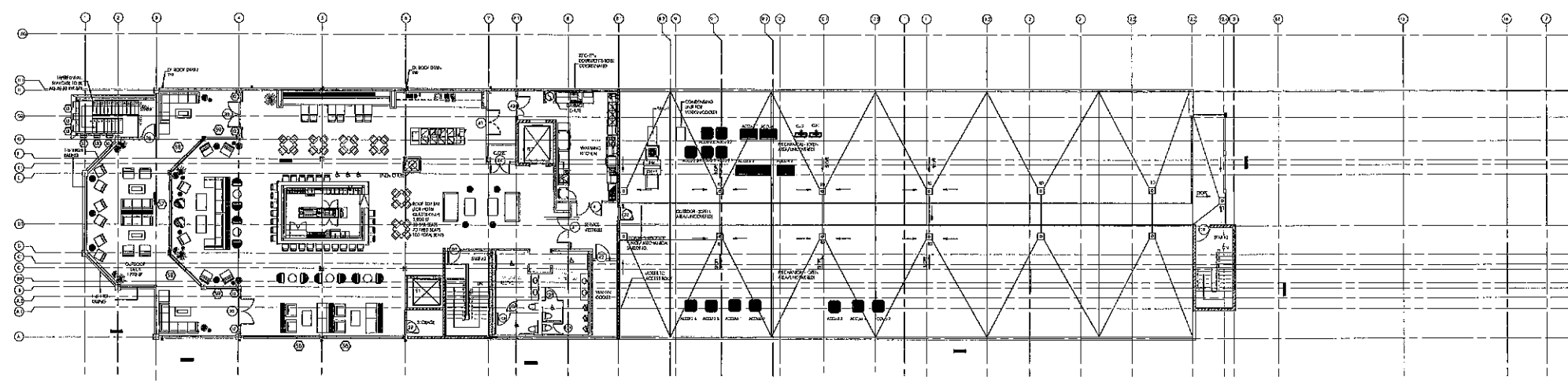

1 ROOF PLAN
SCALE: 1/16"=1'-0"

ALL DRAWINGS, SPECIFICATIONS, PLANS, IDEAS, ARRANGEMENTS AND DESIGNS REPRESENTED OR REFERRED TO ARE THE PROPERTY OF JCER DESIGN CONSULTANTS. WHETHER THE PROJECT FOR WHICH THEY ARE PREPARED IS ESCORTED OR NOT, THEY ARE CREATED, EVOLVED, DEVELOPED AND PRODUCED SOLELY FOR USE ON AND IN CONNECTION WITH THIS PROJECT AND MAY NOT BE DISCLOSED OR GIVEN TO OR USED BY ANY PERSON, FIRM OR CORPORATION FOR ANY USE OR PURPOSE WHATSOEVER, EXCEPT UPON WRITTEN PERMISSION AND DIRECTION OF JCER DESIGN CONSULTANTS.

OWNER
OWNER NAME
A&R DEVELOPMENT
GUY SHORES, AL

PROJECT TEAM
CIVIL ENGINEER
Engineering Design Group
DAVID DICHIARA
DICHIARA@JCDGALABAMA.COM

REVISIONS		
	RUD REVIEW	09.29.2025
	RUD REVIEW	10.27.2025

PROJECT NAME
AC RETREAT, BY MARRIOTT
ROMAR BEACH, AL

DRAWING NAME
EAST AND WEST ELEVATIONS

SEAL & SIGNATURE	DATE	09.29.2025
	PROJECT NUMBER	22.200
	DRAWING NUMBER	A-105.00
	PAGE NUMBER	
	©JCER Design Consultants 2025	

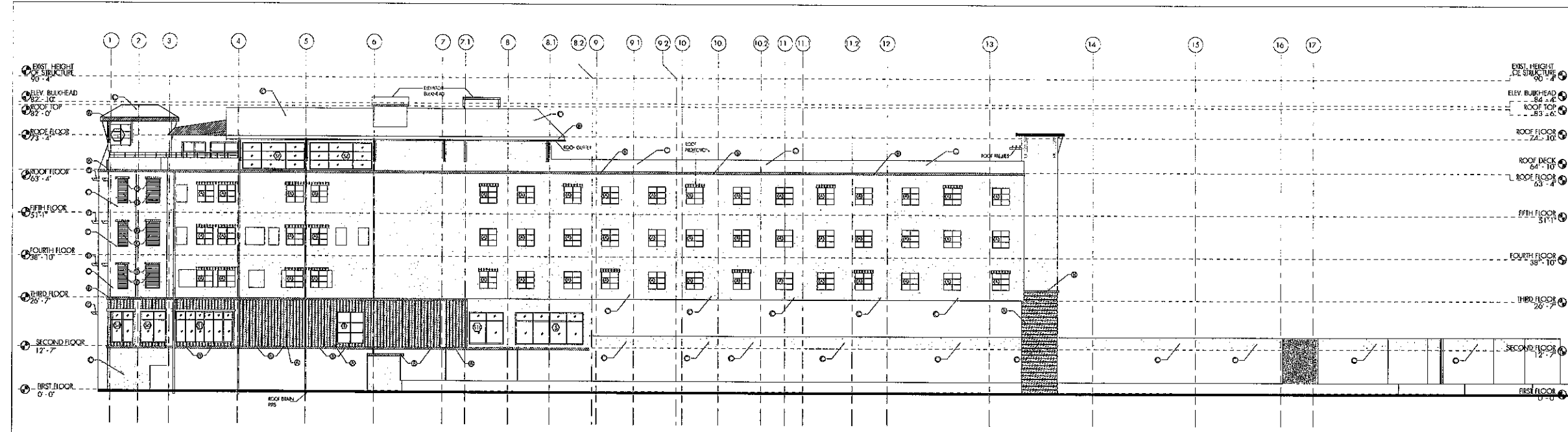

2 EAST ELEVATION
SCALE: 1/16"=1'-0"

MATERIAL LEGEND

	EXTERIOR CLADDING EXTERIOR OF WOOD
	COLOR: PURE WHITE 2002 SHERWIN WILLIAMS
	COLOR: SNOW WHITE 2042 SHERWIN WILLIAMS
	COLOR: WHITE WOODEN TEROCCA
	COLOR: CLEAR ANODIZED ALUMINUM

NOTE: CONSULTOR TO VERIFY THE COLOR AND MATERIAL WITH ARCHITECT BEFORE DECISION

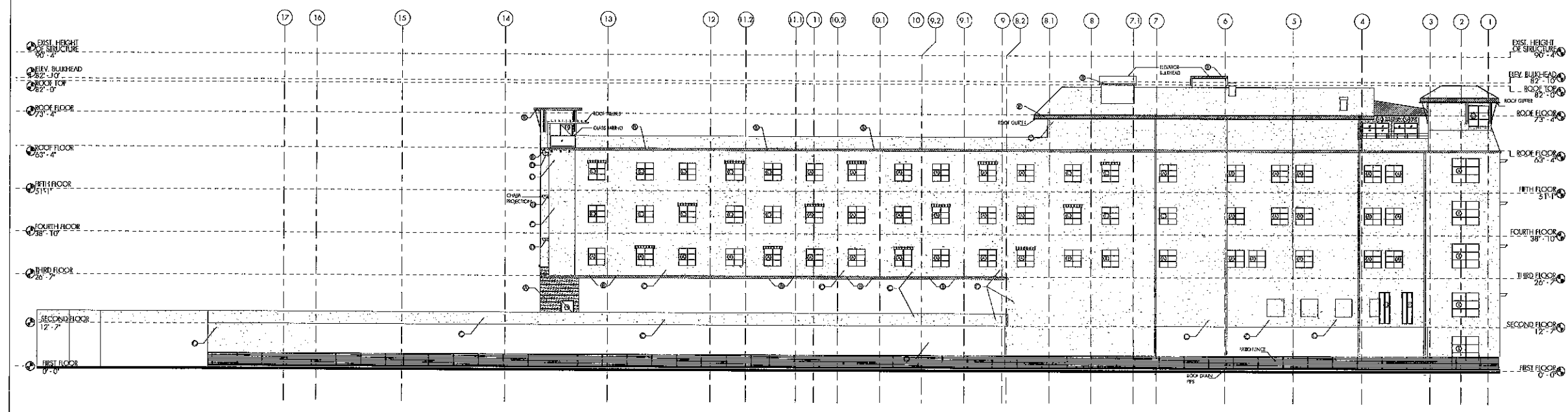

1 WEST ELEVATION
SCALE: 1/16"=1'-0"

ALL DRAWINGS, SPECIFICATIONS, PLANS, IDEAS, ARRANGEMENTS AND DESIGNS REPRESENTED OR REFERRED TO ARE THE PROPERTY OF JCER DESIGN CONSULTANTS WHETHER THE PROJECT FOR WHICH THEY ARE PREPARED IS EXECUTED OR NOT. THEY ARE CREATED, EVOLVED, DEVELOPED AND PRODUCED SOLELY FOR USE ON AND IN CONNECTION WITH THIS PROJECT AND MAY NOT BE DISCLOSED OR GIVEN TO OR USED BY ANY PERSON, FIRM OR CORPORATION FOR ANY USE OR PURPOSE WHATSOEVER, EXCEPT UPON WRITTEN PERMISSION AND DIRECTION OF JCER DESIGN CONSULTANTS.

OWNER:
 A&R DEVELOPMENT
 GULF SHORES, AL

PROJECT TEAM
 CIVIL ENGINEER
 Engineering Design Group
 DAVID DICHA
 DICHA@MEDGALABAMA.COM
 STRUCTURAL CONSULTANT
 KCE Consulting Engineers, PLLC
 325 Gold Street, Suite 604
 New York, NY 11201
 T 347.778.5908

MEP ENGINEER
 MEP Green Design & Build
 17047 El Comino Road, Suite 211
 Houston, TX 77058
 T 832.276.0252

REVISIONS		
	DOB SUBMISSION	09-12-2023
	DOB SUBMISSION	05-07-2024
	DOB SUBMISSION	05-13-2024
	DOB SUBMISSION	07-18-2024
	DOB SUBMISSION	07-25-2024
	DOB SUBMISSION	10-27-2025

PROJECT NAME
AC HOTEL, BY MARRIOTT
ORANGE BEACH, AL

DRAWING NAME

FENCE ELEVATION & DETAIL

SEAL-SIGNATURE	DATE	07.25.2024
	PROJECT NUMBER	22.200
	DRAWING NUMBER	B412
	PAGE NUMBER	112 - 131
©JCER Design Consultants 2023		

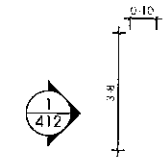

5 PATIO GATE PLAN
 SCALE: 3/8" = 1'-0"



3 PATIO FENCEPLAN PLAN
 SCALE: 1/4" = 1'-0"

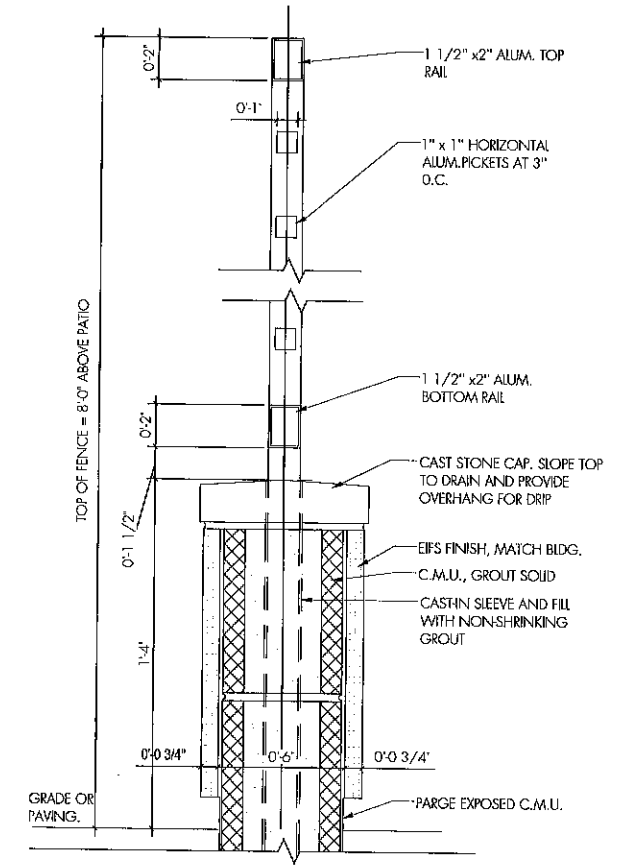

4 PATIO FENCE DETAIL
 SCALE: 3" = 1'-0"

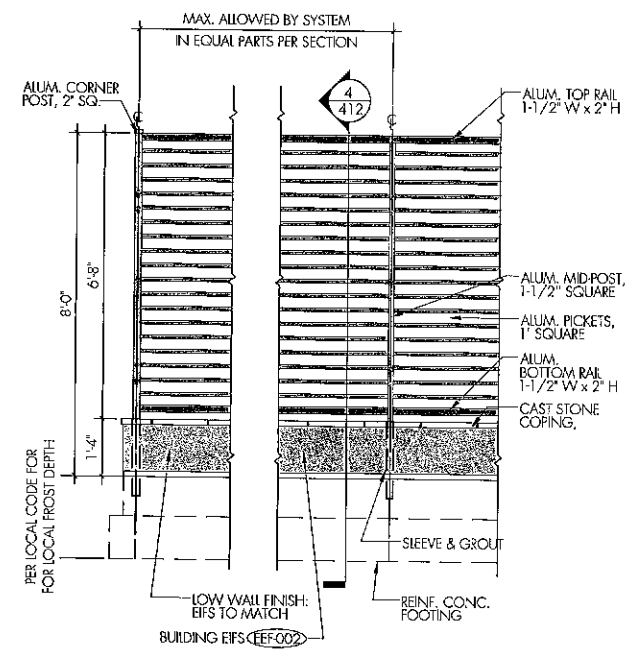

2 PATIO FENCE ELEVATION
 SCALE: 1/2" = 1'-0"

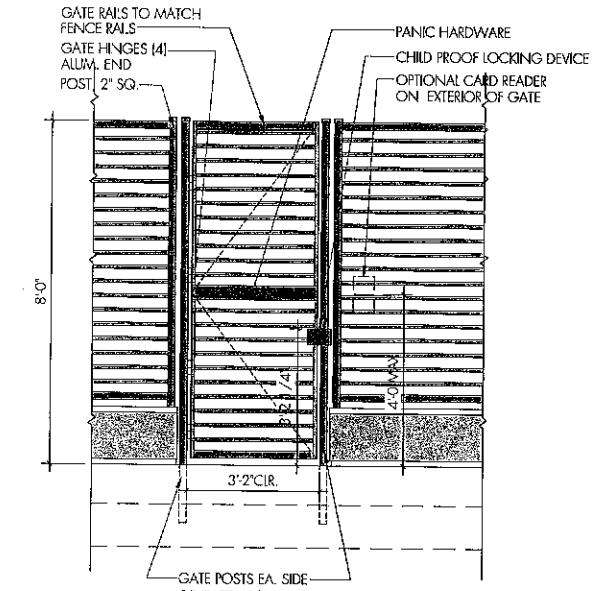

1 PATIO GATE ELEVATION
 SCALE: 1/2" = 1'-0"



**REGULAR CITY COUNCIL MEETING
DECEMBER 16, 2025**

Departments: City Clerk

Description of Topic: First Reading - Ordinance amending Ordinance No. 172, the Zoning Ordinance, Case No. 0903-PUD-25, AC Hotel Orange Beach PUD.

Background/Description:

Action Options/Recommendation:

Source of Funding (if applicable):

ATTACHMENTS:

1. 2025-xxxx Amd 172 0903-PUD-25 AC Hotel Orange Beach

ORDINANCE NO. 2025-xxxx

**AN ORDINANCE FURTHER AMENDING ORDINANCE NO. 172,
CITY OF ORANGE BEACH ZONING ORDINANCE,
AC HOTEL ORANGE BEACH PLANNED UNIT DEVELOPMENT
PRELIMINARY AND FINAL PUD APPROVAL
(#0903-PUD-25)**

FINDINGS:

1. The following proposed amendment to the City of Orange Beach Zoning Ordinance has been heard and considered by the Orange Beach Planning Commission in Public Session after the required public advertisement period.
2. The City Council of the City of Orange has held the required Public Hearing after the required public advertisement period concerning the proposed amendment.

NOW, THEREFORE, BE IT ORDAINED BY THE CITY COUNCIL OF THE CITY OF ORANGE BEACH, ALABAMA, AS FOLLOWS:

1. That the Zoning Ordinance of the City of Orange Beach as previously amended is hereby further amended for the property described;
2. That the zoning classification is hereby rezoned from RM-2 (Multi-Family Residential High Density) to PUD (Planned Unit Development) for the property legally described as follows:

103.7' X 800' FM INT OF W SEC LINE AND S R/W OF AL HWY 182 RUN
TH NE ALG SD R/W 2330'(S) TO POB, TH CONT ALG SD R/W 103.7', TH S
800' TO GULF OF MEXICO, TH SW'LY ALG GULF 103.7', TH N TO POB
SEC 13-T9S-R4E (WD)

*Tax Parcel ID #05-66-06-13-3-001-104.000, PPIN #3292
23370 Perdido Beach Boulevard*

3. That the Zoning Ordinance of the City of Orange Beach as previously amended is hereby further amended to approve the preliminary and final PUD for AC Hotel Orange Beach, converting an existing building into a hotel with 100 lodging rooms, pursuant to application #0903-PUD-25 on file with the Department of Community Development;
4. That approval of this PUD is contingent upon the conditions recommended by staff and Planning Commission as follows:
 - a. Providing concurrence from the Alabama Department of Transportation for improvements to the existing driveway on Perdido Beach Boulevard.
 - b. Providing sign details for the proposed freestanding sign in front of the parking structure.
 - c. The height of the buffer wall between this development and Beach Music may need to be increased near the location of the double stack parking system to alleviate any negative impacts on Beach Music.
 - d. All exterior lighting must be wildlife friendly per the City Code (See Chapter 30, Article XII, "Wildlife-friendly lighting").
5. That all ordinances or parts of ordinances in conflict are, to the extent of such conflict, repealed; and
6. That this Ordinance shall become effective immediately upon its adoption and publication as

required by law.

ADOPTED THIS 16th DAY OF DECEMBER, 2025.

Renee Eberly
City Clerk

The City Clerk of the City of Orange Beach, Alabama hereby certifies that the foregoing ORDINANCE 2025-xxxx

was posted on _____ in the following three

(3) public places:

Orange Beach City Hall _____

Orange Beach Post Office _____

Orange Beach Public Library _____

Renee Eberly, City Clerk



**REGULAR CITY COUNCIL MEETING
DECEMBER 16, 2025**

Departments: City Clerk

Description of Topic: First Reading - Ordinance adopting the Baldwin County Emergency Communications District GIS/Addressing Office street name standards within the City of Orange Beach, Alabama.

Background/Description:

Action Options/Recommendation:

Source of Funding (if applicable):

ATTACHMENTS:

1. 2025-xxxx Adopt Baldwin County 911 Addressing Standards

ORDINANCE NO. 2025-xxxx

**AN ORDINANCE ADOPTING THE BALDWIN COUNTY
EMERGENCY COMMUNICATION DISTRICT
GIS/ADDRESSING OFFICE STREET NAME STANDARDS
WITHIN THE CITY OF ORANGE BEACH, ALABAMA**

FINDINGS:

1. The City of Orange Beach possesses general police powers granted to Alabama municipalities pursuant to Ala. Code 11-45-1 and Ala. Const. Title 15, Chapter 70, which includes the authority to designate street names and building addresses within the City and its police jurisdiction.
2. The City and Baldwin County Emergency Communication District (hereinafter “BC 9-1-1”) have entered into an agreement authorized by City Council via Resolution No. 25-____ on December 2, 2025, appointing and delegating authority to BC 9-1-1 as the addressing authority for the City of Orange Beach, Alabama.
3. As a part of the above-referenced agreement, the City is required to adopt BC 9-1-1 street name standards in order to maintain a uniform system of building numbering for all service locations requiring an address.
4. The City Council has determined that adopting the BC 9-1-1 street name standards is in the best interest of the City of Orange Beach, Alabama.

NOW, THEREFORE, BE IT ORDAINED BY THE CITY COUNCIL OF THE CITY OF ORANGE BEACH, ALABAMA, AS FOLLOWS:

1. That the City of Orange Beach, Alabama, hereby adopts the Baldwin County Emergency Communication District Addressing Street Name Standards as they currently exist and as may be modified from time to time in the future;
2. That all ordinances or parts of ordinances in conflict are repealed to the extent of such conflict; and
3. That this Ordinance shall become effective immediately upon its adoption and publication as required by law.

ADOPTED THIS 16th DAY OF DECEMBER, 2025.

Renee Eberly
City Clerk

The City Clerk of the City of Orange Beach, Alabama hereby certifies that the foregoing ORDINANCE 2025-xxxx was posted on _____ in the following three (3) public places:
Orange Beach City Hall _____
Orange Beach Post Office _____
Orange Beach Public Library _____

Renee Eberly, City Clerk



**REGULAR CITY COUNCIL MEETING
DECEMBER 16, 2025**

Departments: City Clerk

Description of Topic: First Reading - Ordinance amending and restating Chapter 42, Article II, Division 2, Section 42-41 of the Code of Ordinances for the City of Orange Beach, Alabama, to update technical codes for land development.

Background/Description:

Action Options/Recommendation:

Source of Funding (if applicable):

ATTACHMENTS:

1. 2025-xxxx Amd Ch 42 Art I II Building Code Rewrite

ORDINANCE NO. 2025-xxx

**AN ORDINANCE AMENDING AND RESTATING
CHAPTER 42, ARTICLE II, DIVISION 2, SECTION 42-41 OF THE CODE OF ORDINANCES
FOR THE CITY OF ORANGE BEACH, ALABAMA
TO UPDATE TECHNICAL CODES FOR LAND DEVELOPMENT**

FINDINGS:

1. This ordinance of the City of Orange Beach, Alabama adopts technical codes regulating and governing the construction, alteration, repair, conditions and maintenance of all property, buildings and structures; by providing the standards for supplied utilities, systems and facilities and other physical things and conditions essential to ensure that structures are safe, sanitary and fit for occupation and use; and the condemnation of buildings and structures unfit for human occupancy and use and the demolition of such structures in the City of Orange Beach, Alabama; provides for the issuance of permits and collection of fees therefore.

NOW, THEREFORE, BE IT ORDAINED BY THE CITY COUNCIL OF THE CITY OF ORANGE BEACH, ALABAMA, AS FOLLOWS:

1. That Chapter 42, Article II, Divisions 2-5 of the Code of Ordinances for the City of Orange Beach is hereby amended as follows:

DIVISION 2. - TECHNICAL CODES

Sec. 42-41. - Technical codes.

Pursuant to Code of Ala. 1975, § 11-45-8(c), the following rules and regulations which have been printed as a code in book or pamphlet form, copies of which are on file in the offices of the building official, city clerk, and the City of Orange Beach Public Library, are hereby adopted as rules and regulations in, of and for the city with the additions, insertions, deletions and changes, if any, as prescribed.

- (a) The 2024 *International Building Code* including Appendix Chapters B, I, K and P as published by the International Code Council, be and is hereby adopted as the Building Code of the City of Orange Beach, in the State of Alabama and the following sections are hereby revised:

Section 101.1 Insert: City of Orange Beach, Alabama

Section 101.4.6 Insert: And the Alabama Energy Code.

Section 103.1 Insert: The City of Orange Beach Building Department.

Section 105.2 Delete item 1 under "Building" in its entirety

Section 105.2 Under item 2 under "Building", delete "not over 7 feet (2134mm) high"

Section 105.2 Delete item 9 under "Building" in its entirety

Section 105.2.1 Delete in its entirety and replace with: "Where equipment replacements and repairs must be performed in an emergency situation, the permit application shall be submitted and inspections scheduled within the next working business day to the Building Department.

Section 105.3.2 Insert: "There will be a \$50 charge for extensions granted for permit applications in accordance with Section 105.3.2"

Section 105.4 Delete "of this jurisdiction" and Insert: "or other relevant Local, State or Federal laws, rules or regulations, as determined by the Building Official."

Section 105.5 Insert: "A minimum of one inspection must be requested within this 180 day period."

Section 105.5 Insert: "There will be a \$100 charge for extensions to permits in accordance with Section 105.5."

Insert new Section 107.1.1 SUBCONTRACTORS. The applicant shall submit a list of all known subcontractors on a form provided by the jurisdiction at the time of application. Such list shall include the name, address and phone number of each subcontractor. The sub-contract amount shall also be specified on the list. The subcontractor list shall be updated periodically, but not less than prior to rough inspection; meter release inspection; and final inspection.

Section 107.2 Insert: "All construction documents shall be prepared by an architect or engineer registered in the state of Alabama and shall be signed and sealed as required by law."

Section 107.2.6 Insert: "All setbacks, easements and buffers are the direct responsibility of the builder or homeowner and not the responsibility of the building department or the City of Orange Beach, Alabama. Therefore, on all structures moved to or constructed upon any properties within the corporate limits of the City of Orange Beach, a spot survey prepared by an Alabama-licensed surveyor must be submitted to the building department upon completion of pile supports on the first level. For slab supported structures this shall be a "Form Board" or "As Staked" survey done prior to concrete placement. This survey shall account for the proposed outside dimensions of building(s), accounting for wall thickness, band placement, or pile cap and slab placement. Dimensions are required from all lot lines. The survey shall depict grade elevations and proposed elevations of the lowest finished floor. Assumed elevations may be used if construction does not require an elevation certificate. Further building construction shall cease until the requirements of this paragraph are met. If an elevation certificate is required in accordance with Article III, it will have to be verified and amended for finished construction."

Section 107.2.6.1 Delete section in its entirety and insert: "All commercial and residential structures constructed within the corporate limits of the City of Orange Beach shall have the finished floor elevation (FFE) of any enclosed space one foot above the average centerline of the nearest paved road or public street, or be in accordance with Article III FLOOD DAMAGE PREVENTION, and any revisions thereto, whichever is greater. The one-foot-above-centerline requirement may be adjusted or waived in writing by the Director of Community Development due to obvious or unusual site conditions that would make strict application of this section impractical."

Section 109.3 Insert: "For new construction, the valuation used to determine the applicable fees shall be calculated from the most current version of the Building Valuation Data published by the International Code Council."

Section 109.6 Insert: "The policy for applications and permits issued in accordance with this Code is as follows: Plans Review fees, Issuance fees, Data Processing fees and Penalties are non-refundable. Permits that expire in accordance with Section 105.5 prior to commencement of any work may, upon written request, be granted a refund for the permit fee less a \$100 administration fee; no refund will be given where work on the permit has commenced."

Section 111.3 Delete in its entirety.

Section 1108.6.2.2.1 Delete Exception.

Section 1609.3 Exceptions, Insert: "3. Prospective Owners purchasing a Unit designated during the design and review to be a Type A Unit may submit a signed statement indicating their desire to alter their Type A Unit to Type B standards. With consent of the developer, the Unit may be constructed or altered to Type B standards. If the sale of the subject property/Unit does not close, the designated Unit must be retrofitted or built to Type A standards prior to Developer/Owner again offering the Unit for sale to the public." A "prospective owner" for purposes herein is contemplated to be an independent third party purchaser and not an affiliate of the Developer/Owner. This exception may be withheld at the discretion of the Community Development Director or Building Official.

Section 1609.3 Insert: The ultimate design wind speed, V_{ult} as determined by the City of Orange Beach Alabama is as follows:

RISK CATEGORY I	RISK CATEGORY II	RISK CATEGORY III
145 MPH	160 MPH	174 MPH

Risk Category IV must provide design wind speed determination by calculation.

Section 1612.3 Insert: City of Orange Beach April 19, 2019.

Section 2902.2 Delete Exception 6.

- (b) The *2025 Coastal Construction Supplement* published by Smart Home America, Inc., is hereby adopted as an appendage to the International Building Code for design and construction of structures within the City of Orange Beach, in the State of Alabama.
- (c) The *2024 International Residential Code* including Appendix Chapters AA, BA,BF, as published by the International Code Council, be and is hereby adopted as the Residential Code of the City of Orange Beach, in the State of Alabama and the following sections are hereby revised:

The *2024 Coastal Construction Supplement* published by Smart Home America, Inc., and attached hereto is hereby adopted as an appendage to the International Residential Code for design and construction of structures within the City of Orange Beach, in the State of Alabama.

Section R101.1 Insert: City of Orange Beach, Alabama.

Section R103.1 Insert: The City of Orange Beach Building Department.

Section R105.2 Delete item 1 in its entirety.

Section R105.2 Under item 2, delete "not over 7 feet (2134mm) high".

Section R105.2 Under item 3, insert "or located adjacent to tidally influenced waters."

Section R105.2 Delete item 5 in its entirety.

Section R105.2 Delete item 7 in its entirety.

Section R105.2 Delete item 10 in its entirety.

Section R105.3 Insert new item: "8. SUBCONTRACTORS. The applicant shall submit a list of all known subcontractors on a form provided by the jurisdiction at the time of application. Such list shall include the name, address and phone number of each subcontractor. The sub-contract amount shall also be specified on the list. The subcontractor list shall be updated periodically, but not less than prior to rough inspection; meter release inspection; and final inspection."

Section R105.3.2 Insert: "There will be a \$50 charge for extensions granted for permit applications in accordance with Section R 105.3.2."

Section 105.4 Delete "of this jurisdiction" and insert: "or other relevant Local, State or Federal laws, rules or regulations, as determined by the Building Official."

Section R105.5 Insert: "A minimum of one inspection must be requested within this 180 day period."

Section R105.5 Insert: "There will be a \$100 charge for extensions to permits in accordance with Section R105.5."

Section R106.1 Insert: "Structural portions of construction documents shall be prepared by an architect or engineer registered in the state of Alabama and shall be signed and sealed as required by law."

EXCEPTION:

- 1) Additions of not more than 50% of the area under roof or 1000sf whichever is less, may be constructed in accordance with the most recent edition of ICC 600 STANDARD FOR RESIDENTIAL CONSTRUCTION IN HIGH WIND REGIONS without engineered drawings.
- 2) Accessory buildings not exceeding 1,000 sf may be constructed in accordance with ICC 600 STANDARD FOR RESIDENTIAL CONSTRUCTION IN HIGH WIND REGIONS without engineered drawings.

Section R106.1.4 Under item 2, insert: "All residential structures moved to or constructed within the corporate limits of the City of Orange Beach shall have the finished floor elevation (FFE) of any enclosed space one foot above the average centerline of the nearest paved or public street, or be in accordance with Article III FLOOD DAMAGE PREVENTION, and any revisions thereto, whichever is greater. The one-foot-above-centerline requirement may be adjusted or waived in writing by the City Engineer due to obvious or unusual site conditions that would make strict application of this section impractical."

Section R106.2 Insert: "All setbacks, easements and buffers are the direct responsibility of the builder or homeowner and not the responsibility of the building department or the City of Orange Beach, Alabama. Therefore, on all structures moved to or constructed upon any properties within the corporate limits of the City of Orange Beach, a spot survey prepared by an Alabama-licensed surveyor must be submitted to the building department upon completion of pile supports on the first level. For slab supported structures this shall be a "Form Board" or "As Staked" survey done prior to concrete placement. This survey shall account for the proposed outside dimensions of building(s), accounting for wall thickness, band placement, or pile cap and slab placement. Dimensions are required from all lot lines. The survey shall depict grade elevations and proposed elevations of the lowest finished floor. Assumed elevations may be used if construction does not require an elevation certificate. Further building construction shall cease until the requirements of this paragraph are met. If an elevation certificate is required in accordance with Article III it will have to be verified and amended for finished construction."

Section R108.3 Insert: "For new construction, the valuation used to determine the applicable fees shall be calculated from the most current version of the Building Valuation Data published by the International Code Council."

Section R108.5 Insert: "The policy for applications and permits issued in accordance with this Code is as follows: Plans Review fees, Issuance fees, Data Processing fees and Penalties are non-refundable. Permits that expire in accordance with Section 105.5 prior to commencement of any work may, upon written request be granted a refund for the permit fee less a \$100 administration fee; no refund will be given where work for which the permit was issued has commenced."

Section R108.5.1 REBATES. A rebate in accordance with this section shall be given to the applicant upon application and evidence of certification of one of the listed programs. All fees must be paid in full and a Certificate of Occupancy issued for the subject property in order for the applicant to be eligible for the rebates under this Section.

LEED Certification 15%

Developed by the U.S. Green Building Council (USGBC) LEED certification provides independent, third-party verification that a home was designed and built using strategies aimed at achieving high performance in key areas of human and environmental health, sustainable site development, water savings, energy efficiency, materials selection and indoor environmental quality.

FORTIFIED HOME GOLD Certification 25%

FORTIFIED GOLD requires development of a continuous load path from roof to foundation; chimneys must be adequately anchored; and windows and entry doors, even those that are protected from wind-borne debris, must meet wind design pressure requirements for the location.

Section R110.3 Delete in its entirety.

Section R202: Add Definition: AGGREGATE GROSS FLOOR AREA. The total floor area inside the building envelope, including the exterior walls, and excluding uninhabitable attic spaces and spaces enclosed by screening or louvered walls.

Table R301.2(1) Delete and insert:

- Ground Snow Load – 0
- Wind Design
 - o Speed (mph) – 160
 - o Topographic Effect – No
 - o Special Wind Region – No
 - o Windborne Debris Zone – Yes
- Seismic Design Category – A
- Subject to Damage From
 - o Weathering – Negligible
 - o Frost Line Depth – 12”
 - o Termite – Very Heavy
- Winter Design Temp. – 30°
- Ice Barrier Underlayment Required – No
- Flood Hazards – NFIP 1985, FIS April 19,2019, Community Number 015011
- Air Freezing Index – 33
- Mean Annual Temp. – 67.5
- Manual J Design Criteria
 - o Elevation – 23
 - o Latitude – 30.2688757
 - o Winter Heating – 29
 - o Summer Cooling – 93

Section R301.2.1.2 Delete the Exception in its entirety.

Table R301.2.1.2 Delete in its entirety.

Section R306.1 Insert: "with an aggregate gross floor area exceeding 5000sf or a building height in stories exceeding two. For the purposes of this Section, a structure constructed on piers, pilings, shear walls or columns where the distance between the lowest horizontal supporting member and any portion of the grade or slab below the first elevated floor is 70" or greater shall be considered a story."

- (d) The 2024 International Fire Code including Appendix Chapters A, B, C, D E, F, H, and I as published by the International Code Council, be and is hereby adopted as the Fire Code of the City

of Orange Beach, in the State of Alabama and the following sections are hereby revised:

Section 101.1 City of Orange Beach, Alabama and its Police and Planning Jurisdiction.

Section 110.4 (SPECIFY OFFENSE) Fire Code Violation

(AMOUNT) As outlined in §1-7 of the city code.

(NUMBER OF DAYS) As outlined in §1-7 of the city code.

Section 112.4 Delete in its entirety and replace with: "Failure to comply. It shall be unlawful and a violation of the city code for any person to continue work after having been served with a stop work order, except such work as the person is directed to perform to remove a violation or unsafe condition. Penalties shall be provided in §1-7 of the city code."

Section 307.1.1 Insert: "Prohibited Open Burning. Open burning is prohibited unless approved by the fire chief."

Section 307.1.2 Insert: "Burning of dangerous or hazardous materials. No permit shall be issued for the burning of organic or other debris from lot clearing activities, or the burning of any materials which may produce dangerous, noxious, or toxic fumes, smoke, odors, or which may be considered dangerous to the health and general welfare of the people of the city."

Section 307.4.3 Exception; Delete and Insert: "Portable outdoor fireplaces used at one- and two-family dwellings equipped with approved spark arrestors."

Section 308.1.6.1 Insert "Open-flame cooking devices. Charcoal burners and other open-flame cooking devices shall not be operated on balconies or within 10 feet of combustible construction."

Exceptions:

1. One and two family dwellings.
2. Where buildings, balconies, and decks are protected with an approved automatic sprinkler system.

Section 505.1 Insert: "Address Identification. New and existing buildings shall be provided with approved address identification. The address identification shall be legible and placed in a position that is visible from the street or road fronting the property. Address identification characters shall contrast with their background. Address numbers shall be arabic numbers or alphabetical letters. Numbers shall not be spelled out. Each character shall be not less than 4 inches (102 mm) high with a minimum stroke width of ½ inch (12.7 mm). Where required by the fire code official, address identification shall be provided in additional approved locations to facilitate emergency response. Where access is by means of a private road and the building cannot be viewed from the public way, a monument, pole or other sign or means shall be used to identify the structure. Address identification shall be maintained. Address and building numbers for commercial properties shall be as follows:

1. 50' or less setback from addressed street curb – 4"
2. 51' to 100' or less setback from addressed street curb – 6"
3. 101' - 150' setback from addressed street curb – 8"
4. 151' - 200' setback from addressed street curb – 10"
5. 201' or greater setback from addressed street curb – Permanent sign that is not more than 50' from the street curb"

Section 505.1.1 Insert: "Beach address Identification. New and existing buildings (excluding single family dwellings) located on the south side of State Highway 182 (Perdido Beach Boulevard) with

frontage on the Gulf of Mexico shall comply with the following requirements for identification signs:

1. All new and existing buildings (excluding single family residential) with dune walkovers or boardwalks in excess of one hundred (100) feet in length, an *minimum of eighteen (18) inch by twenty-four (24) inch and a maximum of twenty-four (24) by thirty-six (36) inch* sign shall be installed at the south end of the boardwalk or walkover and shall face southward. Such sign shall comply with the specifications in paragraph 2, below.
2. All new and existing buildings (excluding single family residential) without dune walkovers or boardwalks, or with dune walkovers or boardwalks less than one hundred (100) feet in length, one (1) eighteen (18) inch by twenty-four (24) inch to twenty-four (24) inch by thirty-six (36) inch sign with (3) inch high letters and the background shall be white. Signs shall be properly mounted and shall be placed north of the Construction Control Line (CCL) established by the Alabama Department of Environmental Management. The sign shall be no less or greater than four (4) feet above grade.
3. Signs shall be attached to posts with two (2) inch minimum stainless steel screws or bolts as applicable.
4. Content of sign: Name of establishment and its street address.
5. The sign shall be maintained in good condition at all times.”

Section 507.5.7 Insert: “A private service fire hydrant shall be banded with a durable, high visibility (reflective) fire hydrant collar that is 1.75" in width green with white letters.

Section 901.2.1.1 Insert: “All sprinkler and fire alarm design drawings submitted to the fire department for review shall abide by the Alabama State Board of Licensure for Professional Engineers and Land Surveyors' fire protection position statement. NICET certification does not replace the requirement for professional licensure. The designing of fire protection and detection systems is engineering and as such must be designed by or under the direct supervision of professional engineers qualified to design fire protection and detection systems. Only fire protection and detection designs that have been signed and sealed by a qualified Alabama licensed professional engineer shall be approved for construction.”

Section 901.2.1.2 Insert: “Contractor Qualification Requirements. Copies of applicable permits and Certifications as required shall be submitted to the Fire Marshall for review.

Restaurant Fixed Extinguishing Systems:

The qualifier must possess manufacturer certification (which restricts them to that manufacturer) and/or NAFED/ICC certification (which would allow them to be unrestricted and service, maintain, or install any system).

Sprinkler Systems:

Must possess a current sprinkler permit through the Alabama State Fire Marshal's Office and applicable NICET certification.

Fire Alarm Systems:

Must possess a fire alarm permit through the Alabama State Fire Marshal's Office and applicable NICET certification. Must possess a minimum of NICET II to perform technician work, or work under the direct supervision of a NICET II.

Portable Fire Extinguishers:

Current certificate of training on portable fire extinguishers in compliance with NFPA 10.”

Section 903.4.4 Insert: “Multi-Tenant Buildings. In multi-tenant buildings requiring automatic fire sprinkler systems, and where no fire alarm is required by Section 907, each tenant shall have at least one notification device (horn/strobe) to provide audible and visual notification upon activation of the listed sprinkler monitoring system.”

Section 905.4.3 Insert: “Pressure Regulating Devices. Where hose valve pressure regulating devices are installed on 2 1/2 in. (65 mm) outlets, they shall be field adjustable, capable of being adjusted through the full adjustment range by a 3/8 in. (12 mm) rod with a maximum required torque of 30 foot-pounds (41 nm) while flowing water. Field adjustment shall not require any hose valve disassembly.”

Section 905.6.3 Insert: “Pressure Regulating Devices. Where hose valve pressure regulating devices are installed on 2 1/2 in. (65 mm) outlets, they shall be field adjustable, capable of being adjusted through the full adjustment range by a 3/8 in. (12 mm) rod with a maximum required torque of 30 foot-pounds (41 nm) while flowing water. Field adjustment shall not require any hose valve disassembly.”

Section 912.6.1 Insert: “All above-ground piping exposed to the weather shall be insulated to protect from freezing.”

Section 913.5 Delete in its entirety and replace with: "Testing and maintenance. Fire pumps shall be inspected, tested and maintained in accordance with this section and NFPA 25. More specifically, a weekly test of electric fire pump assemblies shall be conducted without flowing water due to the susceptibility to lightning in our area. Records of inspection, testing and maintenance shall be maintained.”

Section 1103.5.1 Insert: “Occupancies shall have 2 years from the date of the adoption of this code to comply with the fire sprinkler installation requirements.”

Section 1103.5.3 Insert: “[December 31, 2028]”

- (e) The 2024 *International Mechanical Code* including Appendix Chapter A, as published by the International Code Council, be and is hereby adopted as the Mechanical Code of the City of Orange Beach, in the State of Alabama and the following sections are hereby revised:

Section 101.1 Insert: “City of Orange Beach, Alabama”

Section 108.2 Mechanical permit fees shall be in accordance with Section 42-3(C)4 of the Code of Ordinances.

Section 108.6 Delete in its entirety and replace with: The code official shall authorize the refunding of fees as follows:

1. The full amount of any fee paid hereunder that was erroneously paid or collected.
2. Not more than twenty five percent of the permit fee paid where work has not been done under a permit issued in accordance with this code.

The code official shall not authorize the refunding of any fee paid, except upon written application filed by the original permittee not later than 180 days after the date of fee payment.

Section 114.4 (SPECIFY OFFENSE) Code Violation

(AMOUNT) As outlined in §1-7 of the city code.

(NUMBER OF DAYS) As outlined in §1-7 of the city code.

Section 115.4 Insert: Any person who shall continue any work on the system after having been served with a stop work order, except such work as the person is direct to perform to remove a violation or unsafe condition, shall be liable for a fine of not less than fifty dollars or more than one hundred dollars.

- (f) The *2024 International Plumbing Code* including Appendix Chapters C & E, as published by the International Code Council, be and is hereby adopted as the Plumbing Code of the City of Orange Beach, in the State of Alabama and the following sections are hereby revised:

Section 101.1 Insert: "City of Orange Beach, Alabama"

Section 108.4 Delete in its entirety and replace with, "Any person who commences work on an installation before obtaining the necessary permits shall be subject to penalty fees in accordance with Section 42-3(C)10 of the Code of Ordinances."

Section 108.5 Insert: "Plumbing permit fees shall be in accordance with Section 42-3(C)6 of the Code of Ordinances."

Section 114.4 (SPECIFY OFFENSE) Code Violation

(AMOUNT) As outlined in §1-7 of the city code.

(NUMBER OF DAYS) As outlined in §1-7 of the city code.

Section 305.4.1 Delete in its entirety.

Section 403.2 Delete Exceptions 5 and 6.

Section 903.1.1 Insert: "Six (6)"

- (g) The *2024 International Existing Building Code*, as published by the International Code Council, be and is hereby adopted as the Existing Building Code of the City of Orange Beach, in the State of Alabama and the following sections are hereby revised:

Section 101.1 Insert: "The City of Orange Beach, Alabama"

Delete all Sections of Chapter 14 and Insert 1401.1 "All commercial or residential structures (including one and two family dwellings), relocated or moved, to be utilized in a different location must be in compliance with all currently adopted building, plumbing, electrical, mechanical, and gas codes and standards. Additionally, each of the four items shall be met.

1. The owner of the structure shall provide proof that the structure was permitted and constructed under the building code edition(s) referenced in Section 42-41 of this ordinance. For building, plumbing, mechanical, electrical and gas installations not permitted in accordance with the code edition(s) referenced in Section 42-41 of this Ordinance, the owner may agree to make all necessary improvements required in order for said installations to comply with this ordinance and any local codes or standards within 30 days from the date of issuance of the moving permit. An additional one-time extension of 30 days may be granted by the building official after payment of an additional moving fee.
2. The owner must submit a letter showing that the structure has been inspected by a licensed professional pest service to be free of termites.
3. The structure must be set on the permanent foundation within 30 days of being placed onto the lot or the associated moving permit becomes void.
4. Failure to complete improvements under this section will be subject to penalties as provided by law. Proof of compliance with this section will be accompanied by a Certificate of Completion issued by the building official upon successful final inspection.

EXCEPTION: These requirements shall not apply to structures relocated within a platted lot for the purpose of correcting nonconformity in regards to setbacks or elevation."

- (h) The *2024 International Fuel Gas Code*, as published by the International Code Council, be and is hereby adopted as the Fuel Gas Code of the City of Orange Beach, in the State of Alabama and the following sections are hereby revised:

Section 101.1 Insert: "City of Orange Beach, Alabama"

Section 105.1 Delete: "An Owner, Owners authorized agent" and Insert: "Licensed by the State of Alabama"

Section 108.2 Insert: "Gas permit fees shall be in accordance with Section 42-3(C)7 of the Code of Ordinances."

Section 108.4 Delete in its entirety and replace with, "Any person who commences work on an installation before obtaining the necessary permits shall be subject to penalty fees in accordance with Section 42-3(C)10 of the Code of Ordinances."

Section 108.6 Insert: "A refund of 50 percent if work has not commenced."

Section 113.4 (SPECIFY OFFENSE) Code Violation

(AMOUNT) As outlined in §1-7 of the city code.

(NUMBER OF DAYS) As outlined in §1-7 of the city code.

- (i) The 2024 *International Swimming Pool and Spa Code*, as published by the International Code Council, be and is hereby adopted as Swimming Pool and Spa Code of the City of Orange Beach in the State of Alabama and the following sections are hereby revised:

Section 101.1 Insert: "The City of Orange Beach, Alabama"

Section 105.1 Insert: "A separate permit is required for the pool barrier. The application shall be made at time of swimming pool application. The barrier shall be in accordance with section section 305 of this code. The application shall be reviewed for compliance before issuance."

Section 109.2 Insert: "Swimming Pool and Spa Permit fees shall be in accordance with Section 42-3 of the Code of Ordinances."

Section 113.4 (SPECIFY OFFENSE) Code Violation

(AMOUNT) As outlined in §1-7 of the city code.

(NUMBER OF DAYS) As outlined in §1-7 of the city code.

Section 322.2.2, "Illumination Intensity," Add exception:

Within the Beach Overlay District (hereafter referred to as the BOD) artificial lighting for outdoor pools, indoor pools and underwater lighting shall minimize the potential for negative effects to the nocturnal behaviors of nesting and hatching sea turtles and other wildlife. Outdoor pool lighting in the BOD shall provide an average of 3 foot-candles of illumination at the pool water surface and the pool wet deck surface and comply with the provisions of Section 321.2. For the purposes of this exception, the "Wet Deck Surface" shall mean the 4-foot wide (1219 mm) unobstructed pool deck area around the outside of the pool water perimeter, curb, ladders, handrails, diving boards, diving towers, pool slides, waterfalls, water features, starting blocks, planters, or lifeguard chairs. Other areas of the deck shall provide a minimum of 1 foot-candle of illumination. The pool deck light source shall be mounted as low to the ground or floor as practicable through the use of fixtures such as low-mounted wall fixtures, low bollards, and ground-level fixtures. Pole-mounted lights are not permitted for pool and pool deck lighting within the BOD. The light source shall be contained within a full cut-off or fully-shielded fixture such that no light is broadcast above a horizontal plane, and the point source of light and any reflective surfaces of the fixture are not directly visible from the beach. The lamps shall emit predominately long-wavelength light (> 580 nm). These long-wavelength light sources include low-pressure sodium vapor lamps, amber and red LEDs, true red neon lamps, and other lamps as permitted by the U.S. Fish and Wildlife Service regulations.

Indoor pool lighting within the BOD shall provide a minimum of 10 foot-candles of illumination at the pool water surface and wet deck surface and comply with Section 321.2. The glass in all exterior windows and glass doors shall be treated to achieve an industry-approved, inside-to-outside light transmittance value of 45 percent or less. Such transmittance is limited to the visible spectrum (400 to 700 nm wavelength) and is measured as the percentage of light that is transmitted through the glass.

All pool illumination in the BOD requires final approval from the U.S. Fish and Wildlife Service prior to the building(s) receiving a Certificate of Occupancy or the pool receiving a Certificate of Completion. Nothing in this article shall be construed to authorize, license or permit any lighting or other act or condition in violation of the federal Endangered Species Act. Artificial lighting not prohibited by this law which may be in violation of the federal Endangered Species Act may be reported to the United States Department of Interior, Fish and Wildlife Service, for resolution and enforcement under federal law. Lighting not meeting the provisions of this exception may be authorized at any time during a period of emergency.

- (j) The *2023 National Electrical Code (NFPA 70)*, as published by the National Fire Protection Association, be and is hereby adopted as the Electrical Code of the City of Orange Beach, in the State of Alabama and the following sections are hereby revised:

Article 210.8(A)(9) Insert: “The required GFCI protection for outlets below design flood elevation shall be located in the panel.”

Article 210.8(A)(13) Insert: "For structures located in a Special Flood Hazard Area, the required GFCI protection for these outlets shall be located in the panel.”

Article 210.8(B)(4) Insert: "Protection required by this section for outdoor receptacles at grade level and located within the Special Flood Hazard Area shall be located within the panel.”

Article 210.8(F)(3) Insert: "for plug and cord connected hoists, the required GFCI protection shall be located in the panel.”

Article 210.52(E) Insert: "for structures located in a Special Flood Hazard Area, the required GFCI protection for grade level outlets shall be located in the panel.”

Article 230.70(A)(1) Delete: “or inside nearest the point of entrance of the service conductors.”

- (k) For the purposes of regulating energy-efficient building envelopes and installation of energy-efficient mechanical, lighting and power systems in residential and commercial structures, the following codes are hereby adopted:

(1) Residential Structures—the Alabama Energy and Residential Codes including all amendments, as set forth in sections 305-2-4-.07, 305-2-4-.09, and 305-2-4-.10 of the Alabama Administrative Code.

(2) Commercial and Multi-Family Structures—the Alabama Energy and Residential Codes, including all amendments, as set forth in sections 305-2-4-.07 and 305-2-4-.08 of the Alabama Administrative Code.

- (l) The *2024 International Property Maintenance Code*, as published by the International Code Council, be and is hereby adopted as the Property Maintenance Code of the City of Orange Beach in the State of Alabama and the following sections are hereby revised:

Section 101.1 Insert: "The City of Orange Beach, Alabama”

Section 103.1 Insert: The Community Development Department is responsible for administration and enforcement of this code. The building official is hereby designated as the “code official” for the purposes of this code.

Section 104 Delete in its entirety.

Section 106 Delete in its entirety and Insert: Any person directly affected by a decision of the *code official* or a notice or order issued under this code shall have the right to appeal to the city council, provided that a written application for appeal is filed within 20 days after the day the decision, notice or order was served. An application for appeal shall be based on a claim that the true intent of this code or the rules legally adopted thereunder have been incorrectly interpreted, the provisions of this code do not fully apply, or the requirements of this code are adequately satisfied by other means.

Section 302.4, "Weeds," Insert: 12 inches

Section 304.14 Delete in its entirety.

Section 404 Delete in its entirety and Insert: Occupancy limitations shall be regulated by the International Building Code or International Residential Code.

Section 602.3 Insert: November 1st - February 28th

2. All ordinances, resolutions or parts in conflict with this ordinance, to the extent of such conflict, are repealed.
3. That this Ordinance shall become effective January 1, 2026.

ADOPTED THIS 16th DAY OF DECEMBER, 2025.

Renee Eberly
City Clerk

The City Clerk of the City of Orange Beach, Alabama hereby certifies that the foregoing ORDINANCE 2025-xxxx was posted on _____ in the following three (3) public places:
 Orange Beach City Hall _____
 Orange Beach Post Office _____
 Orange Beach Public Library _____

Renee Eberly, City Clerk



**REGULAR CITY COUNCIL MEETING
DECEMBER 16, 2025**

Departments: City Clerk

Description of Topic: First Reading - Ordinance amending Chapter 70, Article II, Section 70-22 of the Code of Ordinances for the City of Orange Beach, Alabama, to reduce the speed limit from 45 mph to 35 mph on the portion of State Highway 182 from Milepost 11.55 to Milepost 13.13.

Background/Description:

Action Options/Recommendation:

Source of Funding (if applicable):

ATTACHMENTS:

1. 2025-xxxx Amd Ch 70 Sec 70-22 Speed Limit Hwy 182

ORDINANCE NO. 2025-xxxx

**AN ORDINANCE AMENDING CHAPTER 70, ARTICLE II, SECTION 70-22
OF THE CODE OF ORDINANCES FOR THE CITY OF ORANGE BEACH, ALABAMA,
TO REDUCE THE SPEED LIMIT FROM 45 MPH TO 35 MPH ON THE PORTION OF
STATE HIGHWAY 182 FROM MILEPOST 11.55 TO MILEPOST 13.13**

FINDINGS:

1. Code of Alabama *When local authorities may and shall alter maximum limits* (Acts 1980, No. 80-434, p. 604, §8-104; Acts 1985, 2nd Ex. Sess., No. 85-998, p. 366, §2; Acts 1994, No.94-617, p. 1147, §2) authorizes state and/or local government authorities to decrease the speed limit at intersections or on any street, unpaved road, or highway under the jurisdiction and control of any city council.

NOW, THEREFORE, BE IT ORDAINED BY THE CITY COUNCIL OF THE CITY OF ORANGE BEACH, ALABAMA, AS FOLLOWS:

1. That Chapter 70, Article II, Section 70-22 of the Code of Ordinances for the City of Orange Beach is hereby amended and restated to read as follows:

Sec. 70-22. - Speed limits.

(a) *Definitions.* For the purposes of this chapter the following words or terms shall have the respective meanings ascribed to them:

- (1) *Business/Commercial Street*—Any street or road located in any part of the town zoned as business, commercial or industrial, whose speed limit shall be the same as a residential street.
- (2) *Collector Street/Thoroughfare Street*—Any street located in the designated Urban Zone of the town which serves as a primary conduit for vehicular traffic entering or leaving a particular subdivision or area, and on to which intersecting secondary streets or roads conduct vehicular traffic, or that serves as a primary conduit of traffic from one area of the town to another traversing a subdivision, subdivisions or areas, and for which an increased speed limit may be justified.
- (3) *Non-Standard Street*—Any public street located within the Urban Zone of the town, whose clear roadway width is less than 20 feet or whose surface condition, road course, character, or surrounding conditions are such that the speed limit generally set for residential or business streets might be too high for safe vehicle operation.
- (4) *Residential Street*—Any street or road located in any part of the town zoned as residential.
- (5) *Secondary Street*—Any residential or business/commercial street which does not serve as a collector or thoroughfare street for a subdivision or area, but primarily serves the residents or businesses on that particular street.
- (6) *Urban Zone*—That area of the town that is inclusive of the entire municipal limits.

(b) *Reasonable and prudent speed.* No person shall operate a vehicle at a speed greater than is reasonable and prudent under the existing conditions and having regard for actual, potential, or special hazards that may exist due to pedestrians, other traffic or by reason of weather or roadway conditions, regardless of the posted or authorized speed limit.

(c) *Maximum limits.* Except when one of the hazardous conditions as stated in subsection (2) exists, which requires a lower speed, the limits hereinafter specified or established shall be maximum lawful speeds, and no person shall operate a vehicle at a speed in excess of such maximum limits.

- (1) No person shall operate any vehicle on any business/commercial or residential street in the Urban Zone of the Town of Orange Beach at a speed greater than 25 miles per hour, except as provided herein.
- (2) No person shall operate any vehicle on:
 - a. State Highway 161 within the urban zone of the Town of Orange Beach at a speed greater than the speed limit posted by the state highway department, currently 45 miles per hour;
 - b. Canal Road within the urban zone of the City of Orange Beach at a speed greater than 28 miles per hour from the intersection of State Highway 161 eastward to Bay Circle; at a speed greater than 40 miles per hour from Bay Circle eastward to Wilson Boulevard; at a speed greater than 45 miles per hour from Wilson Boulevard eastward to the furthestmost eastern point of Canal Road; or as otherwise posted by the state highway department;
 - c. State Highway 180 within the urban zone of the City of Orange Beach at a speed greater than 40 miles per hour from the intersection of State Highway 161 westward to the intersection of Wharf Parkway West; at a speed greater than 50 miles per hour from the intersection of Wharf Parkway West westward to the city limit; or as otherwise posted by the state highway department;
 - d. State Highway 182 within the Urban Zone of the City of Orange Beach at a speed greater than 45 miles per hour, or as otherwise posted by the state highway department.
 1. No person shall operate a motor vehicle at a greater speed than 35 miles per hour on State Highway 182 from Milepost 16.80 to Milepost 17.08 (Florida line).
 2. No person shall operate a motor vehicle at a greater speed than 35 miles per hour on State Highway 182 from Milepost 11.55 to Milepost 13.13.
 - e. The following collector or thoroughfare streets at a speed greater than 35 miles per hour:
 1. Gulf Bay Road, north from Highway 180 to the 90 degree turn to the west.
 2. Marina Road, east from Highway 161 to the entrance to the Gulf State Park Boggy Point Boat Launch.
 - f. The following non-standard streets at a speed greater than 15 miles per hour:
 1. Dowty Lane;
 2. Illinois Street;
 3. Jubilee Point Road;
 4. Look Rook Road;
 5. Moses Road;
 6. Nana Brown Drive;
 7. Perdido Avenue West;
 8. Polaris Street;
 9. Tiger Brown Avenue.
 - g. The following residential streets at a speed greater than 20 miles per hour:
 1. Pine Boulevard;
 2. Pine Way;
 3. Caribe Drive;
 4. Lianna Court;

- 5. Lexmark Court;
- 6. Majestic Court.

- (d) *Establishment of speed zones.* Whenever the director of public safety and the director of public works of the City of Orange Beach, with the approval of the mayor, shall determine upon the basis of engineering or traffic investigations, that the speed limit of any street within the jurisdiction of the town should be altered in order to ensure the safety of its citizens or to facilitate the free flow of traffic, they shall present such as a recommendation to the town council who shall set the speed limit in accordance with the categories set out in this section.
- (e) *Posting of recommended speed limits.* The director of public works is hereby authorized to post recommended speed limits in conjunction with road hazard signs as recommended speeds for curves, hills, intersections, children at play, and other hazards that arise provided that such recommended speed limit posting be in accordance with the uniform traffic control and marking manual utilized by the state highway department. Such speed limits shall be strictly advisory in nature and shall not obligate the operator of a vehicle to reduce his speed below what is reasonable and prudent.
- (f) *Violation a misdemeanor.* Any person, firm or corporation violating the provisions of this section shall be guilty of a misdemeanor, and upon conviction may be fined not less than one dollar nor more than \$500.00, imprisoned in the municipal jail for a period of time not to exceed three months, or both pursuant to Ala. Code § 32-5A-8.

- 2. That all ordinances, resolutions or parts in conflict with this ordinance, to the extent of such conflict, are repealed; and
- 3. That this Ordinance shall become effective immediately upon its adoption and publication as required by law.

ADOPTED THIS 16th DAY OF DECEMBER, 2025.

 Renee Eberly
 City Clerk

The City Clerk of the City of Orange Beach, Alabama hereby certifies that the foregoing ORDINANCE 2025-xxxx was posted on _____ in the following three (3) public places:
 Orange Beach City Hall _____
 Orange Beach Post Office _____
 Orange Beach Public Library _____

 Renee Eberly, City Clerk